

STRESS ANALYSIS - PAGE 1



NEW MILLENNIUM
BUILDING SYSTEMS

Job Number: 8010-0704	Job Name: 10-123 BARRHAVEN FIRE STATION - SHOPORDERS	Date Run: 11/19/2010 3:56:45 PM
Location: OTTAWA, ON	Joist Description: Short Span Crimp 22K581/265	Mark: J01

Geometry

Base Length: 26-6 1/2	Working Length: 26-2 1/2	Joist Depth: 22.00	Effective Depth: 21.14	BC Panel Length: 6 @ 4-0	Shape: Parallel Chords
---------------------------------	------------------------------------	------------------------------	----------------------------------	------------------------------------	----------------------------------

Variable	Left End	Right End
BC Panel	1-10 1/4	1-10 1/4
TC Panel	1-7 5/8	1-7 5/8
First Half	1-5	1-5
First Diag.	3-3 1/4	3-3 1/4
Depth	22.00	22.00

Deflection Case 2a: LL (Max Deflection: -0.61 in-Y, -0.11 in-X)

Loads, *** All loads are factored ***

Load Type	Category	Load1	Load2	Position	Direction	Loc/Begin	Sp/End
Uniform (plf)	DL	183.50	183.50	TC	+	0-0	26-6 1/2
Uniform (plf)	LL	397.50	397.50	TC	+	0-0	26-6 1/2
Conc anywhere (lbs)	TL	315.00	0.00	BC	+	13-3 1/4	0-0
Uniform (plf)	TL	234.00	0.00	TC	+	0-0	6-10
Net Uplift (plf)	WL	197.00	197.00	TC	-	0-0	26-6 1/2
Conc anywhere (lbs)	TL	315.00	0.00	TC	+	13-3 1/4	0-0

Stress Analysis Summary

Int. Panel TC: 24.00	Max Panel BC: 48.00	Reaction LE: 8,988.84	Reaction RE: 8,311.39	Minimum Shear: 2,247.21	Max TC Comp.: 31,215.33	Max BC Tension: 30,281.79
--------------------------------	-------------------------------	---------------------------------	---------------------------------	-----------------------------------	-----------------------------------	-------------------------------------

Member	TC Tension	TC Compression	BC Tension	BC Compression	Web Tension	Web Comp.	Web Length	PP Dist.
W2	2,399.96	7,756.87	0.00	0.00	11,632.01	3,469.08	29.27	0-2
V1S	2,360.92	7,609.36	0.00	0.00	316.72	1,945.45	21.30	1-7 5/8
W3	2,360.92	7,609.36	13,165.98	4,122.90	2,811.31	9,162.29	27.12	1-10 1/4
W4	6,192.42	19,545.68	13,165.98	4,122.90	8,858.84	2,757.64	31.98	3-3 1/4
W5	6,192.42	19,545.68	24,456.32	7,802.04	2,144.83	6,955.39	31.98	5-3 1/4
W6	8,951.78	28,028.78	24,456.32	7,802.04	5,197.20	1,532.02	31.98	7-3 1/4
W7	8,951.78	28,028.78	30,281.79	9,641.62	1,003.79	3,400.19	31.98	9-3 1/4
W8	9,871.56	31,215.33	30,281.79	9,641.62	3,400.19	1,003.79	31.98	11-3 1/4

* Symmetrical Joist

Standard Verticals

Member	Position	Max Tension	Max Comp.	Length
V2	Interior	454.21	2,079.83	21.14

STRESS ANALYSIS - PAGE 2



Job Number: 8010-0704	Job Name: 10-123 BARRHAVEN FIRE STATION - SHOPORDERS	Date Run: 11/19/2010 3:56:45 PM
Location: OTTAWA, ON		Joist Description: Short Span Crimp 22K581/265
		Mark: J01

Chord Properties

Chord	Area	Rx	Rz	Ryy	Y	Ix	Q	Material
TC	0.4410	0.4610	0.2946	1.0962	0.4321	0.0937	1.0000	12 = 1 1/2 x 1 1/2 x .155
BC	0.4410	0.4610	0.2946	1.0962	0.4321	0.0937	1.0000	12 = 1 1/2 x 1 1/2 x .155

Axial and Bending Analysis

K: 1.00	Fy: 50,000.00	Fb: 45,000.00	Mom of Inertia: 197.18	LL 360: 409.21	LL 240: 613.82	Max Bridg TC: 13-3	Max Bridg BC: 11-8 5/8
-------------------	-------------------------	-------------------------	----------------------------------	--------------------------	--------------------------	------------------------------	----------------------------------

Top Chord Check	End Panel LE	First Panel LE	Interior Panel	First Panel RE	End Panel RE	
Length	17.63	19.63	24.00	19.63	17.63	Gap Between Chords: 1.1250
Bending Load	773.61	0.00	0.00	0.00	563.80	Min Weld Len 2X: 0.5000
Axial Load	7,756.87	7,609.36	31,215.33	7,146.20	7,258.20	Max Load Fillers TC: 31,906.69
fa	8,795.14	8,627.88	35,393.53	8,102.73	8,229.72	Max Load no Fillers TC: 24,023.39
Maximum K L/r	59.82	66.61	52.06	66.61	59.82	TC OAL/Ryy: 286.8947
Fcr	38,489.67	36,148.77	41,011.91	36,148.77	38,489.67	BC Stress: 42,311.34
Fa	34,640.70	32,533.90	36,910.72	32,533.90	34,640.70	BC L/Rz: 162.9103
F'e	195,823.59	157,944.30	105,608.96	157,944.30	195,823.59	TC Shear Stress: 18,630.03
Cm	0.9850	0.9818	0.8510	0.9829	0.9860	BC Shear Stress: 18,630.03
Panel Point Moment	2808.69	700.00	700.00	700.00	2228.06	
Mid Panel Moment	2150.86	590.63	590.63	590.63	1731.23	
Panel Point fb	16002.13	3988.15	3988.15	3988.15	12694.03	
Mid Panel fb	4957.88	1361.43	1361.43	1361.43	3990.60	
Fillers	0	0	6	0	0	
Panel Point Stress	24,797.27	12,616.03	39,381.68	12,090.88	20,923.75	
Mid Panel Stress	0.3554	0.2933	0.9954	0.2771	0.3191	

Web Design

Member	Web Tension	Allow Tension	Web Comp	Allow Comp	Weld	Qty	Material
W2	11,632.01	12,234.36	3,469.08	7,726.28	4.54 x 0.115	1	C18 = 1.125 x 1.012 x .115
W3	2,811.31	21,718.85	9,162.29	12,100.65	2.74 x 0.150	1	C28 = 1.125 x 1.347 x .150
W4	8,858.84	11,869.06	2,757.64	5,511.50	3.79 x 0.105	1	C16 = 1.125 x 0.943 x .105
W5	2,144.83	16,459.83	6,955.39	8,929.55	2.33 x 0.134	1	C22 = 1.125 x 1.086 x .134
W6	5,197.20	7,215.59	1,532.02	1,933.59	3.04 x 0.077	1	C10 = 1.125 x 0.700 x 0.07
W7	1,003.79	11,869.06	3,400.19	5,511.50	2.00 x 0.105	1	C16 = 1.125 x 0.943 x .105
W8	3,400.19	7,215.59	1,003.79	1,933.59	2.00 x 0.077	1	C10 = 1.125 x 0.700 x 0.07
V1	316.72	7,215.59	1,945.45	3,839.29	2.00 x 0.077	1	C10 = 1.125 x 0.700 x 0.07
V2	454.21	7,215.59	2,079.83	3,872.90	2.00 x 0.077	1	C10 = 1.125 x 0.700 x 0.07

* Symmetrical Joist

STRESS ANALYSIS - PAGE 3



NEW MILLENNIUM
BUILDING SYSTEMS

Job Number: 8010-0704	Job Name: 10-123 BARRHAVEN FIRE STATION - SHOPORDERS	Date Run: 11/19/2010 3:56:45 PM
Location: OTTAWA, ON	Joist Description: Short Span Crimp 22K581/265	Mark: J01

TCX Design

TCX Left		TCX Right	
TCX Length	0-0	TCX Length	0-1 1/2
TCX Type	R	TCX Type	R
TCX Depth	4	TCX Depth	4
BPL Length	0-4	BPL Length	0-11 1/4
Clear Bearing	0-4	Clear Bearing	0-6 1/2
BPL Material: 69L = 2 x 3 x .250		BPL Material: 27 = 2 1/2 x 2 1/2 x .250	
Total Load	581.00	Total Load	581.00
Reqd TL Def L/80	0.00	Reqd TL Def L/80	0.02
Live Load	397.50	Live Load	397.50
Reqd LL Def L/120	0.00	Reqd LL Def L/120	0.01
Section Modulus	0.0000	Section Modulus	0.1755
Reqd SM	0.0000	Reqd SM	0.0013
Mom of Inertia	0.0000	Mom of Inertia	0.1874
Reqd MI	0.0000	Reqd MI	0.0000
Seat Type: Lapped		Seat Type: Pegged or Butted	

LSD Design

- | | |
|--|--|
| Case 1a: DL | Case 6a: 1.25(DL)+0.5(CL+SL)+1.4(WL+AX)+0.8(TL) |
| Case 1b: 1.4(DL) | Case 6b: 1.25(DL)+0.5(CL+SL)+1.4(WL-AX)+0.8(TL) |
| Case 2a: LL | Case 6c: 1.25(DL)+0.5(CL+SL)+1.4(WL+AX+IP)+0.8(TL) |
| Case 2b: SL | Case 6d: 1.25(DL)+0.5(CL+SL)+1.4(WL-AX+IP)+0.8(TL) |
| Case 3a: 1.25(DL+CL)+1.5(TL+LL) | Case 7a: 1.25(DL+CL)+0.4(WL+AX)+1.5(TL+LL) |
| Case 3b: 1.25(DL+CL)+1.5(TL+SL) | Case 7b: 1.25(DL+CL)+0.4(WL-AX)+1.5(TL+LL) |
| Case 3c: 1.25(DL+CL)+1.5(TL+LL+FEM) | Case 7c: 1.25(DL+CL)+0.4(WL+AX+IP)+1.5(TL+LL) |
| Case 3d: 1.25(DL+CL)+1.5(TL+SL+FEM) | Case 7d: 1.25(DL+CL)+0.4(WL-AX+IP)+1.5(TL+LL) |
| Case 3e: DL+CL+TL+LL | Case 8a: 1.25(DL+CL)+0.4(WL+AX)+1.5(TL+SL) |
| Case 3f: DL+CL+TL+SL | Case 8b: 1.25(DL+CL)+0.4(WL-AX)+1.5(TL+SL) |
| Case 4a: 1.25(DL)+0.5(CL+LL)+1.4(WL+AX)+0.8(TL) | Case 8c: 1.25(DL+CL)+0.4(WL+AX+IP)+1.5(TL+SL) |
| Case 4b: 1.25(DL)+0.5(CL+LL)+1.4(WL-AX)+0.8(TL) | Case 8d: 1.25(DL+CL)+0.4(WL-AX+IP)+1.5(TL+SL) |
| Case 4c: 1.25(DL)+0.5(CL+LL)+1.4(WL+AX+IP)+0.8(TL) | Case 9a: DL+CL+0.5(LL)+0.7(TL)+SM+AX+FEM |
| Case 4d: 1.25(DL)+0.5(CL+LL)+1.4(WL-AX+IP)+0.8(TL) | Case 9b: DL+CL+0.5(LL)+0.7(TL)+SM-AX+FEM |
| Case 4e: 1.25(DL+CL)+1.4(WL+AX)+1.1(TL)+LL | Case 9c: DL+CL+0.25(SL)+0.7(TL)+SM+AX+FEM |
| Case 4f: 1.25(DL+CL)+1.4(WL-AX)+1.1(TL)+LL | Case 9d: DL+CL+0.25(SL)+0.7(TL)+SM-AX+FEM |
| Case 5a: 0.9(DL)+1.4(WL+AX) | Case 9e: DL+CL+LL+1.1(TL)+SM+AX+FEM |
| Case 5b: 0.9(DL)+1.4(WL-AX) | Case 9f: DL+CL+LL+1.1(TL)+SM-AX+FEM |
| Case 5c: 0.9(DL)+1.4(WL+AX+IP) | Case 10a: DL+SM+AX |
| Case 5d: 0.9(DL)+1.4(WL-AX+IP) | Case 10b: DL+SM-AX |
| Case 5e: DL+SM+AX | Case 10c: DL+CL+SM+AX |
| Case 5f: DL+SM-AX | Case 10d: DL+CL+SM-AX |

STRESS ANALYSIS - PAGE 1



NEW MILLENNIUM
BUILDING SYSTEMS

Job Number: 8010-0704	Job Name: 10-123 BARRHAVEN FIRE STATION - SHOPORDERS	Date Run: 11/19/2010 3:56:45 PM
Location: OTTAWA, ON	Joist Description: Short Span Crimp 22K626/289	Mark: J02

Geometry

Base Length: 26-6	Working Length: 26-2	Joist Depth: 22.00	Effective Depth: 21.08	BC Panel Length: 6 @ 4-0	Shape: Parallel Chords
-----------------------------	--------------------------------	------------------------------	----------------------------------	------------------------------------	----------------------------------

Variable	Left End	Right End	Deflection Case 2a: LL (Max Deflection: -0.63 in-Y, -0.11 in-X)
BC Panel	1-10	1-10	
TC Panel	1-7 1/2	1-7 1/2	
First Half	1-5	1-5	
First Diag.	3-3	3-3	
Depth	22.00	22.00	

Loads, *** All loads are factored ***

Load Type	Category	Load1	Load2	Position	Direction	Loc/Begin	Sp/End
Uniform (plf)	DL	192.50	192.50	TC	+	0-0	26-6
Uniform (plf)	LL	433.50	433.50	TC	+	0-0	26-6
Uniform (plf)	TL	234.00	0.00	TC	+	<0-0 1/4>	6-9 3/4
Conc anywhere (lbs)	TL	315.00	0.00	BC	+	13-3	0-0
Net Uplift (plf)	WL	197.00	197.00	TC	-	0-0	26-6
Conc anywhere (lbs)	TL	315.00	0.00	TC	+	13-3	0-0

Stress Analysis Summary

Int. Panel TC: 24.00	Max Panel BC: 48.00	Reaction LE: 9,563.37	Reaction RE: 8,887.72	Minimum Shear: 2,390.84	Max TC Comp.: 33,397.14	Max BC Tension: 32,409.42
--------------------------------	-------------------------------	---------------------------------	---------------------------------	-----------------------------------	-----------------------------------	-------------------------------------

Member	TC Tension	TC Compression	BC Tension	BC Compression	Web Tension	Web Comp.	Web Length	PP Dist.
W2	2,377.05	8,200.25	0.00	0.00	12,331.11	3,453.40	29.06	0-2
V1S	2,339.97	8,052.05	0.00	0.00	314.80	2,017.30	21.23	1-7 1/2
W3	2,339.97	8,052.05	14,014.54	4,108.32	2,816.76	9,794.25	27.08	1-10
W4	6,186.33	20,873.90	14,014.54	4,108.32	9,485.91	2,765.62	31.94	3-3
W5	6,186.33	20,873.90	26,157.21	7,802.56	2,151.04	7,443.11	31.94	5-3
W6	8,957.01	29,996.11	26,157.21	7,802.56	5,545.79	1,536.46	31.94	7-3
W7	8,957.01	29,996.11	32,409.42	9,649.68	1,005.10	3,623.15	31.94	9-3
W8	9,880.57	33,397.14	32,409.42	9,649.68	3,623.15	1,005.10	31.94	11-3

* Symmetrical Joist

Standard Verticals

Member	Position	Max Tension	Max Comp.	Length
V2	Interior	440.07	2,181.13	21.08

STRESS ANALYSIS - PAGE 2



NEW MILLENNIUM
BUILDING SYSTEMS

Job Number: 8010-0704	Job Name: 10-123 BARRHAVEN FIRE STATION - SHOPORDERS	Date Run: 11/19/2010 3:56:45 PM
Location: OTTAWA, ON	Joist Description: Short Span Crimp 22K626/289	Mark: J02

Chord Properties

Chord	Area	Rx	Rz	Ryy	Y	Ix	Q	Material
TC	0.4801	0.5431	0.3457	1.1847	0.4904	0.1416	0.9538	14 = 1 3/4 x 1 3/4 x .143
BC	0.4410	0.4610	0.2946	1.0962	0.4321	0.0937	1.0000	12 = 1 1/2 x 1 1/2 x .155

Axial and Bending Analysis

K: 1.00	Fy: 50,000.00	Fb: 45,000.00	Mom of Inertia: 204.46	LL 360: 426.34	LL 240: 639.51	Max Bridg TC: 14-3 3/4	Max Bridg BC: 11-8 5/8
-------------------	-------------------------	-------------------------	----------------------------------	--------------------------	--------------------------	----------------------------------	----------------------------------

Top Chord Check	End Panel LE	First Panel LE	Interior Panel	First Panel RE	End Panel RE	
Length	17.50	19.50	24.00	19.50	17.50	Gap Between Chords: 1.1250
Bending Load	816.84	0.00	0.00	0.00	606.93	Min Weld Len 2X: 0.5000
Axial Load	8,200.25	8,052.05	33,397.14	7,592.55	7,707.02	Max Load Fillers TC: 35,645.82
fa	8,541.02	8,386.67	34,785.00	7,908.07	8,027.29	Max Load no Fillers TC: 29,219.17
Maximum K L/r	50.62	56.40	44.19	56.40	50.62	TC OAL/Ryy: 265.0485
Fcr	39,886.32	38,200.70	41,618.54	38,200.70	39,886.32	BC Stress: 44,723.76
Fa	35,897.68	34,380.63	37,456.68	34,380.63	35,897.68	BC L/Rz: 162.9103
F'e	275,672.31	222,024.06	146,570.56	222,024.06	275,672.31	TC Shear Stress: 18,410.76
Cm	0.9897	0.9874	0.8945	0.9881	0.9903	BC Shear Stress: 19,829.40
Panel Point Moment	2886.33	700.00	700.00	700.00	2314.98	
Mid Panel Moment	2212.03	590.63	590.63	590.63	1797.59	
Panel Point fb	12838.13	3113.54	3113.54	3113.54	10296.84	
Mid Panel fb	3830.18	1022.68	1022.68	1022.68	3112.58	
Fillers	0	0	6	0	0	
Panel Point Stress	21,379.14	11,500.20	37,898.54	11,021.60	18,324.13	
Mid Panel Stress	0.3192	0.2658	0.9544	0.2518	0.2896	

Web Design

Member	Web Tension	Allow Tension	Web Comp	Allow Comp	Weld	Qty	Material
W2	12,331.11	14,813.85	3,453.40	9,685.86	4.13 x 0.134	1	C22 = 1.125 x 1.086 x .134
W3	2,816.76	21,718.85	9,794.25	12,174.00	2.93 x 0.150	1	C28 = 1.125 x 1.347 x .150
W4	9,485.91	11,869.06	2,765.62	5,602.66	4.06 x 0.105	1	C16 = 1.125 x 0.943 x .105
W5	2,151.04	16,459.83	7,443.11	8,999.35	2.49 x 0.134	1	C22 = 1.125 x 1.086 x .134
W6	5,545.79	7,215.59	1,536.46	1,979.32	3.25 x 0.077	1	C10 = 1.125 x 0.700 x 0.07
W7	1,005.10	11,869.06	3,623.15	5,602.66	2.00 x 0.105	1	C16 = 1.125 x 0.943 x .105
W8	3,623.15	7,215.59	1,005.10	1,979.32	2.12 x 0.077	1	C10 = 1.125 x 0.700 x 0.07
V1	314.80	7,215.59	2,017.30	3,900.23	2.00 x 0.077	1	C10 = 1.125 x 0.700 x 0.07
V2	440.07	7,215.59	2,181.13	3,930.54	2.00 x 0.077	1	C10 = 1.125 x 0.700 x 0.07

* Symmetrical Joist

STRESS ANALYSIS - PAGE 3



NEW MILLENNIUM
BUILDING SYSTEMS

Job Number: 8010-0704	Job Name: 10-123 BARRHAVEN FIRE STATION - SHOPORDERS	Date Run: 11/19/2010 3:56:45 PM
Location: OTTAWA, ON	Joist Description: Short Span Crimp 22K626/289	Mark: J02

TCX Design

TCX Left		TCX Right	
TCX Length	0-0 1/4	TCX Length	0-1 1/2
TCX Type	R	TCX Type	R
TCX Depth	4	TCX Depth	4
BPL Length	0-4 1/4	BPL Length	0-5 1/2
Clear Bearing	0-4 1/4	Clear Bearing	0-6 1/2
BPL Material: 69L = 2 x 3 x .250		BPL Material: 69L = 2 x 3 x .250	
Total Load	626.00	Total Load	626.00
Reqd TL Def L/80	0.00	Reqd TL Def L/80	0.02
Live Load	433.50	Live Load	433.50
Reqd LL Def L/120	0.00	Reqd LL Def L/120	0.01
Section Modulus	0.2248	Section Modulus	0.2248
Reqd SM	0.0000	Reqd SM	0.0014
Mom of Inertia	0.2832	Mom of Inertia	0.2832
Reqd MI	0.0000	Reqd MI	0.0000
Seat Type: Lapped		Seat Type: Lapped	

LSD Design

- | | |
|--|--|
| Case 1a: DL | Case 6a: 1.25(DL)+0.5(CL+SL)+1.4(WL+AX)+0.8(TL) |
| Case 1b: 1.4(DL) | Case 6b: 1.25(DL)+0.5(CL+SL)+1.4(WL-AX)+0.8(TL) |
| Case 2a: LL | Case 6c: 1.25(DL)+0.5(CL+SL)+1.4(WL+AX+IP)+0.8(TL) |
| Case 2b: SL | Case 6d: 1.25(DL)+0.5(CL+SL)+1.4(WL-AX+IP)+0.8(TL) |
| Case 3a: 1.25(DL+CL)+1.5(TL+LL) | Case 7a: 1.25(DL+CL)+0.4(WL+AX)+1.5(TL+LL) |
| Case 3b: 1.25(DL+CL)+1.5(TL+SL) | Case 7b: 1.25(DL+CL)+0.4(WL-AX)+1.5(TL+LL) |
| Case 3c: 1.25(DL+CL)+1.5(TL+LL+FEM) | Case 7c: 1.25(DL+CL)+0.4(WL+AX+IP)+1.5(TL+LL) |
| Case 3d: 1.25(DL+CL)+1.5(TL+SL+FEM) | Case 7d: 1.25(DL+CL)+0.4(WL-AX+IP)+1.5(TL+LL) |
| Case 3e: DL+CL+TL+LL | Case 8a: 1.25(DL+CL)+0.4(WL+AX)+1.5(TL+SL) |
| Case 3f: DL+CL+TL+SL | Case 8b: 1.25(DL+CL)+0.4(WL-AX)+1.5(TL+SL) |
| Case 4a: 1.25(DL)+0.5(CL+LL)+1.4(WL+AX)+0.8(TL) | Case 8c: 1.25(DL+CL)+0.4(WL+AX+IP)+1.5(TL+SL) |
| Case 4b: 1.25(DL)+0.5(CL+LL)+1.4(WL-AX)+0.8(TL) | Case 8d: 1.25(DL+CL)+0.4(WL-AX+IP)+1.5(TL+SL) |
| Case 4c: 1.25(DL)+0.5(CL+LL)+1.4(WL+AX+IP)+0.8(TL) | Case 9a: DL+CL+0.5(LL)+0.7(TL)+SM+AX+FEM |
| Case 4d: 1.25(DL)+0.5(CL+LL)+1.4(WL-AX+IP)+0.8(TL) | Case 9b: DL+CL+0.5(LL)+0.7(TL)+SM-AX+FEM |
| Case 4e: 1.25(DL+CL)+1.4(WL+AX)+1.1(TL)+LL | Case 9c: DL+CL+0.25(SL)+0.7(TL)+SM+AX+FEM |
| Case 4f: 1.25(DL+CL)+1.4(WL-AX)+1.1(TL)+LL | Case 9d: DL+CL+0.25(SL)+0.7(TL)+SM-AX+FEM |
| Case 5a: 0.9(DL)+1.4(WL+AX) | Case 9e: DL+CL+LL+1.1(TL)+SM+AX+FEM |
| Case 5b: 0.9(DL)+1.4(WL-AX) | Case 9f: DL+CL+LL+1.1(TL)+SM-AX+FEM |
| Case 5c: 0.9(DL)+1.4(WL+AX+IP) | Case 10a: DL+SM+AX |
| Case 5d: 0.9(DL)+1.4(WL-AX+IP) | Case 10b: DL+SM-AX |
| Case 5e: DL+SM+AX | Case 10c: DL+CL+SM+AX |
| Case 5f: DL+SM-AX | Case 10d: DL+CL+SM-AX |

STRESS ANALYSIS - PAGE 1



NEW MILLENNIUM
BUILDING SYSTEMS

Job Number: 8010-0704	Job Name: 10-123 BARRHAVEN FIRE STATION - SHOPORDERS	Date Run: 11/19/2010 3:56:46 PM
Location: OTTAWA, ON	Joist Description: Short Span Crimp 20K541/246	Mark: J04

Geometry

Base Length: 23-1 3/4	Working Length: 22-9 3/4	Joist Depth: 20.00	Effective Depth: 19.15	BC Panel Length: 5 @ 4-0	Shape: Parallel Chords
---------------------------------	------------------------------------	------------------------------	----------------------------------	------------------------------------	----------------------------------

Variable	Left End	Right End	Deflection Case 2a: LL (Max Deflection: -0.47 in-Y, -0.09 in-X)
BC Panel	1-8 5/8	1-8 5/8	
TC Panel	1-6 7/8	1-6 7/8	
First Half	1-10 1/4	1-10 1/4	
First Diag.	3-6 7/8	3-6 7/8	
Depth	20.00	20.00	

Loads, *** All loads are factored ***

Load Type	Category	Load1	Load2	Position	Direction	Loc/Begin	Sp/End
Uniform (plf)	DL	171.00	171.00	TC	+	0-0	23-1 3/4
Uniform (plf)	LL	369.00	369.00	TC	+	0-0	23-1 3/4
Uniform (plf)	TL	234.00	0.00	TC	+	<0-0 1/4>	6-9 3/4
Conc anywhere (lbs)	TL	315.00	0.00	BC	+	11-6 7/8	0-0
Net Uplift (plf)	WL	197.00	197.00	TC	-	0-0	23-1 3/4
Conc anywhere (lbs)	TL	315.00	0.00	TC	+	11-6 7/8	0-0

Stress Analysis Summary

Int. Panel TC: 24.00	Max Panel BC: 48.00	Reaction LE: 7,549.83	Reaction RE: 6,874.68	Minimum Shear: 1,887.46	Max TC Comp.: 23,965.07	Max BC Tension 24,723.57
--------------------------------	-------------------------------	---------------------------------	---------------------------------	-----------------------------------	-----------------------------------	------------------------------------

Member	TC Tension	TC Compression	BC Tension	BC Compression	Web Tension	Web Comp.	Web Length	PP Dist.
W2	2,103.96	6,527.76	0.00	0.00	9,783.11	3,017.78	26.71	0-2
V1S	2,072.50	6,414.95	0.00	0.00	345.69	1,943.49	19.23	1-6 7/8
W3	2,072.50	6,414.95	12,778.91	4,186.00	2,788.59	8,720.42	29.36	1-8 5/8
W4	5,959.12	17,973.24	12,778.91	4,186.00	7,062.84	2,268.47	30.70	3-6 7/8
W5	5,959.12	17,973.24	21,655.76	7,225.64	1,620.33	5,153.73	30.70	5-6 7/8
W6	7,985.55	23,965.07	21,655.76	7,225.64	3,422.21	972.20	30.70	7-6 7/8
W7	7,985.55	23,965.07	24,723.57	8,238.85	924.10	3,026.08	30.70	9-6 7/8

* Symmetrical Joist

Standard Verticals

Member	Position	Max Tension	Max Comp.	Length
V2	Interior	473.86	1,956.21	19.15

STRESS ANALYSIS - PAGE 2



NEW MILLENNIUM
BUILDING SYSTEMS

Job Number: 8010-0704	Job Name: 10-123 BARRHAVEN FIRE STATION - SHOPORDERS	Date Run: 11/19/2010 3:56:46 PM
Location: OTTAWA, ON		Joist Description: Short Span Crimp 20K541/246
		Mark: J04

Chord Properties

Chord	Area	Rx	Rz	Ryy	Y	Ix	Q	Material
TC	0.3731	0.4645	0.2959	1.0895	0.4230	0.0805	0.9759	09A = 1 1/2 x 1 1/2 x .130
BC	0.3922	0.4635	0.2955	1.0914	0.4256	0.0843	0.9945	10 = 1 1/2 x 1 1/2 x .137

Axial and Bending Analysis

K: 1.00	Fy: 50,000.00	Fb: 45,000.00	Mom of Inertia: 140.43	LL 360: 441.92	LL 240: 662.88	Max Bridg TC: 13-2	Max Bridg BC: 11-9
-------------------	-------------------------	-------------------------	----------------------------------	--------------------------	--------------------------	------------------------------	------------------------------

Top Chord Check	End Panel LE	First Panel LE	Interior Panel	First Panel RE	End Panel RE	Gap Between Chords: 1.1250
Length	16.88	24.00	24.00	24.00	16.88	Min Weld Len 2X: 0.5000
Bending Load	735.85	0.00	0.00	0.00	524.06	Max Load Fillers TC: 26,381.16
Axial Load	6,527.76	6,414.95	23,965.07	5,932.81	6,016.85	Max Load no Fillers TC: 20,029.01
fa	8,748.00	8,596.82	32,116.14	7,950.70	8,063.33	TC OAL/Ryy: 251.2661
Maximum K L/r	57.03	81.11	51.67	81.11	57.03	BC Stress: 40,442.55
Fcr	38,688.70	30,515.02	40,329.96	30,515.02	38,688.70	BC L/Rz: 162.4212
Fa	34,819.83	27,463.51	36,296.96	27,463.51	34,819.83	TC Shear Stress: 18,554.79
F'e	216,835.05	107,199.95	107,199.95	107,199.95	216,835.05	BC Shear Stress: 17,609.35
Cm	0.9866	0.9733	0.8668	0.9753	0.9876	
Panel Point Moment	3242.62	700.00	700.00	700.00	2493.37	
Mid Panel Moment	1653.07	590.63	590.63	590.63	1343.63	
Panel Point fb	21693.62	4683.10	4683.10	4683.10	16681.03	
Mid Panel fb	4343.83	1552.00	1552.00	1552.00	3530.69	
Fillers	0	0	4	0	0	
Panel Point Stress	30,441.62	13,279.93	36,799.25	12,633.81	24,744.36	
Mid Panel Stress	0.3420	0.3466	0.9256	0.3229	0.3052	

Web Design

Member	Web Tension	Allow Tension	Web Comp	Allow Comp	Weld	Qty	Material
W2	9,783.11	10,682.16	3,017.78	7,113.39	4.18 x 0.105	1	C16 = 1.125 x 0.943 x .105
W3	2,788.59	21,718.85	8,720.42	11,682.11	2.61 x 0.150	1	C28 = 1.125 x 1.347 x .150
W4	7,062.84	8,461.40	2,268.47	2,586.71	3.52 x 0.090	1	C12 = 1.125 x 0.715 x .090
W5	1,620.33	11,869.06	5,153.73	5,921.92	2.20 x 0.105	1	C16 = 1.125 x 0.943 x .105
W6	3,422.21	7,215.59	972.20	2,151.23	2.00 x 0.077	1	C10 = 1.125 x 0.700 x 0.07
W7	924.10	11,869.06	3,026.08	5,921.92	2.00 x 0.105	1	C16 = 1.125 x 0.943 x .105
V1	345.69	7,215.59	1,943.49	4,318.59	2.00 x 0.077	1	C10 = 1.125 x 0.700 x 0.07
V2	473.86	7,215.59	1,956.21	4,334.94	2.00 x 0.077	1	C10 = 1.125 x 0.700 x 0.07

* Symmetrical Joist

STRESS ANALYSIS - PAGE 3



NEW MILLENNIUM
BUILDING SYSTEMS

<i>Job Number:</i> 8010-0704	<i>Job Name:</i> 10-123 BARRHAVEN FIRE STATION - SHOPORDERS	<i>Date Run:</i> 11/19/2010 3:56:46 PM
<i>Location:</i> OTTAWA, ON	<i>Joist Description:</i> Short Span Crimp 20K541/246	<i>Mark:</i> J04

TCX Design

TCX Left		TCX Right	
TCX Length	0-0 1/4	TCX Length	0-0 1/2
TCX Type	R	TCX Type	R
TCX Depth	4	TCX Depth	4
BPL Length	0-4 1/4	BPL Length	0-10 1/4
Clear Bearing	0-4 3/8	Clear Bearing	0-5 5/8
BPL Material: 69L = 2 x 3 x .250		BPL Material: 27 = 2 1/2 x 2 1/2 x .250	
Total Load	540.00	Total Load	540.00
Reqd TL Def L/80	0.00	Reqd TL Def L/80	0.01
Live Load	369.00	Live Load	369.00
Reqd LL Def L/120	0.00	Reqd LL Def L/120	0.00
Section Modulus	0.1495	Section Modulus	0.1495
Reqd SM	0.0000	Reqd SM	0.0001
Mom of Inertia	0.1610	Mom of Inertia	0.1610
Reqd MI	0.0000	Reqd MI	0.0000
Seat Type: Lapped		Seat Type: Pegged or Butted	

LSD Design

- | | |
|--|--|
| Case 1a: DL | Case 6a: 1.25(DL)+0.5(CL+SL)+1.4(WL+AX)+0.8(TL) |
| Case 1b: 1.4(DL) | Case 6b: 1.25(DL)+0.5(CL+SL)+1.4(WL-AX)+0.8(TL) |
| Case 2a: LL | Case 6c: 1.25(DL)+0.5(CL+SL)+1.4(WL+AX+IP)+0.8(TL) |
| Case 2b: SL | Case 6d: 1.25(DL)+0.5(CL+SL)+1.4(WL-AX+IP)+0.8(TL) |
| Case 3a: 1.25(DL+CL)+1.5(TL+LL) | Case 7a: 1.25(DL+CL)+0.4(WL+AX)+1.5(TL+LL) |
| Case 3b: 1.25(DL+CL)+1.5(TL+SL) | Case 7b: 1.25(DL+CL)+0.4(WL-AX)+1.5(TL+LL) |
| Case 3c: 1.25(DL+CL)+1.5(TL+LL+FEM) | Case 7c: 1.25(DL+CL)+0.4(WL+AX+IP)+1.5(TL+LL) |
| Case 3d: 1.25(DL+CL)+1.5(TL+SL+FEM) | Case 7d: 1.25(DL+CL)+0.4(WL-AX+IP)+1.5(TL+LL) |
| Case 3e: DL+CL+TL+LL | Case 8a: 1.25(DL+CL)+0.4(WL+AX)+1.5(TL+SL) |
| Case 3f: DL+CL+TL+SL | Case 8b: 1.25(DL+CL)+0.4(WL-AX)+1.5(TL+SL) |
| Case 4a: 1.25(DL)+0.5(CL+LL)+1.4(WL+AX)+0.8(TL) | Case 8c: 1.25(DL+CL)+0.4(WL+AX+IP)+1.5(TL+SL) |
| Case 4b: 1.25(DL)+0.5(CL+LL)+1.4(WL-AX)+0.8(TL) | Case 8d: 1.25(DL+CL)+0.4(WL-AX+IP)+1.5(TL+SL) |
| Case 4c: 1.25(DL)+0.5(CL+LL)+1.4(WL+AX+IP)+0.8(TL) | Case 9a: DL+CL+0.5(LL)+0.7(TL)+SM+AX+FEM |
| Case 4d: 1.25(DL)+0.5(CL+LL)+1.4(WL-AX+IP)+0.8(TL) | Case 9b: DL+CL+0.5(LL)+0.7(TL)+SM-AX+FEM |
| Case 4e: 1.25(DL+CL)+1.4(WL+AX)+1.1(TL)+LL | Case 9c: DL+CL+0.25(SL)+0.7(TL)+SM+AX+FEM |
| Case 4f: 1.25(DL+CL)+1.4(WL-AX)+1.1(TL)+LL | Case 9d: DL+CL+0.25(SL)+0.7(TL)+SM-AX+FEM |
| Case 5a: 0.9(DL)+1.4(WL+AX) | Case 9e: DL+CL+LL+1.1(TL)+SM+AX+FEM |
| Case 5b: 0.9(DL)+1.4(WL-AX) | Case 9f: DL+CL+LL+1.1(TL)+SM-AX+FEM |
| Case 5c: 0.9(DL)+1.4(WL+AX+IP) | Case 10a: DL+SM+AX |
| Case 5d: 0.9(DL)+1.4(WL-AX+IP) | Case 10b: DL+SM-AX |
| Case 5e: DL+SM+AX | Case 10c: DL+CL+SM+AX |
| Case 5f: DL+SM-AX | Case 10d: DL+CL+SM-AX |

STRESS ANALYSIS - PAGE 1



NEW MILLENNIUM
BUILDING SYSTEMS

Job Number: 8010-0704	Job Name: 10-123 BARRHAVEN FIRE STATION - SHOPORDERS	Date Run: 11/19/2010 3:56:47 PM
Location: OTTAWA, ON	Joist Description: Short Span Crimp 20K616/281	Mark: J06

Geometry

Base Length: 22-11 3/4	Working Length: 22-7 3/4	Joist Depth: 20.00	Effective Depth: 19.15	BC Panel Length: 5 @ 4-0	Shape: Parallel Chords
----------------------------------	------------------------------------	------------------------------	----------------------------------	------------------------------------	----------------------------------

Variable	Left End	Right End	Deflection Case 2a: LL (Max Deflection: -0.50 in-Y, -0.09 in-X)
BC Panel	1-9 3/8	1-9 3/8	
TC Panel	1-8 7/8	1-8 7/8	
First Half	1-8 1/2	1-8 1/2	
First Diag.	3-5 7/8	3-5 7/8	
Depth	20.00	20.00	

Loads, *** All loads are factored ***

Load Type	Category	Load1	Load2	Position	Direction	Loc/Begin	Sp/End
Uniform (plf)	DL	193.50	193.50	TC	+	0-0	22-11 3/4
Uniform (plf)	LL	421.50	421.50	TC	+	0-0	22-11 3/4
Uniform (plf)	TL	234.00	0.00	TC	+	<0-2 1/2>	6-7 1/2
Conc anywhere (lbs)	TL	315.00	0.00	BC	+	11-5 7/8	0-0
Net Uplift (plf)	WL	197.00	197.00	TC	-	0-0	22-11 3/4
Conc anywhere (lbs)	TL	315.00	0.00	TC	+	11-5 7/8	0-0

Stress Analysis Summary

Int. Panel TC: 24.00	Max Panel BC: 48.00	Reaction LE: 8,345.51	Reaction RE: 7,677.46	Minimum Shear: 2,086.38	Max TC Comp.: 26,534.03	Max BC Tension 27,388.35
--------------------------------	-------------------------------	---------------------------------	---------------------------------	-----------------------------------	-----------------------------------	------------------------------------

Member	TC Tension	TC Compression	BC Tension	BC Compression	Web Tension	Web Comp.	Web Length	PP Dist.
W2	2,162.08	7,473.91	0.00	0.00	10,936.41	3,039.85	27.24	0-2
V1S	2,153.28	7,439.32	0.00	0.00	337.07	2,032.04	19.16	1-8 7/8
W3	2,153.28	7,439.32	13,929.01	4,080.17	2,636.77	9,188.15	28.05	1-9 3/8
W4	5,859.45	19,785.76	13,929.01	4,080.17	7,901.28	2,276.23	30.70	3-5 7/8
W5	5,859.45	19,785.76	23,940.71	7,130.37	1,625.88	5,760.76	30.70	5-5 7/8
W6	7,892.92	26,534.03	23,940.71	7,130.37	3,788.59	975.53	30.70	7-5 7/8
W7	7,892.92	26,534.03	27,388.35	8,147.10	920.48	3,345.27	30.70	9-5 7/8

* Symmetrical Joist

Standard Verticals

Member	Position	Max Tension	Max Comp.	Length
V2	Interior	438.50	2,120.49	19.15

STRESS ANALYSIS - PAGE 2



NEW MILLENNIUM
BUILDING SYSTEMS

Job Number: 8010-0704	Job Name: 10-123 BARRHAVEN FIRE STATION - SHOPORDERS	Date Run: 11/19/2010 3:56:47 PM
Location: OTTAWA, ON	Joist Description: Short Span Crimp 20K616/281	Mark: J06

Chord Properties

Chord	Area	Rx	Rz	Ryy	Y	Ix	Q	Material
TC	0.3922	0.4635	0.2955	1.0914	0.4256	0.0843	0.9945	10 = 1 1/2 x 1 1/2 x .137
BC	0.3922	0.4635	0.2955	1.0914	0.4256	0.0843	0.9945	10 = 1 1/2 x 1 1/2 x .137

Axial and Bending Analysis

K: 1.00	Fy: 50,000.00	Fb: 45,000.00	Mom of Inertia: 143.99	LL 360: 463.20	LL 240: 694.81	Max Bridg TC: 13-2 1/4	Max Bridg BC: 11-9 7/8
-------------------	-------------------------	-------------------------	----------------------------------	--------------------------	--------------------------	----------------------------------	----------------------------------

Top Chord Check	End Panel LE	First Panel LE	Interior Panel	First Panel RE	End Panel RE	Gap Between Chords: 1.1250
Length	18.88	21.00	24.00	21.00	18.88	Min Weld Len 2X: 0.5000
Bending Load	805.59	0.00	0.00	0.00	596.72	Max Load Fillers TC: 28,203.87
Axial Load	7,473.91	7,439.32	26,534.03	6,940.42	6,967.10	Max Load no Fillers TC: 21,290.23
fa	9,527.43	9,483.34	33,824.49	8,847.36	8,881.37	TC OAL/Ryy: 248.9999
Maximum K L/r	63.87	71.06	51.78	71.06	63.87	BC Stress: 43,839.49
Fcr	36,961.42	34,443.74	40,916.21	34,443.74	36,961.42	BC L/Rz: 162.4212
Fa	33,265.28	30,999.37	36,824.59	30,999.37	33,265.28	TC Shear Stress: 19,350.73
F'e	172,587.58	139,426.36	106,748.30	139,426.36	172,587.58	BC Shear Stress: 19,350.73
Cm	0.9816	0.9773	0.8592	0.9788	0.9828	
Panel Point Moment	3341.77	700.00	700.00	700.00	2660.75	
Mid Panel Moment	2466.93	590.63	590.63	590.63	1994.91	
Panel Point fb	21306.06	4462.97	4462.97	4462.97	16964.07	
Mid Panel fb	6229.54	1491.46	1491.46	1491.46	5037.59	
Fillers	0	0	4	0	0	
Panel Point Stress	30,833.50	13,946.31	38,287.47	13,310.33	25,845.44	
Mid Panel Stress	0.4158	0.3372	0.9578	0.3166	0.3713	

Web Design

Member	Web Tension	Allow Tension	Web Comp	Allow Comp	Weld	Qty	Material
W2	10,936.41	12,234.36	3,039.85	8,106.64	4.27 x 0.115	1	C18 = 1.125 x 1.012 x .115
W3	2,636.77	21,718.85	9,188.15	11,970.82	2.75 x 0.150	1	C28 = 1.125 x 1.347 x .150
W4	7,901.28	8,461.40	2,276.23	2,586.29	3.94 x 0.090	1	C12 = 1.125 x 0.715 x .090
W5	1,625.88	11,869.06	5,760.76	5,921.31	2.46 x 0.105	1	C16 = 1.125 x 0.943 x .105
W6	3,788.59	7,215.59	975.53	2,150.88	2.22 x 0.077	1	C10 = 1.125 x 0.700 x 0.07
W7	920.48	11,869.06	3,345.27	5,921.31	2.00 x 0.105	1	C16 = 1.125 x 0.943 x .105
V1	337.07	7,215.59	2,032.04	4,333.60	2.00 x 0.077	1	C10 = 1.125 x 0.700 x 0.07
V2	438.50	7,215.59	2,120.49	4,334.94	2.00 x 0.077	1	C10 = 1.125 x 0.700 x 0.07

* Symmetrical Joist

STRESS ANALYSIS - PAGE 3



NEW MILLENNIUM
BUILDING SYSTEMS

Job Number: 8010-0704	Job Name: 10-123 BARRHAVEN FIRE STATION - SHOPORDERS	Date Run: 11/19/2010 3:56:47 PM
Location: OTTAWA, ON	Joist Description: Short Span Crimp 20K616/281	Mark: J06

TCX Design

TCX Left		TCX Right	
TCX Length	0-2 1/2	TCX Length	0-0 1/4
TCX Type	R	TCX Type	R
TCX Depth	4	TCX Depth	4
BPL Length	0-6 1/2	BPL Length	0-10 1/4
Clear Bearing	0-6 5/8	Clear Bearing	0-5 1/2
BPL Material: 69L = 2 x 3 x .250		BPL Material: 27 = 2 1/2 x 2 1/2 x .250	
Total Load	615.00	Total Load	615.00
Reqd TL Def L/80	0.03	Reqd TL Def L/80	0.00
Live Load	421.50	Live Load	421.50
Reqd LL Def L/120	0.02	Reqd LL Def L/120	0.00
Section Modulus	0.1568	Section Modulus	0.1568
Reqd SM	0.0038	Reqd SM	0.0000
Mom of Inertia	0.1685	Mom of Inertia	0.1685
Reqd MI	0.0002	Reqd MI	0.0000
Seat Type: Lapped		Seat Type: Pegged or Butted	

LSD Design

- | | |
|--|--|
| Case 1a: DL | Case 6a: 1.25(DL)+0.5(CL+SL)+1.4(WL+AX)+0.8(TL) |
| Case 1b: 1.4(DL) | Case 6b: 1.25(DL)+0.5(CL+SL)+1.4(WL-AX)+0.8(TL) |
| Case 2a: LL | Case 6c: 1.25(DL)+0.5(CL+SL)+1.4(WL+AX+IP)+0.8(TL) |
| Case 2b: SL | Case 6d: 1.25(DL)+0.5(CL+SL)+1.4(WL-AX+IP)+0.8(TL) |
| Case 3a: 1.25(DL+CL)+1.5(TL+LL) | Case 7a: 1.25(DL+CL)+0.4(WL+AX)+1.5(TL+LL) |
| Case 3b: 1.25(DL+CL)+1.5(TL+SL) | Case 7b: 1.25(DL+CL)+0.4(WL-AX)+1.5(TL+LL) |
| Case 3c: 1.25(DL+CL)+1.5(TL+LL+FEM) | Case 7c: 1.25(DL+CL)+0.4(WL+AX+IP)+1.5(TL+LL) |
| Case 3d: 1.25(DL+CL)+1.5(TL+SL+FEM) | Case 7d: 1.25(DL+CL)+0.4(WL-AX+IP)+1.5(TL+LL) |
| Case 3e: DL+CL+TL+LL | Case 8a: 1.25(DL+CL)+0.4(WL+AX)+1.5(TL+SL) |
| Case 3f: DL+CL+TL+SL | Case 8b: 1.25(DL+CL)+0.4(WL-AX)+1.5(TL+SL) |
| Case 4a: 1.25(DL)+0.5(CL+LL)+1.4(WL+AX)+0.8(TL) | Case 8c: 1.25(DL+CL)+0.4(WL+AX+IP)+1.5(TL+SL) |
| Case 4b: 1.25(DL)+0.5(CL+LL)+1.4(WL-AX)+0.8(TL) | Case 8d: 1.25(DL+CL)+0.4(WL-AX+IP)+1.5(TL+SL) |
| Case 4c: 1.25(DL)+0.5(CL+LL)+1.4(WL+AX+IP)+0.8(TL) | Case 9a: DL+CL+0.5(LL)+0.7(TL)+SM+AX+FEM |
| Case 4d: 1.25(DL)+0.5(CL+LL)+1.4(WL-AX+IP)+0.8(TL) | Case 9b: DL+CL+0.5(LL)+0.7(TL)+SM-AX+FEM |
| Case 4e: 1.25(DL+CL)+1.4(WL+AX)+1.1(TL)+LL | Case 9c: DL+CL+0.25(SL)+0.7(TL)+SM+AX+FEM |
| Case 4f: 1.25(DL+CL)+1.4(WL-AX)+1.1(TL)+LL | Case 9d: DL+CL+0.25(SL)+0.7(TL)+SM-AX+FEM |
| Case 5a: 0.9(DL)+1.4(WL+AX) | Case 9e: DL+CL+LL+1.1(TL)+SM+AX+FEM |
| Case 5b: 0.9(DL)+1.4(WL-AX) | Case 9f: DL+CL+LL+1.1(TL)+SM-AX+FEM |
| Case 5c: 0.9(DL)+1.4(WL+AX+IP) | Case 10a: DL+SM+AX |
| Case 5d: 0.9(DL)+1.4(WL-AX+IP) | Case 10b: DL+SM-AX |
| Case 5e: DL+SM+AX | Case 10c: DL+CL+SM+AX |
| Case 5f: DL+SM-AX | Case 10d: DL+CL+SM-AX |

STRESS ANALYSIS - PAGE 1



NEW MILLENNIUM
BUILDING SYSTEMS

Job Number: 8010-0704	Job Name: 10-123 BARRHAVEN FIRE STATION - SHOPORDERS	Date Run: 11/19/2010 3:56:47 PM
Location: OTTAWA, ON	Joist Description: Short Span Crimp 20K616/281	Mark: J07

Geometry

Base Length: 22-11 3/4	Working Length: 22-7 3/4	Joist Depth: 20.00	Effective Depth: 19.00	BC Panel Length: 5 @ 4-0	Shape: Parallel Chords
----------------------------------	------------------------------------	------------------------------	----------------------------------	------------------------------------	----------------------------------

Variable	Left End	Right End	Deflection Case 2a: LL (Max Deflection: -0.43 in-Y, -0.06 in-X)
BC Panel	1-9 3/8	1-9 3/8	
TC Panel	1-8 7/8	1-8 7/8	
First Half	1-8 1/2	1-8 1/2	
First Diag.	3-5 7/8	3-5 7/8	
Depth	20.00	20.00	

Loads, *** All loads are factored ***

Load Type	Category	Load1	Load2	Position	Direction	Loc/Begin	Sp/End
Uniform (plf)	DL	193.50	193.50	TC	+	0-0	22-11 3/4
Uniform (plf)	LL	421.50	421.50	TC	+	0-0	22-11 3/4
Uniform (plf)	TL	234.00	0.00	TC	+	<0-2 1/2>	6-7 1/2
Axial (lbs)	WL	24,750.00	0.00	TC	+	0-0	0-0
Conc anywhere (lbs)	TL	315.00	0.00	BC	+	11-5 7/8	0-0
Net Uplift (plf)	WL	197.00	197.00	TC	-	0-0	22-11 3/4
Conc anywhere (lbs)	TL	315.00	0.00	TC	+	11-5 7/8	0-0

Stress Analysis Summary

Int. Panel TC: 24.00	Max Panel BC: 48.00	Reaction LE: 8,345.51	Reaction RE: 7,677.46	Minimum Shear: 2,086.38	Max TC Comp.: 45,284.31	Max BC Tension 27,605.37
--------------------------------	-------------------------------	---------------------------------	---------------------------------	-----------------------------------	-----------------------------------	------------------------------------

Member	TC Tension	TC Compression	BC Tension	BC Compression	Web Tension	Web Comp.	Web Length	PP Dist.
W2	26,929.21	30,526.81	0.00	0.00	10,980.33	3,052.06	27.14	0-2
V1S	26,920.34	30,500.22	0.00	0.00	337.07	2,125.80	19.00	1-8 7/8
W3	26,920.34	30,500.22	14,039.38	4,112.50	2,647.94	9,227.11	27.95	1-9 3/8
W4	30,655.88	40,058.88	14,039.38	4,112.50	7,939.60	2,287.26	30.61	3-5 7/8
W5	30,655.88	40,058.88	24,130.42	7,186.87	1,633.76	5,788.69	30.61	5-5 7/8
W6	32,705.46	45,284.31	24,130.42	7,186.87	3,806.96	980.26	30.61	7-5 7/8
W7	32,705.46	45,284.31	27,605.37	8,211.66	924.95	3,361.49	30.61	9-5 7/8

* Symmetrical Joist

Standard Verticals

Member	Position	Max Tension	Max Comp.	Length
V2	Interior	438.50	2,214.24	19.00

STRESS ANALYSIS - PAGE 2



NEW MILLENNIUM
BUILDING SYSTEMS

Job Number: 8010-0704	Job Name: 10-123 BARRHAVEN FIRE STATION - SHOPORDERS	Date Run: 11/19/2010 3:56:47 PM
Location: OTTAWA, ON	Joist Description: Short Span Crimp 20K616/281	Mark: J07

Chord Properties

Chord	Area	Rx	Rz	Ryy	Y	Ix	Q	Material
TC	0.6208	0.6001	0.3508	1.2870	0.5761	0.2235	1.0000	A34 = 1.9375 x .176
BC	0.3922	0.4635	0.2955	1.0914	0.4256	0.0843	0.9945	10 = 1 1/2 x 1 1/2 x .137

Axial and Bending Analysis

K: 1.00	Fy: 50,000.00	Fb: 45,000.00	Mom of Inertia: 173.82	LL 360: 559.15	LL 240: 838.73	Max Bridg TC: 15-6 5/8	Max Bridg BC: 11-9 1/4
-------------------	-------------------------	-------------------------	----------------------------------	--------------------------	--------------------------	----------------------------------	----------------------------------

Top Chord Check	End Panel LE	First Panel LE	Interior Panel	First Panel RE	End Panel RE	
Length	18.88	21.00	24.00	21.00	18.88	Gap Between Chords: 1.1250
Bending Load	805.59	0.00	0.00	0.00	596.72	Min Weld Len 2X: 0.5000
Axial Load	30,526.81	30,500.22	45,284.31	30,131.46	30,152.21	Max Load Fillers TC: 49,707.06
fa	24,587.85	24,566.43	36,474.29	24,269.41	24,286.12	Max Load no Fillers TC: 39,713.25
Maximum K L/r	53.80	59.86	40.00	59.86	53.80	TC OAL/Ryy: 211.1431
Fcr	40,463.59	38,477.39	44,480.71	38,477.39	40,463.59	BC Stress: 44,116.15
Fa	36,417.23	34,629.65	40,032.64	34,629.65	36,417.23	BC L/Rz: 162.4212
F'e	289,268.81	233,688.28	178,917.59	233,688.28	289,268.81	TC Shear Stress: 15,399.64
Cm	0.9717	0.9650	0.9094	0.9654	0.9720	BC Shear Stress: 19,360.84
Panel Point Moment	3341.77	700.00	700.00	700.00	2660.75	
Mid Panel Moment	2466.93	590.63	590.63	590.63	1994.91	
Panel Point fb	10177.08	2131.79	2131.79	2131.79	8103.08	
Mid Panel fb	3179.20	761.15	761.15	761.15	2570.90	
Fillers	0	0	8	0	0	
Panel Point Stress	34,764.93	26,698.22	38,606.08	26,401.20	32,389.21	
Mid Panel Stress	0.7426	0.7258	0.9288	0.7172	0.7213	

Web Design

Member	Web Tension	Allow Tension	Web Comp	Allow Comp	Weld	Qty	Material
W2	10,980.33	12,234.36	3,052.06	8,201.50	4.29 x 0.115	1	C18 = 1.125 x 1.012 x .115
W3	2,647.94	21,718.85	9,227.11	12,104.90	2.76 x 0.150	1	C28 = 1.125 x 1.347 x .150
W4	7,939.60	8,461.40	2,287.26	2,698.49	3.96 x 0.090	1	C12 = 1.125 x 0.715 x .090
W5	1,633.76	11,869.06	5,788.69	6,080.55	2.48 x 0.105	1	C16 = 1.125 x 0.943 x .105
W6	3,806.96	7,215.59	980.26	2,244.19	2.23 x 0.077	1	C10 = 1.125 x 0.700 x 0.07
W7	924.95	11,869.06	3,361.49	6,080.55	2.00 x 0.105	1	C16 = 1.125 x 0.943 x .105
V1	337.07	7,215.59	2,125.80	4,434.41	2.00 x 0.077	1	C10 = 1.125 x 0.700 x 0.07
V2	438.50	7,215.59	2,214.24	4,435.73	2.00 x 0.077	1	C10 = 1.125 x 0.700 x 0.07

* Symmetrical Joist

STRESS ANALYSIS - PAGE 3



NEW MILLENNIUM
BUILDING SYSTEMS

Job Number: 8010-0704	Job Name: 10-123 BARRHAVEN FIRE STATION - SHOPORDERS	Date Run: 11/19/2010 3:56:47 PM
Location: OTTAWA, ON	Joist Description: Short Span Crimp 20K616/281	Mark: J07

TCX Design

TCX Left		TCX Right	
TCX Length	0-2 1/2	TCX Length	0-0 1/4
TCX Type	R	TCX Type	R
TCX Depth	4	TCX Depth	4
BPL Length	0-6 1/2	BPL Length	0-4 1/4
Clear Bearing	0-6 5/8	Clear Bearing	0-5 1/2
BPL Material: 69L = 2 x 3 x .250		BPL Material: 69L = 2 x 3 x .250	

Total Load	615.00	Total Load	615.00
Reqd TL Def L/80	0.03	Reqd TL Def L/80	0.00
Live Load	421.50	Live Load	421.50
Reqd LL Def L/120	0.02	Reqd LL Def L/120	0.00
Section Modulus	0.3284	Section Modulus	0.3284
Reqd SM	0.0038	Reqd SM	0.0000
Mom of Inertia	0.4470	Mom of Inertia	0.4470
Reqd MI	0.0002	Reqd MI	0.0000

Seat Type: Lapped

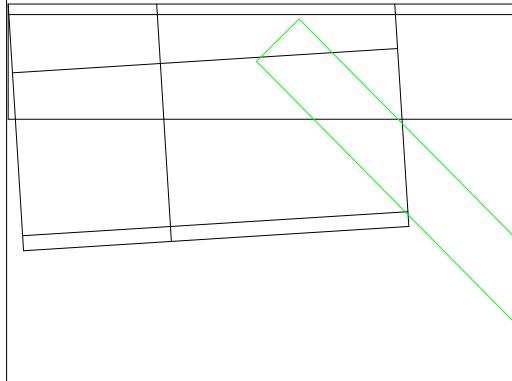

Seat Type: Lapped

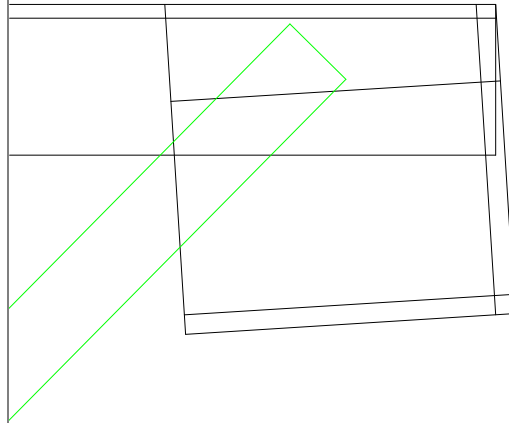

LSD Design

- | | |
|--|--|
| Case 1a: DL | Case 6a: 1.25(DL)+0.5(CL+SL)+1.4(WL+AX)+0.8(TL) |
| Case 1b: 1.4(DL) | Case 6b: 1.25(DL)+0.5(CL+SL)+1.4(WL-AX)+0.8(TL) |
| Case 2a: LL | Case 6c: 1.25(DL)+0.5(CL+SL)+1.4(WL+AX+IP)+0.8(TL) |
| Case 2b: SL | Case 6d: 1.25(DL)+0.5(CL+SL)+1.4(WL-AX+IP)+0.8(TL) |
| Case 3a: 1.25(DL+CL)+1.5(TL+LL) | Case 7a: 1.25(DL+CL)+0.4(WL+AX)+1.5(TL+LL) |
| Case 3b: 1.25(DL+CL)+1.5(TL+SL) | Case 7b: 1.25(DL+CL)+0.4(WL-AX)+1.5(TL+LL) |
| Case 3c: 1.25(DL+CL)+1.5(TL+LL+FEM) | Case 7c: 1.25(DL+CL)+0.4(WL+AX+IP)+1.5(TL+LL) |
| Case 3d: 1.25(DL+CL)+1.5(TL+SL+FEM) | Case 7d: 1.25(DL+CL)+0.4(WL-AX+IP)+1.5(TL+LL) |
| Case 3e: DL+CL+TL+LL | Case 8a: 1.25(DL+CL)+0.4(WL+AX)+1.5(TL+SL) |
| Case 3f: DL+CL+TL+SL | Case 8b: 1.25(DL+CL)+0.4(WL-AX)+1.5(TL+SL) |
| Case 4a: 1.25(DL)+0.5(CL+LL)+1.4(WL+AX)+0.8(TL) | Case 8c: 1.25(DL+CL)+0.4(WL+AX+IP)+1.5(TL+SL) |
| Case 4b: 1.25(DL)+0.5(CL+LL)+1.4(WL-AX)+0.8(TL) | Case 8d: 1.25(DL+CL)+0.4(WL-AX+IP)+1.5(TL+SL) |
| Case 4c: 1.25(DL)+0.5(CL+LL)+1.4(WL+AX+IP)+0.8(TL) | Case 9a: DL+CL+0.5(LL)+0.7(TL)+SM+AX+FEM |
| Case 4d: 1.25(DL)+0.5(CL+LL)+1.4(WL-AX+IP)+0.8(TL) | Case 9b: DL+CL+0.5(LL)+0.7(TL)+SM-AX+FEM |
| Case 4e: 1.25(DL+CL)+1.4(WL+AX)+1.1(TL)+LL | Case 9c: DL+CL+0.25(SL)+0.7(TL)+SM+AX+FEM |
| Case 4f: 1.25(DL+CL)+1.4(WL-AX)+1.1(TL)+LL | Case 9d: DL+CL+0.25(SL)+0.7(TL)+SM-AX+FEM |
| Case 5a: 0.9(DL)+1.4(WL+AX) | Case 9e: DL+CL+LL+1.1(TL)+SM+AX+FEM |
| Case 5b: 0.9(DL)+1.4(WL-AX) | Case 9f: DL+CL+LL+1.1(TL)+SM-AX+FEM |
| Case 5c: 0.9(DL)+1.4(WL+AX+IP) | Case 10a: DL+SM+AX |
| Case 5d: 0.9(DL)+1.4(WL-AX+IP) | Case 10b: DL+SM-AX |
| Case 5e: DL+SM+AX | Case 10c: DL+CL+SM+AX |
| Case 5f: DL+SM-AX | Case 10d: DL+CL+SM-AX |

STRESS ANALYSIS - PAGE 1



NEW MILLENNIUM
BUILDING SYSTEMS

Job Number: 8010-0704	Job Name: 10-123 BARRHAVEN FIRE STATION - SHOPORDERS	Date Run: 11/19/2010 3:56:48 PM
Location: OTTAWA, ON	Joist Description: Short Span Crimp 24K581/265	Mark: J09

Geometry

Base Length: 26-11 1/8	Working Length: 26-7 1/8	Joist Depth: 24.00	Effective Depth: 23.14	BC Panel Length: 6 @ 4-0	Shape: Parallel Chords
----------------------------------	------------------------------------	------------------------------	----------------------------------	------------------------------------	----------------------------------

Variable	Left End	Right End
BC Panel	2-0 5/8	2-0 5/8
TC Panel	1-8 3/4	1-8 3/4
First Half	1-5	1-4 7/8
First Diag.	3-5 5/8	3-5 1/2
Depth	24.00	24.00

Deflection Case 2a: LL (Max Deflection: -0.55 in-Y, -0.11 in-X)

Loads, *** All loads are factored ***

Load Type	Category	Load1	Load2	Position	Direction	Loc/Begin	Sp/End
Uniform (plf)	DL	183.50	183.50	TC	+	0-0	26-11 1/8
Uniform (plf)	LL	397.50	397.50	TC	+	0-0	26-11 1/8
Uniform (plf)	TL	234.00	0.00	TC	+	<0-2 1/4>	6-7 3/4
Conc anywhere (lbs)	TL	315.00	0.00	BC	+	13-5 5/8	0-0
Net Uplift (plf)	WL	197.00	197.00	TC	-	0-0	26-11 1/8
Conc anywhere (lbs)	TL	315.00	0.00	TC	+	13-5 5/8	0-0

Stress Analysis Summary

Int. Panel TC: 24.00	Max Panel BC: 48.00	Reaction LE: 9,121.00	Reaction RE: 8,426.48	Minimum Shear: 2,280.25	Max TC Comp.: 29,342.43	Max BC Tension: 28,497.19
--------------------------------	-------------------------------	---------------------------------	---------------------------------	-----------------------------------	-----------------------------------	-------------------------------------

Member	TC Tension	TC Compression	BC Tension	BC Compression	Web Tension	Web Comp.	Web Length	PP Dist.
W2	2,478.51	8,010.09	0.00	0.00	11,880.54	3,544.94	32.36	0-2
V1S	2,422.69	7,798.95	0.00	0.00	339.00	2,015.42	23.46	1-8 3/4
W3	2,422.69	7,798.95	12,891.32	4,039.15	2,730.22	8,880.39	28.71	2-0 5/8
W4	5,928.67	18,709.04	12,891.32	4,039.15	8,437.36	2,627.56	33.34	3-5 5/8
W5	5,928.67	18,709.04	23,188.38	7,398.06	2,044.00	6,634.62	33.34	5-5 5/8
W6	8,447.31	26,445.70	23,188.38	7,398.06	4,960.33	1,460.43	33.34	7-5 5/8
W7	8,447.31	26,445.70	28,497.19	9,076.42	969.95	3,285.54	33.34	9-5 5/8
W8	9,285.40	29,342.43	28,497.19	9,076.42	3,285.54	969.95	33.34	11-5 5/8

* Symmetrical Joist

Standard Verticals

Member	Position	Max Tension	Max Comp.	Length
V2	Interior	454.21	2,066.89	23.14

STRESS ANALYSIS - PAGE 2



NEW MILLENNIUM
BUILDING SYSTEMS

Job Number: 8010-0704	Job Name: 10-123 BARRHAVEN FIRE STATION - SHOPORDERS	Date Run: 11/19/2010 3:56:48 PM
Location: OTTAWA, ON	Joist Description: Short Span Crimp 24K581/265	Mark: J09

Chord Properties

Chord	Area	Rx	Rz	Ryy	Y	Ix	Q	Material
TC	0.4410	0.4610	0.2946	1.0962	0.4321	0.0937	1.0000	12 = 1 1/2 x 1 1/2 x .155
BC	0.4410	0.4610	0.2946	1.0962	0.4321	0.0937	1.0000	12 = 1 1/2 x 1 1/2 x .155

Axial and Bending Analysis

K: 1.00	Fy: 50,000.00	Fb: 45,000.00	Mom of Inertia: 236.23	LL 360: 469.24	LL 240: 703.85	Max Bridg TC: 13-3	Max Bridg BC: 12-1 1/2
-------------------	-------------------------	-------------------------	----------------------------------	--------------------------	--------------------------	------------------------------	----------------------------------

Top Chord Check	End Panel LE	First Panel LE	Interior Panel	First Panel RE	End Panel RE	
Length	18.75	20.88	24.00	20.75	18.75	Gap Between Chords: 1.1250
Bending Load	772.77	0.00	0.00	0.00	563.80	Min Weld Len 2X: 0.5000
Axial Load	8,010.09	7,798.95	29,342.43	7,334.14	7,494.30	Max Load Fillers TC: 31,906.69
fa	9,082.25	8,842.85	33,269.95	8,315.82	8,497.42	Max Load no Fillers TC: 24,023.39
Maximum K L/r	63.64	70.85	52.06	70.42	63.64	TC OAL/Ryy: 291.1137
Fcr	37,185.68	34,639.85	41,011.91	34,791.99	37,185.68	BC Stress: 40,287.88
Fa	33,467.12	31,175.87	36,910.72	31,312.79	33,467.12	BC L/Rz: 162.9103
F'e	173,029.73	139,595.14	105,608.96	141,282.08	173,029.73	TC Shear Stress: 18,864.05
Cm	0.9825	0.9789	0.8600	0.9804	0.9836	BC Shear Stress: 18,864.05
Panel Point Moment	3192.59	700.00	700.00	700.00	2509.02	
Mid Panel Moment	2367.05	590.63	590.63	590.63	1905.44	
Panel Point fb	18189.33	3988.15	3988.15	3988.15	14294.81	
Mid Panel fb	5456.22	1361.43	1361.43	1361.43	4392.17	
Fillers	0	0	6	0	0	
Panel Point Stress	27,271.58	12,831.00	37,258.10	12,303.97	22,792.23	
Mid Panel Stress	0.3838	0.3120	0.9369	0.2938	0.3442	

Web Design

Member	Web Tension	Allow Tension	Web Comp	Allow Comp	Weld	Qty	Material
W2	11,880.54	12,234.36	3,544.94	7,183.44	4.64 x 0.115	1	C18 = 1.125 x 1.012 x .115
W3	2,730.22	21,718.85	8,880.39	11,682.01	2.66 x 0.150	1	C28 = 1.125 x 1.347 x .150
W4	8,437.36	11,869.06	2,627.56	5,105.45	3.61 x 0.105	1	C16 = 1.125 x 0.943 x .105
W5	2,044.00	16,459.83	6,634.62	8,476.88	2.22 x 0.134	1	C22 = 1.125 x 1.086 x .134
W6	4,960.33	7,215.59	1,460.43	1,745.44	2.90 x 0.077	1	C10 = 1.125 x 0.700 x 0.07
W7	969.95	11,869.06	3,285.54	5,105.45	2.00 x 0.105	1	C16 = 1.125 x 0.943 x .105
W8	3,285.54	7,215.59	969.95	1,745.44	2.00 x 0.077	1	C10 = 1.125 x 0.700 x 0.07
V1	339.00	7,215.59	2,015.42	3,351.52	2.00 x 0.077	1	C10 = 1.125 x 0.700 x 0.07
V2	454.21	7,215.59	2,066.89	3,417.05	2.00 x 0.077	1	C10 = 1.125 x 0.700 x 0.07

* Symmetrical Joist

STRESS ANALYSIS - PAGE 3



NEW MILLENNIUM
BUILDING SYSTEMS

<i>Job Number:</i> 8010-0704	<i>Job Name:</i> 10-123 BARRHAVEN FIRE STATION - SHOPORDERS	<i>Date Run:</i> 11/19/2010 3:56:48 PM
<i>Location:</i> OTTAWA, ON	<i>Joist Description:</i> Short Span Crimp 24K581/265	<i>Mark:</i> J09

TCX Design

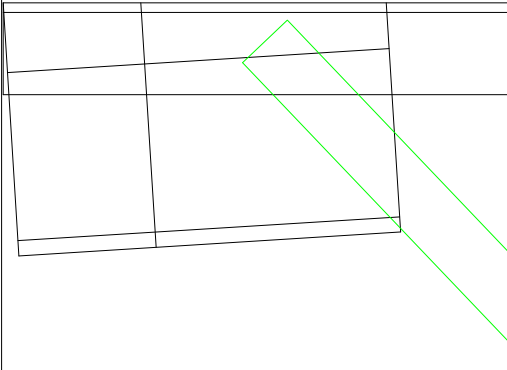
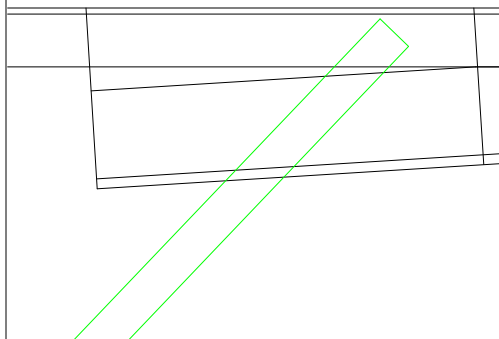
TCX Left		TCX Right	
TCX Length	0-2 1/4	TCX Length	0-0 3/4
TCX Type	R	TCX Type	R
TCX Depth	4	TCX Depth	4
BPL Length	0-6 1/4	BPL Length	0-10 5/8
Clear Bearing	0-6 1/4	Clear Bearing	0-5 7/8
BPL Material: 69L = 2 x 3 x .250		BPL Material: 27 = 2 1/2 x 2 1/2 x .250	
Total Load	581.00	Total Load	581.00
Reqd TL Def L/80	0.03	Reqd TL Def L/80	0.01
Live Load	397.50	Live Load	397.50
Reqd LL Def L/120	0.02	Reqd LL Def L/120	0.01
Section Modulus	0.1755	Section Modulus	0.1755
Reqd SM	0.0029	Reqd SM	0.0003
Mom of Inertia	0.1874	Mom of Inertia	0.1874
Reqd MI	0.0001	Reqd MI	0.0000
Seat Type: Lapped		Seat Type: Pegged or Butted	
			

LSD Design

- | | |
|--|---|
| <p>Case 1a: DL
 Case 1b: 1.4(DL)
 Case 2a: LL
 Case 2b: SL
 Case 3a: 1.25(DL+CL)+1.5(TL+LL)
 Case 3b: 1.25(DL+CL)+1.5(TL+SL)
 Case 3c: 1.25(DL+CL)+1.5(TL+LL+FEM)
 Case 3d: 1.25(DL+CL)+1.5(TL+SL+FEM)
 Case 3e: DL+CL+TL+LL
 Case 3f: DL+CL+TL+SL
 Case 4a: 1.25(DL)+0.5(CL+LL)+1.4(WL+AX)+0.8(TL)
 Case 4b: 1.25(DL)+0.5(CL+LL)+1.4(WL-AX)+0.8(TL)
 Case 4c: 1.25(DL)+0.5(CL+LL)+1.4(WL+AX+IP)+0.8(TL)
 Case 4d: 1.25(DL)+0.5(CL+LL)+1.4(WL-AX+IP)+0.8(TL)
 Case 4e: 1.25(DL+CL)+1.4(WL+AX)+1.1(TL)+LL
 Case 4f: 1.25(DL+CL)+1.4(WL-AX)+1.1(TL)+LL
 Case 5a: 0.9(DL)+1.4(WL+AX)
 Case 5b: 0.9(DL)+1.4(WL-AX)
 Case 5c: 0.9(DL)+1.4(WL+AX+IP)
 Case 5d: 0.9(DL)+1.4(WL-AX+IP)
 Case 5e: DL+SM+AX
 Case 5f: DL+SM-AX</p> | <p>Case 6a: 1.25(DL)+0.5(CL+SL)+1.4(WL+AX)+0.8(TL)
 Case 6b: 1.25(DL)+0.5(CL+SL)+1.4(WL-AX)+0.8(TL)
 Case 6c: 1.25(DL)+0.5(CL+SL)+1.4(WL+AX+IP)+0.8(TL)
 Case 6d: 1.25(DL)+0.5(CL+SL)+1.4(WL-AX+IP)+0.8(TL)
 Case 7a: 1.25(DL+CL)+0.4(WL+AX)+1.5(TL+LL)
 Case 7b: 1.25(DL+CL)+0.4(WL-AX)+1.5(TL+LL)
 Case 7c: 1.25(DL+CL)+0.4(WL+AX+IP)+1.5(TL+LL)
 Case 7d: 1.25(DL+CL)+0.4(WL-AX+IP)+1.5(TL+LL)
 Case 8a: 1.25(DL+CL)+0.4(WL+AX)+1.5(TL+SL)
 Case 8b: 1.25(DL+CL)+0.4(WL-AX)+1.5(TL+SL)
 Case 8c: 1.25(DL+CL)+0.4(WL+AX+IP)+1.5(TL+SL)
 Case 8d: 1.25(DL+CL)+0.4(WL-AX+IP)+1.5(TL+SL)
 Case 9a: DL+CL+0.5(LL)+0.7(TL)+SM+AX+FEM
 Case 9b: DL+CL+0.5(LL)+0.7(TL)+SM-AX+FEM
 Case 9c: DL+CL+0.25(SL)+0.7(TL)+SM+AX+FEM
 Case 9d: DL+CL+0.25(SL)+0.7(TL)+SM-AX+FEM
 Case 9e: DL+CL+LL+1.1(TL)+SM+AX+FEM
 Case 9f: DL+CL+LL+1.1(TL)+SM-AX+FEM
 Case 10a: DL+SM+AX
 Case 10b: DL+SM-AX
 Case 10c: DL+CL+SM+AX
 Case 10d: DL+CL+SM-AX</p> |
|--|---|

STRESS ANALYSIS - PAGE 1



NEW MILLENNIUM
BUILDING SYSTEMS

Job Number: 8010-0704	Job Name: 10-123 BARRHAVEN FIRE STATION - SHOPORDERS	Date Run: 11/19/2010 3:56:49 PM
Location: OTTAWA, ON	Joist Description: Short Span Crimp 24K581/265	Mark: J10

Geometry

Base Length: 26-11 1/8	Working Length: 26-7 1/8	Joist Depth: 24.00	Effective Depth: 23.01	BC Panel Length: 6 @ 4-0	Shape: Parallel Chords
----------------------------------	------------------------------------	------------------------------	----------------------------------	------------------------------------	----------------------------------

Variable	Left End	Right End
BC Panel	2-0 5/8	2-0 5/8
TC Panel	1-8 3/4	1-8 3/4
First Half	1-5	1-4 7/8
First Diag.	3-5 5/8	3-5 1/2
Depth	24.00	24.00

Deflection Case 2a: LL (Max Deflection: -0.59 in-Y, -0.11 in-X)

Loads, *** All loads are factored ***

Load Type	Category	Load1	Load2	Position	Direction	Loc/Begin	Sp/End
Uniform (plf)	DL	183.50	183.50	TC	+	0-0	26-11 1/8
Uniform (plf)	LL	397.50	397.50	TC	+	0-0	26-11 1/8
Conc anywhere (lbs)	TL	315.00	0.00	BC	+	13-5 5/8	0-0
Uniform (plf)	TL	140.00	140.00	TC	+	0-0	26-11 1/8
Net Uplift (plf)	WL	197.00	197.00	TC	-	0-0	26-11 1/8
Conc anywhere (lbs)	TL	315.00	0.00	TC	+	13-5 5/8	0-0

Stress Analysis Summary

Int. Panel TC: 24.00	Max Panel BC: 48.00	Reaction LE: 10,205.16	Reaction RE: 10,211.10	Minimum Shear: 2,552.78	Max TC Comp.: 35,416.57	Max BC Tension: 34,341.43
--------------------------------	-------------------------------	----------------------------------	----------------------------------	-----------------------------------	-----------------------------------	-------------------------------------

Member	TC Tension	TC Compression	BC Tension	BC Compression	Web Tension	Web Comp.	Web Length	PP Dist.
W2	2,491.54	9,180.55	0.00	0.00	13,529.00	3,554.06	32.27	0-2
V1S	2,435.42	8,980.76	0.00	0.00	339.05	1,977.11	23.34	1-8 3/4
W3	2,435.42	8,980.76	14,998.93	4,060.38	2,735.26	10,411.03	28.61	2-0 5/8
W4	5,959.83	22,090.24	14,998.93	4,060.38	10,170.71	2,634.73	33.25	3-5 5/8
W5	5,959.83	22,090.24	27,677.83	7,436.94	2,049.57	7,958.51	33.25	5-5 5/8
W6	8,491.71	31,761.70	27,677.83	7,436.94	5,875.12	1,464.42	33.25	7-5 5/8
W7	8,491.71	31,761.70	34,341.43	9,124.12	972.60	3,688.24	33.25	9-5 5/8
W8	9,334.19	35,416.57	34,341.43	9,124.12	3,688.24	972.60	33.25	11-5 5/8

* Symmetrical Joist

Standard Verticals

Member	Position	Max Tension	Max Comp.	Length
V2	Interior	405.01	2,249.08	23.01

STRESS ANALYSIS - PAGE 2



NEW MILLENNIUM
BUILDING SYSTEMS

Job Number: 8010-0704	Job Name: 10-123 BARRHAVEN FIRE STATION - SHOPORDERS	Date Run: 11/19/2010 3:56:49 PM
Location: OTTAWA, ON	Joist Description: Short Span Crimp 24K581/265	Mark: J10

Chord Properties

Chord	Area	Rx	Rz	Ryy	Y	Ix	Q	Material
TC	0.5185	0.5414	0.3450	1.1878	0.4947	0.1520	0.9837	15 = 1 3/4 x 1 3/4 x .155
BC	0.4801	0.5431	0.3457	1.1847	0.4904	0.1416	0.9538	14 = 1 3/4 x 1 3/4 x .143

Axial and Bending Analysis

K: 1.00	Fy: 50,000.00	Fb: 45,000.00	Mom of Inertia: 264.35	LL 360: 525.11	LL 240: 787.66	Max Bridg TC: 14-4 1/4	Max Bridg BC: 14-1 5/8
-------------------	-------------------------	-------------------------	----------------------------------	--------------------------	--------------------------	----------------------------------	----------------------------------

Top Chord Check	End Panel LE	First Panel LE	Interior Panel	First Panel RE	End Panel RE	
Length	18.75	20.88	24.00	20.75	18.75	Gap Between Chords: 1.1250
Bending Load	695.05	0.00	0.00	0.00	695.05	Min Weld Len 2X: 0.5000
Axial Load	9,180.55	8,980.13	35,416.57	8,980.76	9,180.55	Max Load Fillers TC: 39,595.66
fa	8,853.42	8,660.13	34,154.56	8,660.74	8,853.42	Max Load no Fillers TC: 32,238.33
Maximum K L/r	54.34	60.50	44.33	60.14	54.34	TC OAL/Ryy: 268.6697
Fcr	39,773.48	37,800.76	42,702.75	37,919.77	39,773.48	BC Stress: 41,995.60
Fa	35,796.14	34,020.68	38,432.47	34,127.80	35,796.14	BC L/Rz: 138.8426
F'e	238,648.23	192,534.16	145,659.31	194,860.83	238,648.23	TC Shear Stress: 18,362.60
Cm	0.9876	0.9850	0.8958	0.9852	0.9876	BC Shear Stress: 19,899.11
Panel Point Moment	2942.96	700.00	700.00	700.00	2927.74	
Mid Panel Moment	2193.58	590.63	590.63	590.63	2199.53	
Panel Point fb	12153.53	2890.78	2890.78	2890.78	12090.64	
Mid Panel fb	3570.25	961.30	961.30	961.30	3579.93	
Fillers	0	0	2	0	0	
Panel Point Stress	21,006.95	11,550.92	37,045.34	11,551.53	20,944.06	
Mid Panel Stress	0.3212	0.2746	0.9121	0.2738	0.3214	

Web Design

Member	Web Tension	Allow Tension	Web Comp	Allow Comp	Weld	Qty	Material
W2	13,529.00	14,813.85	3,554.06	9,052.52	4.53 x 0.134	1	C22 = 1.125 x 1.086 x .134
W3	2,735.26	21,718.85	10,411.03	11,825.54	3.12 x 0.150	1	C28 = 1.125 x 1.347 x .150
W4	10,170.71	11,869.06	2,634.73	5,276.27	4.35 x 0.105	1	C16 = 1.125 x 0.943 x .105
W5	2,049.57	16,459.83	7,958.51	8,694.75	2.67 x 0.134	1	C22 = 1.125 x 1.086 x .134
W6	5,875.12	7,215.59	1,464.42	1,821.67	3.44 x 0.077	1	C10 = 1.125 x 0.700 x 0.07
W7	972.60	11,869.06	3,688.24	5,276.27	2.00 x 0.105	1	C16 = 1.125 x 0.943 x .105
W8	3,688.24	7,215.59	972.60	1,821.67	2.16 x 0.077	1	C10 = 1.125 x 0.700 x 0.07
V1	339.05	7,215.59	1,977.11	3,464.64	2.00 x 0.077	1	C10 = 1.125 x 0.700 x 0.07
V2	405.01	7,215.59	2,249.08	3,529.86	2.00 x 0.077	1	C10 = 1.125 x 0.700 x 0.07

* Symmetrical Joist

STRESS ANALYSIS - PAGE 3



NEW MILLENNIUM
BUILDING SYSTEMS

Job Number: 8010-0704	Job Name: 10-123 BARRHAVEN FIRE STATION - SHOPORDERS	Date Run: 11/19/2010 3:56:49 PM
Location: OTTAWA, ON	Joist Description: Short Span Crimp 24K581/265	Mark: J10

TCX Design

TCX Left		TCX Right	
TCX Length	0-2 1/4	TCX Length	0-0 3/4
TCX Type	R	TCX Type	R
TCX Depth	4	TCX Depth	4
BPL Length	0-6 1/4	BPL Length	0-4 3/4
Clear Bearing	0-6 1/4	Clear Bearing	0-5 3/4
BPL Material: 69L = 2 x 3 x .250		BPL Material: 69L = 2 x 3 x .250	

Total Load	581.00	Total Load	581.00
Reqd TL Def L/80	0.03	Reqd TL Def L/80	0.01
Live Load	397.50	Live Load	397.50
Reqd LL Def L/120	0.02	Reqd LL Def L/120	0.01
Section Modulus	0.2421	Section Modulus	0.2421
Reqd SM	0.0029	Reqd SM	0.0003
Mom of Inertia	0.3040	Mom of Inertia	0.3040
Reqd MI	0.0001	Reqd MI	0.0000

Seat Type: Lapped

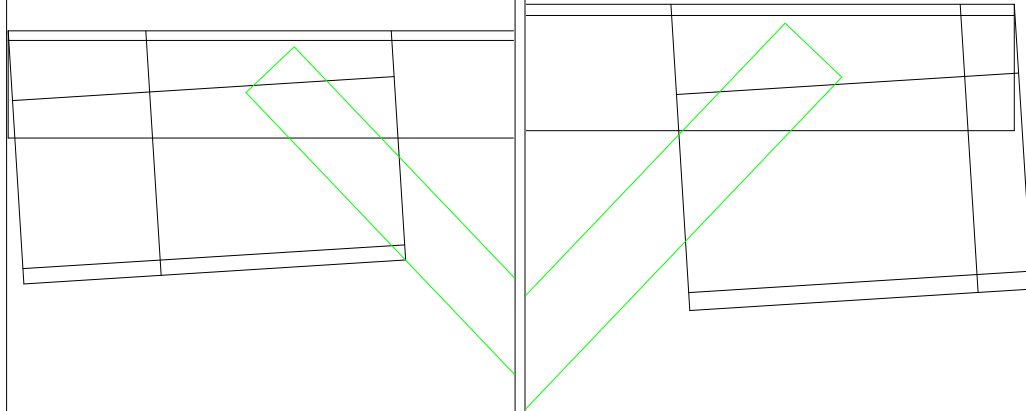

LSD Design

- | | |
|--|--|
| Case 1a: DL | Case 6a: 1.25(DL)+0.5(CL+SL)+1.4(WL+AX)+0.8(TL) |
| Case 1b: 1.4(DL) | Case 6b: 1.25(DL)+0.5(CL+SL)+1.4(WL-AX)+0.8(TL) |
| Case 2a: LL | Case 6c: 1.25(DL)+0.5(CL+SL)+1.4(WL+AX+IP)+0.8(TL) |
| Case 2b: SL | Case 6d: 1.25(DL)+0.5(CL+SL)+1.4(WL-AX+IP)+0.8(TL) |
| Case 3a: 1.25(DL+CL)+1.5(TL+LL) | Case 7a: 1.25(DL+CL)+0.4(WL+AX)+1.5(TL+LL) |
| Case 3b: 1.25(DL+CL)+1.5(TL+SL) | Case 7b: 1.25(DL+CL)+0.4(WL-AX)+1.5(TL+LL) |
| Case 3c: 1.25(DL+CL)+1.5(TL+LL+FEM) | Case 7c: 1.25(DL+CL)+0.4(WL+AX+IP)+1.5(TL+LL) |
| Case 3d: 1.25(DL+CL)+1.5(TL+SL+FEM) | Case 7d: 1.25(DL+CL)+0.4(WL-AX+IP)+1.5(TL+LL) |
| Case 3e: DL+CL+TL+LL | Case 8a: 1.25(DL+CL)+0.4(WL+AX)+1.5(TL+SL) |
| Case 3f: DL+CL+TL+SL | Case 8b: 1.25(DL+CL)+0.4(WL-AX)+1.5(TL+SL) |
| Case 4a: 1.25(DL)+0.5(CL+LL)+1.4(WL+AX)+0.8(TL) | Case 8c: 1.25(DL+CL)+0.4(WL+AX+IP)+1.5(TL+SL) |
| Case 4b: 1.25(DL)+0.5(CL+LL)+1.4(WL-AX)+0.8(TL) | Case 8d: 1.25(DL+CL)+0.4(WL-AX+IP)+1.5(TL+SL) |
| Case 4c: 1.25(DL)+0.5(CL+LL)+1.4(WL+AX+IP)+0.8(TL) | Case 9a: DL+CL+0.5(LL)+0.7(TL)+SM+AX+FEM |
| Case 4d: 1.25(DL)+0.5(CL+LL)+1.4(WL-AX+IP)+0.8(TL) | Case 9b: DL+CL+0.5(LL)+0.7(TL)+SM-AX+FEM |
| Case 4e: 1.25(DL+CL)+1.4(WL+AX)+1.1(TL)+LL | Case 9c: DL+CL+0.25(SL)+0.7(TL)+SM+AX+FEM |
| Case 4f: 1.25(DL+CL)+1.4(WL-AX)+1.1(TL)+LL | Case 9d: DL+CL+0.25(SL)+0.7(TL)+SM-AX+FEM |
| Case 5a: 0.9(DL)+1.4(WL+AX) | Case 9e: DL+CL+LL+1.1(TL)+SM+AX+FEM |
| Case 5b: 0.9(DL)+1.4(WL-AX) | Case 9f: DL+CL+LL+1.1(TL)+SM-AX+FEM |
| Case 5c: 0.9(DL)+1.4(WL+AX+IP) | Case 10a: DL+SM+AX |
| Case 5d: 0.9(DL)+1.4(WL-AX+IP) | Case 10b: DL+SM-AX |
| Case 5e: DL+SM+AX | Case 10c: DL+CL+SM+AX |
| Case 5f: DL+SM-AX | Case 10d: DL+CL+SM-AX |

STRESS ANALYSIS - PAGE 1



NEW MILLENNIUM
BUILDING SYSTEMS

Job Number: 8010-0704	Job Name: 10-123 BARRHAVEN FIRE STATION - SHOPORDERS	Date Run: 11/19/2010 3:56:50 PM
Location: OTTAWA, ON		Joist Description: Short Span Crimp 24K581/265
		Mark: J11

Geometry

Base Length: 26-11 1/8	Working Length: 26-7 1/8	Joist Depth: 24.00	Effective Depth: 23.16	BC Panel Length: 6 @ 4-0	Shape: Parallel Chords
----------------------------------	------------------------------------	------------------------------	----------------------------------	------------------------------------	----------------------------------

Variable	Left End	Right End
BC Panel	2-0 5/8	2-0 5/8
TC Panel	1-8 3/4	1-8 3/4
First Half	1-5	1-4 7/8
First Diag.	3-5 5/8	3-5 1/2
Depth	24.00	24.00

Deflection Case 2a: LL (Max Deflection: -0.66 in-Y, -0.12 in-X)

Loads, *** All loads are factored ***

Load Type	Category	Load1	Load2	Position	Direction	Loc/Begin	Sp/End
Uniform (plf)	DL	183.50	183.50	TC	+	0-0	26-11 1/8
Uniform (plf)	LL	397.50	397.50	TC	+	0-0	26-11 1/8
Net Uplift (plf)	WL	197.00	197.00	TC	-	0-0	26-11 1/8

Stress Analysis Summary

Int. Panel TC: 24.00	Max Panel BC: 48.00	Reaction LE: 7,725.48	Reaction RE: 7,725.48	Minimum Shear: 1,931.37	Max TC Comp.: 26,613.29	Max BC Tension: 26,014.34
--------------------------------	-------------------------------	---------------------------------	---------------------------------	-----------------------------------	-----------------------------------	-------------------------------------

Member	TC Tension	TC Compression	BC Tension	BC Compression	Web Tension	Web Comp.	Web Length	PP Dist.
W2	2,475.99	7,103.78	0.00	0.00	10,165.60	3,543.18	32.38	0-2
V1S	2,420.23	6,943.78	0.00	0.00	338.99	1,105.66	23.48	1-8 3/4
W3	2,420.23	6,943.78	11,576.79	4,035.04	2,729.24	7,830.38	28.73	2-0 5/8
W4	5,922.64	16,992.44	11,576.79	4,035.04	7,534.67	2,626.18	33.35	3-5 5/8
W5	5,922.64	16,992.44	21,203.91	7,390.53	2,042.92	5,861.27	33.35	5-5 5/8
W6	8,438.71	24,211.21	21,203.91	7,390.53	4,187.87	1,459.66	33.35	7-5 5/8
W7	8,438.71	24,211.21	26,014.34	9,067.18	969.44	2,781.38	33.35	9-5 5/8
W8	9,275.95	26,613.29	26,014.34	9,067.18	2,781.38	969.44	33.35	11-5 5/8

* Symmetrical Joist

Standard Verticals

Member	Position	Max Tension	Max Comp.	Length
V2	Interior	405.01	1,295.07	23.16

STRESS ANALYSIS - PAGE 2



NEW MILLENNIUM
BUILDING SYSTEMS

Job Number: 8010-0704	Job Name: 10-123 BARRHAVEN FIRE STATION - SHOPORDERS	Date Run: 11/19/2010 3:56:50 PM
Location: OTTAWA, ON		Joist Description: Short Span Crimp 24K581/265
		Mark: J11

Chord Properties

Chord	Area	Rx	Rz	Ryy	Y	Ix	Q	Material
TC	0.3731	0.4645	0.2959	1.0895	0.4230	0.0805	0.9759	09A = 1 1/2 x 1 1/2 x .130
BC	0.3318	0.4666	0.2968	1.0855	0.4176	0.0722	0.9284	08 = 1 1/2 x 1 1/2 x .115

Axial and Bending Analysis

K: 1.00	Fy: 50,000.00	Fb: 45,000.00	Mom of Inertia: 188.54	LL 360: 374.50	LL 240: 561.76	Max Bridg TC: 13-2	Max Bridg BC: 11-8 1/4
-------------------	-------------------------	-------------------------	----------------------------------	--------------------------	--------------------------	------------------------------	----------------------------------

Top Chord Check	End Panel LE	First Panel LE	Interior Panel	First Panel RE	End Panel RE	
Length	18.75	20.88	24.00	20.75	18.75	Gap Between Chords: 1.1250
Bending Load	563.80	0.00	0.00	0.00	563.80	Min Weld Len 2X: 0.5000
Axial Load	7,103.78	6,943.28	26,613.29	6,943.78	7,103.78	Max Load Fillers TC: 27,355.64
fa	9,519.94	9,304.85	35,665.09	9,305.52	9,519.94	Max Load no Fillers TC: 20,698.21
Maximum K L/r	63.36	70.55	51.67	70.12	63.36	TC OAL/Ryy: 292.9143
Fcr	36,639.04	34,209.27	40,329.96	34,354.63	36,639.04	BC Stress: 39,204.79
Fa	32,975.14	30,788.34	36,296.96	30,919.17	32,975.14	BC L/Rz: 161.7370
F'e	175,636.39	141,698.11	107,199.95	143,410.47	175,636.39	TC Shear Stress: 19,243.08
Cm	0.9819	0.9781	0.8521	0.9784	0.9819	BC Shear Stress: 21,746.14
Panel Point Moment	1810.98	0.00	0.00	0.00	1798.63	
Mid Panel Moment	1258.49	0.00	0.00	0.00	1263.32	
Panel Point fb	12115.74	0.00	0.00	0.00	12033.10	
Mid Panel fb	3306.97	0.00	0.00	0.00	3319.65	
Fillers	0	0	6	0	0	
Panel Point Stress	21,635.68	9,304.85	35,665.09	9,305.52	21,553.04	
Mid Panel Stress	0.3586	0.3022	0.9826	0.3010	0.3589	

Web Design

Member	Web Tension	Allow Tension	Web Comp	Allow Comp	Weld	Qty	Material
W2	10,165.60	10,682.16	3,543.18	6,237.04	4.35 x 0.105	1	C16 = 1.125 x 0.943 x .105
W3	2,729.24	16,459.83	7,830.38	8,137.70	2.62 x 0.134	1	C22 = 1.125 x 1.086 x .134
W4	7,534.67	11,869.06	2,626.18	5,109.69	3.22 x 0.105	1	C16 = 1.125 x 0.943 x .105
W5	2,042.92	13,593.73	5,861.27	6,466.92	2.29 x 0.115	1	C18 = 1.125 x 1.012 x .115
W6	4,187.87	7,215.59	1,459.66	1,747.28	2.45 x 0.077	1	C10 = 1.125 x 0.700 x 0.07
W7	969.44	11,869.06	2,781.38	5,109.69	2.00 x 0.105	1	C16 = 1.125 x 0.943 x .105
W8	2,781.38	7,215.59	969.44	1,747.28	2.00 x 0.077	1	C10 = 1.125 x 0.700 x 0.07
V1	338.99	7,215.59	1,105.66	3,351.65	2.00 x 0.077	1	C10 = 1.125 x 0.700 x 0.07
V2	405.01	7,215.59	1,295.07	3,417.05	2.00 x 0.077	1	C10 = 1.125 x 0.700 x 0.07

* Symmetrical Joist

STRESS ANALYSIS - PAGE 3



NEW MILLENNIUM
BUILDING SYSTEMS

Job Number: 8010-0704	Job Name: 10-123 BARRHAVEN FIRE STATION - SHOPORDERS	Date Run: 11/19/2010 3:56:50 PM
Location: OTTAWA, ON	Joist Description: Short Span Crimp 24K581/265	Mark: J11

TCX Design

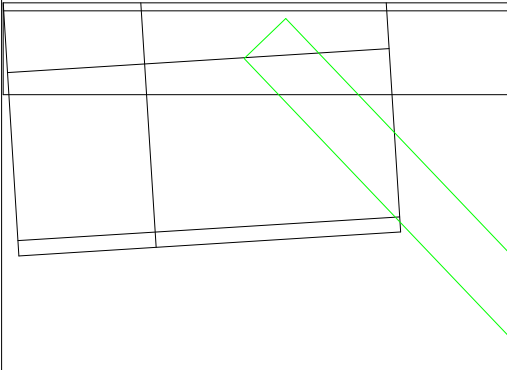
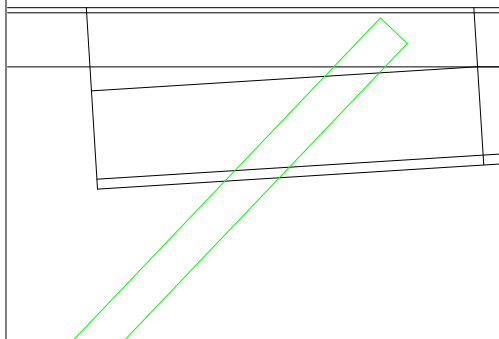
TCX Left		TCX Right	
TCX Length	0-2 1/4	TCX Length	0-0 3/4
TCX Type	R	TCX Type	R
TCX Depth	4	TCX Depth	4
BPL Length	0-6 1/4	BPL Length	0-10 5/8
Clear Bearing	0-6 3/8	Clear Bearing	0-6
BPL Material: 69L = 2 x 3 x .250		BPL Material: 27 = 2 1/2 x 2 1/2 x .250	
Total Load	581.00	Total Load	581.00
Reqd TL Def L/80	0.03	Reqd TL Def L/80	0.01
Live Load	397.50	Live Load	397.50
Reqd LL Def L/120	0.02	Reqd LL Def L/120	0.01
Section Modulus	0.1495	Section Modulus	0.1495
Reqd SM	0.0029	Reqd SM	0.0003
Mom of Inertia	0.1610	Mom of Inertia	0.1610
Reqd MI	0.0001	Reqd MI	0.0000
Seat Type: Lapped		Seat Type: Pegged or Butted	
			

LSD Design

- | | |
|--|---|
| <p>Case 1a: DL
 Case 1b: 1.4(DL)
 Case 2a: LL
 Case 2b: SL
 Case 3a: 1.25(DL+CL)+1.5(TL+LL)
 Case 3b: 1.25(DL+CL)+1.5(TL+SL)
 Case 3c: 1.25(DL+CL)+1.5(TL+LL+FEM)
 Case 3d: 1.25(DL+CL)+1.5(TL+SL+FEM)
 Case 3e: DL+CL+TL+LL
 Case 3f: DL+CL+TL+SL
 Case 4a: 1.25(DL)+0.5(CL+LL)+1.4(WL+AX)+0.8(TL)
 Case 4b: 1.25(DL)+0.5(CL+LL)+1.4(WL-AX)+0.8(TL)
 Case 4c: 1.25(DL)+0.5(CL+LL)+1.4(WL+AX+IP)+0.8(TL)
 Case 4d: 1.25(DL)+0.5(CL+LL)+1.4(WL-AX+IP)+0.8(TL)
 Case 4e: 1.25(DL+CL)+1.4(WL+AX)+1.1(TL)+LL
 Case 4f: 1.25(DL+CL)+1.4(WL-AX)+1.1(TL)+LL
 Case 5a: 0.9(DL)+1.4(WL+AX)
 Case 5b: 0.9(DL)+1.4(WL-AX)
 Case 5c: 0.9(DL)+1.4(WL+AX+IP)
 Case 5d: 0.9(DL)+1.4(WL-AX+IP)
 Case 5e: DL+SM+AX
 Case 5f: DL+SM-AX</p> | <p>Case 6a: 1.25(DL)+0.5(CL+SL)+1.4(WL+AX)+0.8(TL)
 Case 6b: 1.25(DL)+0.5(CL+SL)+1.4(WL-AX)+0.8(TL)
 Case 6c: 1.25(DL)+0.5(CL+SL)+1.4(WL+AX+IP)+0.8(TL)
 Case 6d: 1.25(DL)+0.5(CL+SL)+1.4(WL-AX+IP)+0.8(TL)
 Case 7a: 1.25(DL+CL)+0.4(WL+AX)+1.5(TL+LL)
 Case 7b: 1.25(DL+CL)+0.4(WL-AX)+1.5(TL+LL)
 Case 7c: 1.25(DL+CL)+0.4(WL+AX+IP)+1.5(TL+LL)
 Case 7d: 1.25(DL+CL)+0.4(WL-AX+IP)+1.5(TL+LL)
 Case 8a: 1.25(DL+CL)+0.4(WL+AX)+1.5(TL+SL)
 Case 8b: 1.25(DL+CL)+0.4(WL-AX)+1.5(TL+SL)
 Case 8c: 1.25(DL+CL)+0.4(WL+AX+IP)+1.5(TL+SL)
 Case 8d: 1.25(DL+CL)+0.4(WL-AX+IP)+1.5(TL+SL)
 Case 9a: DL+CL+0.5(LL)+0.7(TL)+SM+AX+FEM
 Case 9b: DL+CL+0.5(LL)+0.7(TL)+SM-AX+FEM
 Case 9c: DL+CL+0.25(SL)+0.7(TL)+SM+AX+FEM
 Case 9d: DL+CL+0.25(SL)+0.7(TL)+SM-AX+FEM
 Case 9e: DL+CL+LL+1.1(TL)+SM+AX+FEM
 Case 9f: DL+CL+LL+1.1(TL)+SM-AX+FEM
 Case 10a: DL+SM+AX
 Case 10b: DL+SM-AX
 Case 10c: DL+CL+SM+AX
 Case 10d: DL+CL+SM-AX</p> |
|--|---|

STRESS ANALYSIS - PAGE 1



NEW MILLENNIUM
BUILDING SYSTEMS

Job Number: 8010-0704	Job Name: 10-123 BARRHAVEN FIRE STATION - SHOPORDERS	Date Run: 11/19/2010 3:56:50 PM
Location: OTTAWA, ON	Joist Description: Short Span Crimp 24K581/265	Mark: J12

Geometry

Base Length: 26-11 1/8	Working Length: 26-7 1/8	Joist Depth: 24.00	Effective Depth: 22.80	BC Panel Length: 5 @ 4-0	Shape: Parallel Chords
----------------------------------	------------------------------------	------------------------------	----------------------------------	------------------------------------	----------------------------------

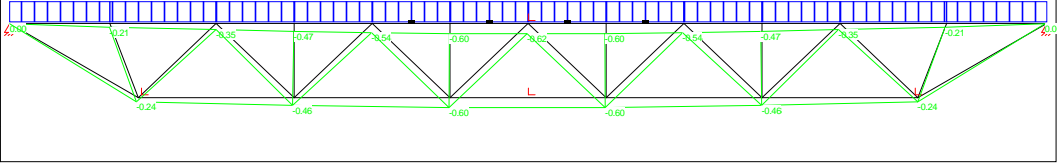
Variable	Left End	Right End	Deflection Case 2a: LL (Max Deflection: -0.62 in-Y, -0.11 in-X) 
BC Panel	3-5 1/2	3-5 1/2	
TC Panel	2-8 3/4	2-8 3/4	
First Half	2-0	2-0	
First Diag.	5-5 1/2	5-5 1/2	
Depth	24.00	24.00	

Loads, *** All loads are factored ***

Load Type	Category	Load1	Load2	Position	Direction	Loc/Begin	Sp/End
Uniform (plf)	DL	183.50	183.50	TC	+	0-0	26-11 1/8
Uniform (plf)	LL	397.50	397.50	TC	+	0-0	26-11 1/8
Conc anywhere (lbs)	TL	315.00	0.00	BC	+	13-5 5/8	0-0
Uniform (plf)	TL	409.00	409.00	TC	+	0-0	26-11 1/8
Net Uplift (plf)	WL	197.00	197.00	TC	-	0-0	26-11 1/8
Conc anywhere (lbs)	TL	315.00	0.00	TC	+	13-5 5/8	0-0

Stress Analysis Summary

Int. Panel TC: 24.00	Max Panel BC: 48.00	Reaction LE: 13,782.02	Reaction RE: 13,787.96	Minimum Shear: 3,446.99	Max TC Comp.: 46,890.59	Max BC Tension: 48,092.39
--------------------------------	-------------------------------	----------------------------------	----------------------------------	-----------------------------------	-----------------------------------	-------------------------------------

Member	TC Tension	TC Compression	BC Tension	BC Compression	Web Tension	Web Comp.	Web Length	PP Dist.
W2	4,227.95	21,216.82	0.00	0.00	25,099.16	4,878.13	45.61	0-2
V1S	4,019.02	20,195.41	0.00	0.00	576.07	3,656.61	24.43	2-8 3/4
W3	4,019.02	20,195.41	30,283.87	6,014.81	2,754.60	14,191.40	33.11	3-5 1/2
W4	7,505.55	37,903.24	30,283.87	6,014.81	10,792.93	2,059.44	33.11	5-5 1/2
W5	7,505.55	37,903.24	43,438.82	8,570.04	1,471.47	7,780.40	33.11	7-5 1/2
W6	9,208.29	46,890.59	43,438.82	8,570.04	5,004.19	977.28	33.11	9-5 1/2
W7	9,208.29	46,890.59	48,092.39	9,420.30	977.28	5,004.19	33.11	11-5 1/2

* Symmetrical Joist

Standard Verticals

Member	Position	Max Tension	Max Comp.	Length
V2	Interior	405.01	2,844.45	22.80

STRESS ANALYSIS - PAGE 2



NEW MILLENNIUM
BUILDING SYSTEMS

Job Number: 8010-0704	Job Name: 10-123 BARRHAVEN FIRE STATION - SHOPORDERS	Date Run: 11/19/2010 3:56:50 PM
Location: OTTAWA, ON	Joist Description: Short Span Crimp 24K581/265	Mark: J12

Chord Properties

Chord	Area	Rx	Rz	Ryy	Y	Ix	Q	Material
TC	0.7155	0.6489	0.3818	1.3483	0.6194	0.3013	1.0000	A36 = 2.0938 x .187
BC	0.6208	0.6001	0.3508	1.2870	0.5761	0.2235	1.0000	A34 = 1.9375 x .176

Axial and Bending Analysis

K: 1.00	Fy: 50,000.00	Fb: 45,000.00	Mom of Inertia: 346.24	LL 360: 687.77	LL 240: 1,031.65	Max Bridg TC: 16-3 1/2	Max Bridg BC: 17-9
-------------------	-------------------------	-------------------------	----------------------------------	--------------------------	----------------------------	----------------------------------	------------------------------

Top Chord Check	End Panel LE	First Panel LE	Interior Panel	First Panel RE	End Panel RE	
Length	30.75	32.75	24.00	32.88	30.75	Gap Between Chords: 1.1250
Bending Load	947.24	947.24	947.24	947.24	947.24	Min Weld Len 2X: 0.5000
Axial Load	21,149.88	20,144.84	46,890.59	20,195.41	21,216.82	Max Load Fillers TC: 55,645.05
fa	14,779.64	14,077.31	32,767.37	14,112.65	14,826.41	Max Load no Fillers TC: 46,141.78
Maximum K L/r	80.54	85.78	36.99	86.11	80.54	TC OAL/Ryy: 236.6901
Fcr	31,115.76	29,195.34	45,240.94	29,075.46	31,115.76	BC Stress: 42,999.64
Fa	28,004.18	26,275.81	40,716.85	26,167.91	28,004.18	BC L/Rz: 136.8117
F'e	127,456.20	112,364.36	209,232.27	111,511.50	127,456.20	TC Shear Stress: 22,330.51
Cm	0.9613	0.9582	0.9304	0.9578	0.9612	BC Shear Stress: 26,062.37
Panel Point Moment	9769.53	9306.07	4488.96	9335.49	9798.90	
Mid Panel Moment	6576.74	4278.02	2485.10	4321.83	6565.45	
Panel Point fb	23904.97	22770.94	10983.99	22842.93	23976.85	
Mid Panel fb	6760.16	4397.33	2554.41	4442.36	6748.55	
Fillers	0	0	4	0	0	
Panel Point Stress	38,684.61	36,848.25	43,751.36	36,955.57	38,803.26	
Mid Panel Stress	0.6751	0.6324	0.8616	0.6371	0.6766	

Web Design

Member	Web Tension	Allow Tension	Web Comp	Allow Comp	Weld	Qty	Material
W2	25,099.16	25,388.77	4,878.13	10,613.36	6.40 x 0.176	1	C34 = 1.125 x 1.549 x .176
W3	2,754.60	36,889.49	14,191.40	17,650.42	3.40 x 0.188	1	C38 = 1.125 x 1.844 x .200
W4	10,792.93	11,869.06	2,059.44	5,445.92	4.61 x 0.105	1	C16 = 1.125 x 0.943 x .105
W5	1,471.47	16,459.83	7,780.40	8,879.03	2.61 x 0.134	1	C22 = 1.125 x 1.086 x .134
W6	5,004.19	7,215.59	977.28	1,901.53	2.93 x 0.077	1	C10 = 1.125 x 0.700 x 0.07
W7	977.28	11,869.06	5,004.19	5,445.92	2.14 x 0.105	1	C16 = 1.125 x 0.943 x .105
V1	576.07	8,461.40	3,656.61	3,974.99	2.00 x 0.090	1	C12 = 1.125 x 0.715 x .090
V2	405.01	7,215.59	2,844.45	3,650.67	2.00 x 0.077	1	C10 = 1.125 x 0.700 x 0.07

* Symmetrical Joist

STRESS ANALYSIS - PAGE 3



NEW MILLENNIUM
BUILDING SYSTEMS

<i>Job Number:</i> 8010-0704	<i>Job Name:</i> 10-123 BARRHAVEN FIRE STATION - SHOPORDERS	<i>Date Run:</i> 11/19/2010 3:56:50 PM
<i>Location:</i> OTTAWA, ON	<i>Joist Description:</i> Short Span Crimp 24K581/265	<i>Mark:</i> J12

TCX Design

TCX Left		TCX Right	
TCX Length	0-2 1/4	TCX Length	0-0 3/4
TCX Type	R	TCX Type	R
TCX Depth	4	TCX Depth	4
BPL Length	0-6 1/4	BPL Length	0-4 3/4
Clear Bearing	0-7 1/8	Clear Bearing	0-7 3/8
BPL Material: 69L = 2 x 3 x .250		BPL Material: 69L = 2 x 3 x .250	

Total Load	581.00	Total Load	581.00
Reqd TL Def L/80	0.03	Reqd TL Def L/80	0.01
Live Load	397.50	Live Load	397.50
Reqd LL Def L/120	0.02	Reqd LL Def L/120	0.01
Section Modulus	0.4087	Section Modulus	0.4087
Reqd SM	0.0029	Reqd SM	0.0003
Mom of Inertia	0.6026	Mom of Inertia	0.6026
Reqd MI	0.0001	Reqd MI	0.0000

Seat Type: Lapped

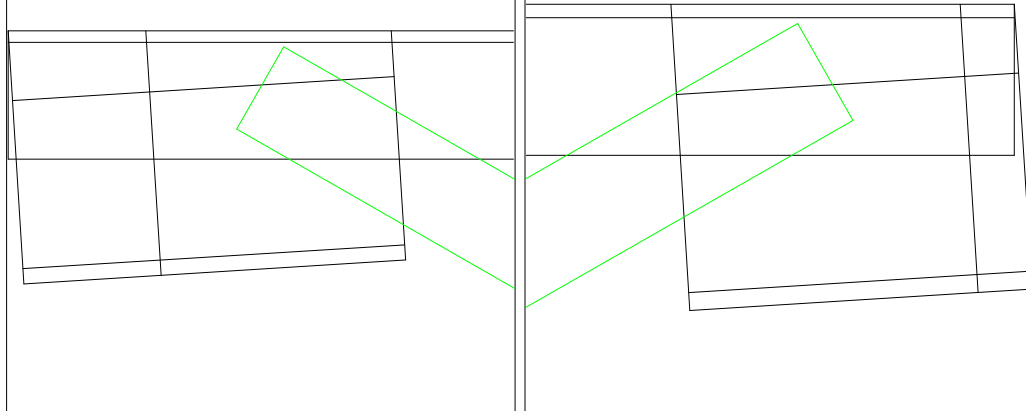

LSD Design

- | | |
|--|--|
| Case 1a: DL | Case 6a: 1.25(DL)+0.5(CL+SL)+1.4(WL+AX)+0.8(TL) |
| Case 1b: 1.4(DL) | Case 6b: 1.25(DL)+0.5(CL+SL)+1.4(WL-AX)+0.8(TL) |
| Case 2a: LL | Case 6c: 1.25(DL)+0.5(CL+SL)+1.4(WL+AX+IP)+0.8(TL) |
| Case 2b: SL | Case 6d: 1.25(DL)+0.5(CL+SL)+1.4(WL-AX+IP)+0.8(TL) |
| Case 3a: 1.25(DL+CL)+1.5(TL+LL) | Case 7a: 1.25(DL+CL)+0.4(WL+AX)+1.5(TL+LL) |
| Case 3b: 1.25(DL+CL)+1.5(TL+SL) | Case 7b: 1.25(DL+CL)+0.4(WL-AX)+1.5(TL+LL) |
| Case 3c: 1.25(DL+CL)+1.5(TL+LL+FEM) | Case 7c: 1.25(DL+CL)+0.4(WL+AX+IP)+1.5(TL+LL) |
| Case 3d: 1.25(DL+CL)+1.5(TL+SL+FEM) | Case 7d: 1.25(DL+CL)+0.4(WL-AX+IP)+1.5(TL+LL) |
| Case 3e: DL+CL+TL+LL | Case 8a: 1.25(DL+CL)+0.4(WL+AX)+1.5(TL+SL) |
| Case 3f: DL+CL+TL+SL | Case 8b: 1.25(DL+CL)+0.4(WL-AX)+1.5(TL+SL) |
| Case 4a: 1.25(DL)+0.5(CL+LL)+1.4(WL+AX)+0.8(TL) | Case 8c: 1.25(DL+CL)+0.4(WL+AX+IP)+1.5(TL+SL) |
| Case 4b: 1.25(DL)+0.5(CL+LL)+1.4(WL-AX)+0.8(TL) | Case 8d: 1.25(DL+CL)+0.4(WL-AX+IP)+1.5(TL+SL) |
| Case 4c: 1.25(DL)+0.5(CL+LL)+1.4(WL+AX+IP)+0.8(TL) | Case 9a: DL+CL+0.5(LL)+0.7(TL)+SM+AX+FEM |
| Case 4d: 1.25(DL)+0.5(CL+LL)+1.4(WL-AX+IP)+0.8(TL) | Case 9b: DL+CL+0.5(LL)+0.7(TL)+SM-AX+FEM |
| Case 4e: 1.25(DL+CL)+1.4(WL+AX)+1.1(TL)+LL | Case 9c: DL+CL+0.25(SL)+0.7(TL)+SM+AX+FEM |
| Case 4f: 1.25(DL+CL)+1.4(WL-AX)+1.1(TL)+LL | Case 9d: DL+CL+0.25(SL)+0.7(TL)+SM-AX+FEM |
| Case 5a: 0.9(DL)+1.4(WL+AX) | Case 9e: DL+CL+LL+1.1(TL)+SM+AX+FEM |
| Case 5b: 0.9(DL)+1.4(WL-AX) | Case 9f: DL+CL+LL+1.1(TL)+SM-AX+FEM |
| Case 5c: 0.9(DL)+1.4(WL+AX+IP) | Case 10a: DL+SM+AX |
| Case 5d: 0.9(DL)+1.4(WL-AX+IP) | Case 10b: DL+SM-AX |
| Case 5e: DL+SM+AX | Case 10c: DL+CL+SM+AX |
| Case 5f: DL+SM-AX | Case 10d: DL+CL+SM-AX |

STRESS ANALYSIS - PAGE 1



NEW MILLENNIUM
BUILDING SYSTEMS

Job Number: 8010-0704	Job Name: 10-123 BARRHAVEN FIRE STATION - SHOPORDERS	Date Run: 11/19/2010 3:58:33 PM
Location: OTTAWA, ON	Joist Description: Short Span Crimp 20K469/214	Mark: J13

Geometry

Base Length: 18-11 7/8	Working Length: 18-7 7/8	Joist Depth: 20.00	Effective Depth: 18.87	BC Panel Length: 4 @ 4-0	Shape: Parallel Chords
----------------------------------	------------------------------------	------------------------------	----------------------------------	------------------------------------	----------------------------------

Variable	Left End	Right End
BC Panel	1-9 3/8	1-9 3/8
TC Panel	1-8 7/8	1-8 7/8
First Half	1-8 1/2	1-8 5/8
First Diag.	3-5 7/8	3-6
Depth	20.00	20.00

Deflection Case 2a: LL (Max Deflection: -0.38 in-Y, -0.07 in-X)

Loads, *** All loads are factored ***

Load Type	Category	Load1	Load2	Position	Direction	Loc/Begin	Sp/End
Uniform (plf)	DL	147.00	147.00	TC	+	0-0	18-11 7/8
Uniform (plf)	LL	321.00	321.00	TC	+	0-0	18-11 7/8
Net Uplift (plf)	WL	204.00	204.00	TC	-	0-0	18-11 7/8
Uniform (plf)	LL	238.00	883.00	TC	+	0-0	18-9 3/8
Conc anywhere (lbs)	TL	315.00	0.00	BC	+	9-5 7/8	0-0
Conc anywhere (lbs)	TL	315.00	0.00	TC	+	9-5 7/8	0-0

Stress Analysis Summary

Int. Panel TC: 24.00	Max Panel BC: 48.00	Reaction LE: 9,199.03	Reaction RE: 11,223.38	Minimum Shear: 2,805.84	Max TC Comp.: 30,327.34	Max BC Tension: 29,234.68
--------------------------------	-------------------------------	---------------------------------	----------------------------------	-----------------------------------	-----------------------------------	-------------------------------------

Member	TC Tension	TC Compression	BC Tension	BC Compression	Web Tension	Web Comp.	Web Length	PP Dist.
W2	1,828.02	10,130.26	0.00	0.00	14,579.38	2,551.60	27.04	0-2
V1S	1,818.84	10,073.06	0.00	0.00	347.47	2,881.33	18.87	1-8 7/8
W3	1,818.84	10,073.06	18,497.54	3,385.07	2,122.77	11,707.89	27.86	1-9 3/8
W4	4,709.19	25,350.05	18,497.54	3,385.07	9,244.32	1,687.82	30.53	3-5 7/8
W5	4,709.19	25,350.05	29,234.68	5,503.10	1,013.39	6,157.51	30.53	5-5 7/8
W6	5,766.82	30,327.34	29,234.68	5,503.10	4,539.92	786.39	30.53	7-5 7/8

* Symmetrical Joist

Standard Verticals

Member	Position	Max Tension	Max Comp.	Length
V2	Interior	515.57	3,114.86	18.87

STRESS ANALYSIS - PAGE 2



NEW MILLENNIUM
BUILDING SYSTEMS

Job Number: 8010-0704	Job Name: 10-123 BARRHAVEN FIRE STATION - SHOPORDERS	Date Run: 11/19/2010 3:58:33 PM
Location: OTTAWA, ON		Joist Description: Short Span Crimp 20K469/214
		Mark: J13

Chord Properties

Chord	Area	Rx	Rz	Ryy	Y	Ix	Q	Material
TC	0.6208	0.6001	0.3508	1.2870	0.5761	0.2235	1.0000	A34 = 1.9375 x .176
BC	0.5636	0.5816	0.3394	1.2607	0.5561	0.1906	1.0000	A32 = 1.8750 x .165

Axial and Bending Analysis

K: 1.00	Fy: 50,000.00	Fb: 45,000.00	Mom of Inertia: 210.73	LL 300: 1,454.89	TL 480: 909.31	Max Bridg TC: 15-6 5/8	Max Bridg BC: 21-7
-------------------	-------------------------	-------------------------	----------------------------------	----------------------------	--------------------------	----------------------------------	------------------------------

Top Chord Check	End Panel LE	First Panel LE	Interior Panel	First Panel RE	End Panel RE	
Length	18.88	21.00	24.00	21.13	18.88	Gap Between Chords: 1.1250
Bending Load	704.38	0.00	1,034.08	1,237.38	1,295.00	Min Weld Len 2X: 0.5000
Axial Load	8,559.18	8,525.64	30,327.34	10,073.06	10,130.26	Max Load Fillers TC: 46,282.76
fa	6,894.00	6,866.98	24,427.18	8,113.36	8,159.43	Max Load no Fillers TC: 37,064.63
Maximum K L/r	53.80	59.86	68.41	60.21	53.80	TC OAL/Ryy: 173.9454
Fcr	40,463.59	38,477.39	35,512.37	38,357.23	40,463.59	BC Stress: 30,781.59
Fa	36,417.23	34,629.65	31,961.13	34,521.50	36,417.23	BC L/Rz: 141.4125
F'e	289,268.81	233,688.28	178,917.59	230,930.92	289,268.81	TC Shear Stress: 20,381.18
Cm	0.9921	0.9902	0.9393	0.9883	0.9906	BC Shear Stress: 22,537.22
Panel Point Moment	3011.77	700.00	4836.32	4761.21	4966.33	
Mid Panel Moment	2238.21	590.63	2658.79	2147.74	3561.70	
Panel Point fb	9172.10	2131.79	14728.61	14499.86	15124.54	
Mid Panel fb	2884.44	761.15	3426.44	2767.85	4590.05	
Fillers	0	0	0	0	0	
Panel Point Stress	16,066.10	8,998.77	39,155.79	22,613.21	23,283.97	
Mid Panel Stress	0.1600	0.1165	0.8392	0.2913	0.3168	

Web Design

Member	Web Tension	Allow Tension	Web Comp	Allow Comp	Weld	Qty	Material
W2	14,579.38	14,813.85	2,551.60	10,260.70	4.88 x 0.134	1	C22 = 1.125 x 1.086 x .134
W3	2,122.77	21,718.85	11,707.89	12,220.09	3.50 x 0.150	1	C28 = 1.125 x 1.347 x .150
W4	9,244.32	9,485.80	1,687.82	2,849.36	3.95 x 0.105	1	C14 = 1.125 x 0.693 x .105
W5	1,013.39	11,869.06	6,157.51	6,218.28	2.63 x 0.105	1	C16 = 1.125 x 0.943 x .105
W6	4,539.92	7,215.59	786.39	2,329.49	2.66 x 0.077	1	C10 = 1.125 x 0.700 x 0.07
V1	347.47	7,215.59	2,881.33	4,520.52	2.00 x 0.077	1	C10 = 1.125 x 0.700 x 0.07
V2	515.57	7,215.59	3,114.86	4,521.83	2.00 x 0.077	1	C10 = 1.125 x 0.700 x 0.07

* Symmetrical Joist

STRESS ANALYSIS - PAGE 3



NEW MILLENNIUM
BUILDING SYSTEMS

<i>Job Number:</i> 8010-0704	<i>Job Name:</i> 10-123 BARRHAVEN FIRE STATION - SHOPORDERS	<i>Date Run:</i> 11/19/2010 3:58:33 PM
<i>Location:</i> OTTAWA, ON	<i>Joist Description:</i> Short Span Crimp 20K469/214	<i>Mark:</i> J13

TCX Design

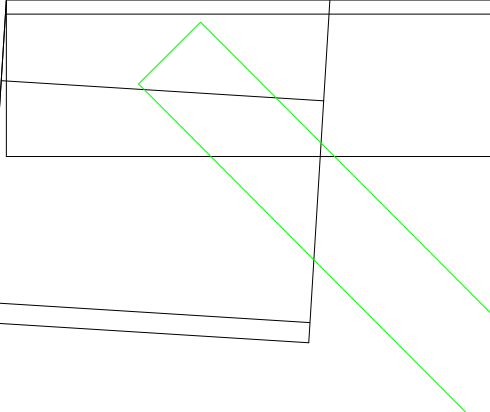
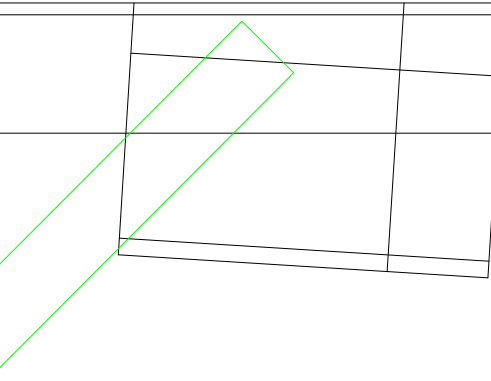
TCX Left		TCX Right	
TCX Length	0-0	TCX Length	0-1 1/2
TCX Type	R	TCX Type	R
TCX Depth	4	TCX Depth	4
BPL Length	0-4	BPL Length	0-5 1/2
Clear Bearing	0-5 1/8	Clear Bearing	0-5 5/8
BPL Material: 69L = 2 x 3 x .250		BPL Material: 69L = 2 x 3 x .250	
Total Load	468.00	Total Load	468.00
Reqd TL Def L/80	0.00	Reqd TL Def L/80	0.02
Live Load	321.00	Live Load	321.00
Reqd LL Def L/120	0.00	Reqd LL Def L/120	0.01
Section Modulus	0.0000	Section Modulus	0.3284
Reqd SM	0.0000	Reqd SM	0.0010
Mom of Inertia	0.0000	Mom of Inertia	0.4470
Reqd MI	0.0000	Reqd MI	0.0000
Seat Type: Lapped		Seat Type: Lapped	
			

LSD Design

- | | |
|--|---|
| <p>Case 1a: DL
 Case 1b: 1.4(DL)
 Case 2a: LL
 Case 2b: SL
 Case 3a: 1.25(DL+CL)+1.5(TL+LL)
 Case 3b: 1.25(DL+CL)+1.5(TL+SL)
 Case 3c: 1.25(DL+CL)+1.5(TL+LL+FEM)
 Case 3d: 1.25(DL+CL)+1.5(TL+SL+FEM)
 Case 3e: DL+CL+TL+LL
 Case 3f: DL+CL+TL+SL
 Case 4a: 1.25(DL)+0.5(CL+LL)+1.4(WL+AX)+0.8(TL)
 Case 4b: 1.25(DL)+0.5(CL+LL)+1.4(WL-AX)+0.8(TL)
 Case 4c: 1.25(DL)+0.5(CL+LL)+1.4(WL+AX+IP)+0.8(TL)
 Case 4d: 1.25(DL)+0.5(CL+LL)+1.4(WL-AX+IP)+0.8(TL)
 Case 4e: 1.25(DL+CL)+1.4(WL+AX)+1.1(TL)+LL
 Case 4f: 1.25(DL+CL)+1.4(WL-AX)+1.1(TL)+LL
 Case 5a: 0.9(DL)+1.4(WL+AX)
 Case 5b: 0.9(DL)+1.4(WL-AX)
 Case 5c: 0.9(DL)+1.4(WL+AX+IP)
 Case 5d: 0.9(DL)+1.4(WL-AX+IP)
 Case 5e: DL+SM+AX
 Case 5f: DL+SM-AX</p> | <p>Case 6a: 1.25(DL)+0.5(CL+SL)+1.4(WL+AX)+0.8(TL)
 Case 6b: 1.25(DL)+0.5(CL+SL)+1.4(WL-AX)+0.8(TL)
 Case 6c: 1.25(DL)+0.5(CL+SL)+1.4(WL+AX+IP)+0.8(TL)
 Case 6d: 1.25(DL)+0.5(CL+SL)+1.4(WL-AX+IP)+0.8(TL)
 Case 7a: 1.25(DL+CL)+0.4(WL+AX)+1.5(TL+LL)
 Case 7b: 1.25(DL+CL)+0.4(WL-AX)+1.5(TL+LL)
 Case 7c: 1.25(DL+CL)+0.4(WL+AX+IP)+1.5(TL+LL)
 Case 7d: 1.25(DL+CL)+0.4(WL-AX+IP)+1.5(TL+LL)
 Case 8a: 1.25(DL+CL)+0.4(WL+AX)+1.5(TL+SL)
 Case 8b: 1.25(DL+CL)+0.4(WL-AX)+1.5(TL+SL)
 Case 8c: 1.25(DL+CL)+0.4(WL+AX+IP)+1.5(TL+SL)
 Case 8d: 1.25(DL+CL)+0.4(WL-AX+IP)+1.5(TL+SL)
 Case 9a: DL+CL+0.5(LL)+0.7(TL)+SM+AX+FEM
 Case 9b: DL+CL+0.5(LL)+0.7(TL)+SM-AX+FEM
 Case 9c: DL+CL+0.25(SL)+0.7(TL)+SM+AX+FEM
 Case 9d: DL+CL+0.25(SL)+0.7(TL)+SM-AX+FEM
 Case 9e: DL+CL+LL+1.1(TL)+SM+AX+FEM
 Case 9f: DL+CL+LL+1.1(TL)+SM-AX+FEM
 Case 10a: DL+SM+AX
 Case 10b: DL+SM-AX
 Case 10c: DL+CL+SM+AX
 Case 10d: DL+CL+SM-AX</p> |
|--|---|

STRESS ANALYSIS - PAGE 1



NEW MILLENNIUM
BUILDING SYSTEMS

Job Number: 8010-0704	Job Name: 10-123 BARRHAVEN FIRE STATION - SHOPORDERS	Date Run: 11/19/2010 3:58:47 PM
Location: OTTAWA, ON	Joist Description: Short Span Crimp 20K469/214	Mark: J14

Geometry

Base Length: 18-11 7/8	Working Length: 18-7 7/8	Joist Depth: 20.00	Effective Depth: 18.80	BC Panel Length: 4 @ 4-0	Shape: Parallel Chords
----------------------------------	------------------------------------	------------------------------	----------------------------------	------------------------------------	----------------------------------

Variable	Left End	Right End
BC Panel	1-9 3/8	1-9 3/8
TC Panel	1-8 7/8	1-8 7/8
First Half	1-8 1/2	1-8 5/8
First Diag.	3-5 7/8	3-6
Depth	20.00	20.00

Deflection Case 2a: LL (Max Deflection: -0.27 in-Y, -0.05 in-X)

Loads, *** All loads are factored ***

Load Type	Category	Load1	Load2	Position	Direction	Loc/Begin	Sp/End
Uniform (plf)	DL	147.00	147.00	TC	+	0-0	18-11 7/8
Uniform (plf)	LL	321.00	321.00	TC	+	0-0	18-11 7/8
Uniform (plf)	LL	238.00	883.00	TC	+	0-0	18-9 3/8
Net Uplift (plf)	WL	204.00	204.00	TC	-	0-0	18-11 7/8
Conc Load (lbs)	LL	1,700.00	0.00	TC	+	5-0	11-0
Conc Load (lbs)	LL	3,375.00	0.00	TC	+	9-0	15-0
Conc anywhere (lbs)	TL	315.00	0.00	TC	+	9-5 7/8	0-0
Conc anywhere (lbs)	TL	315.00	0.00	BC	+	9-5 7/8	0-0
Conc Load (lbs)	LL	1,700.00	0.00	TC	+	12-0	18-0

Stress Analysis Summary

Int. Panel TC: 24.00	Max Panel BC: 48.00	Reaction LE: 12,852.58	Reaction RE: 16,450.57	Minimum Shear: 4,112.64	Max TC Comp.: 49,250.39	Max BC Tension: 45,708.34
--------------------------------	-------------------------------	----------------------------------	----------------------------------	-----------------------------------	-----------------------------------	-------------------------------------

Member	TC Tension	TC Compression	BC Tension	BC Compression	Web Tension	Web Comp.	Web Length	PP Dist.
W2	1,834.50	13,892.30	0.00	0.00	22,111.95	2,556.25	27.00	0-2
V1S	1,825.29	13,834.90	0.00	0.00	347.47	8,136.05	18.81	1-8 7/8
W3	1,825.29	13,834.90	26,255.77	3,397.07	2,126.87	19,148.69	27.82	1-9 3/8
W4	4,725.88	37,748.16	26,255.77	3,397.07	17,156.92	1,691.52	30.49	3-5 7/8
W5	4,725.88	37,748.16	45,708.34	5,522.61	3,188.83	11,685.73	30.49	5-5 7/8
W6	5,787.26	49,250.39	45,708.34	5,522.61	8,574.99	3,374.39	30.49	7-5 7/8
V3	5,787.26	49,250.39	45,708.34	5,522.61	5,590.57	8,007.89	18.80	9-5 7/8

* Symmetrical Joist

Standard Verticals

Member	Position	Max Tension	Max Comp.	Length
V2	Interior	5,590.57	8,284.47	18.80

STRESS ANALYSIS - PAGE 2



NEW MILLENNIUM
BUILDING SYSTEMS

Job Number: 8010-0704	Job Name: 10-123 BARRHAVEN FIRE STATION - SHOPORDERS	Date Run: 11/19/2010 3:58:47 PM
Location: OTTAWA, ON	Joist Description: Short Span Crimp 20K469/214	Mark: J14

Chord Properties

Chord	Area	Rx	Rz	Ryy	Y	Ix	Q	Material
TC	0.8173	0.6134	0.3924	1.2963	0.5795	0.3076	1.0000	20 = 2 x 2 x .216
BC	0.7155	0.6489	0.3818	1.3483	0.6194	0.3013	1.0000	A36 = 2.0938 x .187

Axial and Bending Analysis

K: 1.00	Fy: 50,000.00	Fb: 45,000.00	Mom of Inertia: 270.33	LL 300: 1,866.41	TL 480: 1,166.51	Max Bridg TC: 15-8	Max Bridg BC: 26-4 3/4
-------------------	-------------------------	-------------------------	----------------------------------	----------------------------	----------------------------	------------------------------	----------------------------------

Top Chord Check	End Panel LE	First Panel LE	Interior Panel	First Panel RE	End Panel RE	Gap Between Chords: 1.1250
Length	18.88	21.00	24.00	21.13	18.88	Min Weld Len 2X: 0.5000
Bending Load	704.38	0.00	1,034.08	1,237.38	1,295.00	Max Load Fillers TC: 62,829.27
Axial Load	11,845.16	11,811.49	49,250.39	13,834.90	13,892.30	Max Load no Fillers TC: 53,543.55
fa	7,246.13	7,225.53	30,128.31	8,463.33	8,498.44	TC OAL/Ryy: 172.7053
Maximum K L/r	48.10	53.51	61.16	53.83	48.10	BC Stress: 35,366.85
Fcr	42,219.46	40,554.73	38,037.00	40,453.48	42,219.46	BC L/Rz: 125.7236
Fa	37,997.52	36,499.26	34,233.30	36,408.13	37,997.52	TC Shear Stress: 18,471.74
F'e	302,298.84	244,214.72	186,976.89	241,333.14	302,298.84	BC Shear Stress: 26,414.50
Cm	0.9920	0.9901	0.9284	0.9883	0.9906	
Panel Point Moment	3011.77	700.00	4836.32	4761.21	4966.33	
Mid Panel Moment	2238.21	590.63	2658.79	2147.74	3561.70	
Panel Point fb	6955.50	1616.61	11169.18	10995.71	11469.43	
Mid Panel fb	2108.51	556.40	2504.72	2023.28	3355.31	
Fillers	0	0	0	0	0	
Panel Point Stress	14,201.63	8,842.14	41,297.50	19,459.04	19,967.87	
Mid Panel Stress	0.1431	0.1116	0.9360	0.2736	0.2914	

Web Design

Member	Web Tension	Allow Tension	Web Comp	Allow Comp	Weld	Qty	Material
W2	22,111.95	22,785.30	2,556.25	15,054.41	6.09 x 0.163	1	C32 = 1.125 x 1.479 x .163
W3	2,126.87	36,889.49	19,148.69	20,002.81	4.59 x 0.188	1	C38 = 1.125 x 1.844 x .200
W4	17,156.92	21,718.85	1,691.52	11,921.07	5.14 x 0.150	1	C28 = 1.125 x 1.347 x .150
W5	3,188.83	21,718.85	11,685.73	11,921.07	3.50 x 0.150	1	C28 = 1.125 x 1.347 x .150
W6	8,574.99	11,869.06	3,374.39	6,329.97	3.67 x 0.105	1	C16 = 1.125 x 0.943 x .105
V1	347.47	13,593.73	8,136.05	9,320.80	3.18 x 0.115	1	C18 = 1.125 x 1.012 x .115
V2	5,590.57	7,215.59	8,284.47	4,586.17	2.55 x 0.077	1	C10 = 1.125 x 0.700 x 0.07

* Symmetrical Joist

STRESS ANALYSIS - PAGE 3



NEW MILLENNIUM
BUILDING SYSTEMS

Job Number: 8010-0704	Job Name: 10-123 BARRHAVEN FIRE STATION - SHOPORDERS	Date Run: 11/19/2010 3:58:47 PM
Location: OTTAWA, ON	Joist Description: Short Span Crimp 20K469/214	Mark: J14

TCX Design

TCX Left		TCX Right	
TCX Length	0-0	TCX Length	0-1 1/2
TCX Type	R	TCX Type	R
TCX Depth	4	TCX Depth	4
BPL Length	0-4	BPL Length	0-5 1/2
Clear Bearing	0-4 3/4	Clear Bearing	0-5 7/8
BPL Material: 69L = 2 x 3 x .250		BPL Material: 69L = 2 x 3 x .250	

Total Load	468.00	Total Load	468.00
Reqd TL Def L/80	0.00	Reqd TL Def L/80	0.02
Live Load	321.00	Live Load	321.00
Reqd LL Def L/120	0.00	Reqd LL Def L/120	0.01
Section Modulus	0.0000	Section Modulus	0.4330
Reqd SM	0.0000	Reqd SM	0.0010
Mom of Inertia	0.0000	Mom of Inertia	0.6151
Reqd MI	0.0000	Reqd MI	0.0000

Seat Type: Lapped

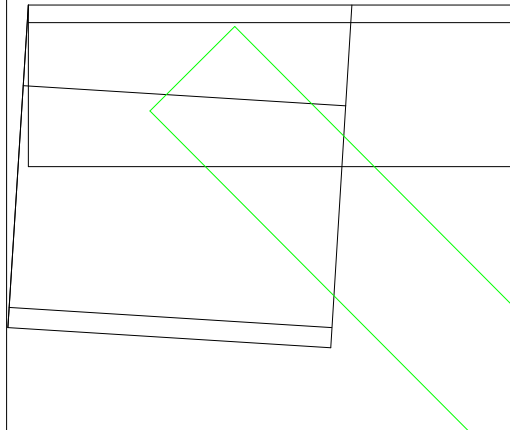

Seat Type: Lapped

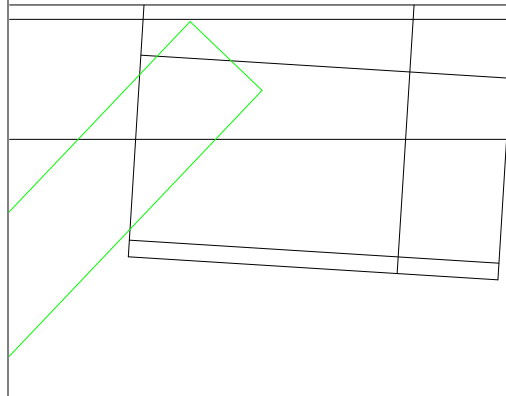

LSD Design

- | | |
|--|--|
| Case 1a: DL | Case 6a: 1.25(DL)+0.5(CL+SL)+1.4(WL+AX)+0.8(TL) |
| Case 1b: 1.4(DL) | Case 6b: 1.25(DL)+0.5(CL+SL)+1.4(WL-AX)+0.8(TL) |
| Case 2a: LL | Case 6c: 1.25(DL)+0.5(CL+SL)+1.4(WL+AX+IP)+0.8(TL) |
| Case 2b: SL | Case 6d: 1.25(DL)+0.5(CL+SL)+1.4(WL-AX+IP)+0.8(TL) |
| Case 3a: 1.25(DL+CL)+1.5(TL+LL) | Case 7a: 1.25(DL+CL)+0.4(WL+AX)+1.5(TL+LL) |
| Case 3b: 1.25(DL+CL)+1.5(TL+SL) | Case 7b: 1.25(DL+CL)+0.4(WL-AX)+1.5(TL+LL) |
| Case 3c: 1.25(DL+CL)+1.5(TL+LL+FEM) | Case 7c: 1.25(DL+CL)+0.4(WL+AX+IP)+1.5(TL+LL) |
| Case 3d: 1.25(DL+CL)+1.5(TL+SL+FEM) | Case 7d: 1.25(DL+CL)+0.4(WL-AX+IP)+1.5(TL+LL) |
| Case 3e: DL+CL+TL+LL | Case 8a: 1.25(DL+CL)+0.4(WL+AX)+1.5(TL+SL) |
| Case 3f: DL+CL+TL+SL | Case 8b: 1.25(DL+CL)+0.4(WL-AX)+1.5(TL+SL) |
| Case 4a: 1.25(DL)+0.5(CL+LL)+1.4(WL+AX)+0.8(TL) | Case 8c: 1.25(DL+CL)+0.4(WL+AX+IP)+1.5(TL+SL) |
| Case 4b: 1.25(DL)+0.5(CL+LL)+1.4(WL-AX)+0.8(TL) | Case 8d: 1.25(DL+CL)+0.4(WL-AX+IP)+1.5(TL+SL) |
| Case 4c: 1.25(DL)+0.5(CL+LL)+1.4(WL+AX+IP)+0.8(TL) | Case 9a: DL+CL+0.5(LL)+0.7(TL)+SM+AX+FEM |
| Case 4d: 1.25(DL)+0.5(CL+LL)+1.4(WL-AX+IP)+0.8(TL) | Case 9b: DL+CL+0.5(LL)+0.7(TL)+SM-AX+FEM |
| Case 4e: 1.25(DL+CL)+1.4(WL+AX)+1.1(TL)+LL | Case 9c: DL+CL+0.25(SL)+0.7(TL)+SM+AX+FEM |
| Case 4f: 1.25(DL+CL)+1.4(WL-AX)+1.1(TL)+LL | Case 9d: DL+CL+0.25(SL)+0.7(TL)+SM-AX+FEM |
| Case 5a: 0.9(DL)+1.4(WL+AX) | Case 9e: DL+CL+LL+1.1(TL)+SM+AX+FEM |
| Case 5b: 0.9(DL)+1.4(WL-AX) | Case 9f: DL+CL+LL+1.1(TL)+SM-AX+FEM |
| Case 5c: 0.9(DL)+1.4(WL+AX+IP) | Case 10a: DL+SM+AX |
| Case 5d: 0.9(DL)+1.4(WL-AX+IP) | Case 10b: DL+SM-AX |
| Case 5e: DL+SM+AX | Case 10c: DL+CL+SM+AX |
| Case 5f: DL+SM-AX | Case 10d: DL+CL+SM-AX |

STRESS ANALYSIS - PAGE 1



NEW MILLENNIUM
BUILDING SYSTEMS

Job Number: 8010-0704	Job Name: 10-123 BARRHAVEN FIRE STATION - SHOPORDERS	Date Run: 11/19/2010 3:58:59 PM
Location: OTTAWA, ON	Joist Description: Short Span Crimp 20K630/288	Mark: J16

Geometry

Base Length: 18-11 1/4	Working Length: 18-7 1/4	Joist Depth: 20.00	Effective Depth: 18.80	BC Panel Length: 4 @ 4-0	Shape: Parallel Chords
----------------------------------	------------------------------------	------------------------------	----------------------------------	------------------------------------	----------------------------------

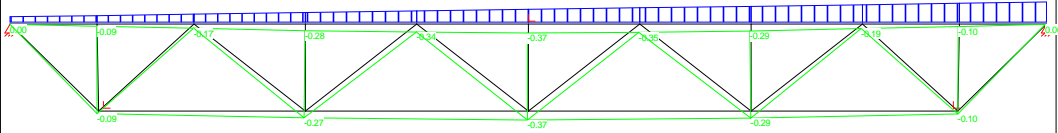
Variable	Left End	Right End	Deflection Case 2a: LL (Max Deflection: -0.37 in-Y, -0.07 in-X) 
BC Panel	1-9 1/8	1-9 1/8	
TC Panel	1-8 3/4	1-8 3/4	
First Half	1-8 1/2	1-8 1/2	
First Diag.	3-5 5/8	3-5 5/8	
Depth	20.00	20.00	

Loads, *** All loads are factored ***

Load Type	Category	Load1	Load2	Position	Direction	Loc/Begin	Sp/End
Uniform (plf)	DL	198.00	198.00	TC	+	0-0	18-11 1/4
Uniform (plf)	LL	432.00	432.00	TC	+	0-0	18-11 1/4
Uniform (plf)	LL	238.00	883.00	TC	+	<0-0 1/4>	18-9 1/8
Net Uplift (plf)	WL	204.00	204.00	TC	-	0-0	18-11 1/4
Conc anywhere (lbs)	TL	315.00	0.00	BC	+	9-5 5/8	0-0
Conc anywhere (lbs)	TL	315.00	0.00	TC	+	9-5 5/8	0-0

Stress Analysis Summary

Int. Panel TC: 24.00	Max Panel BC: 48.00	Reaction LE: 10,681.99	Reaction RE: 12,700.73	Minimum Shear: 3,175.18	Max TC Comp.: 34,738.25	Max BC Tension: 33,426.25
--------------------------------	-------------------------------	----------------------------------	----------------------------------	-----------------------------------	-----------------------------------	-------------------------------------

Member	TC Tension	TC Compression	BC Tension	BC Compression	Web Tension	Web Comp.	Web Length	PP Dist.
W2	1,819.35	11,414.05	0.00	0.00	16,444.38	2,551.48	26.82	0-2
V1S	1,812.44	11,366.06	0.00	0.00	346.69	3,150.74	18.81	1-8 3/4
W3	1,812.44	11,366.06	20,977.74	3,384.72	2,133.57	13,332.65	27.82	1-9 1/8
W4	4,724.44	28,898.41	20,977.74	3,384.72	10,565.44	1,701.97	30.49	3-5 5/8
W5	4,724.44	28,898.41	33,426.25	5,528.27	1,021.18	6,947.55	30.49	5-5 5/8
W6	5,796.21	34,738.25	33,426.25	5,528.27	5,148.21	791.60	30.49	7-5 5/8

* Symmetrical Joist

Standard Verticals

Member	Position	Max Tension	Max Comp.	Length
V2	Interior	435.43	3,462.05	18.80

STRESS ANALYSIS - PAGE 2



NEW MILLENNIUM
BUILDING SYSTEMS

Job Number: 8010-0704	Job Name: 10-123 BARRHAVEN FIRE STATION - SHOPORDERS	Date Run: 11/19/2010 3:58:59 PM
Location: OTTAWA, ON	Joist Description: Short Span Crimp 20K630/288	Mark: J16

Chord Properties

Chord	Area	Rx	Rz	Ryy	Y	Ix	Q	Material
TC	0.7155	0.6489	0.3818	1.3483	0.6194	0.3013	1.0000	A36 = 2.0938 x .187
BC	0.6208	0.6001	0.3508	1.2870	0.5761	0.2235	1.0000	A34 = 1.9375 x .176

Axial and Bending Analysis

K: 1.00	Fy: 50,000.00	Fb: 45,000.00	Mom of Inertia: 235.60	LL 300: 1,640.30	TL 480: 1,025.19	Max Bridg TC: 16-3 1/2	Max Bridg BC: 23-2 3/4
-------------------	-------------------------	-------------------------	----------------------------------	----------------------------	----------------------------	----------------------------------	----------------------------------

Top Chord Check	End Panel LE	First Panel LE	Interior Panel	First Panel RE	End Panel RE	Gap Between Chords: 1.1250
Length	18.75	20.88	24.00	20.88	18.75	Min Weld Len 2X: 0.5000
Bending Load	861.46	918.70	1,191.54	1,395.05	1,452.29	Max Load Fillers TC: 54,908.13
Axial Load	9,860.54	9,830.13	34,738.25	11,366.07	11,414.05	Max Load no Fillers TC: 45,544.74
fa	6,890.59	6,869.34	24,275.25	7,942.66	7,976.19	TC OAL/Ryy: 165.5811
Maximum K L/r	49.11	54.68	62.86	54.68	49.11	BC Stress: 31,186.78
Fcr	41,916.26	40,182.69	37,453.21	40,182.69	41,916.26	BC L/Rz: 136.8117
Fa	37,724.64	36,164.42	33,707.89	36,164.42	37,724.64	TC Shear Stress: 19,765.61
F'e	342,806.19	276,565.63	209,232.27	276,565.63	342,806.19	BC Shear Stress: 23,092.30
Cm	0.9933	0.9917	0.9484	0.9904	0.9922	
Panel Point Moment	3477.48	3650.29	5466.18	5180.02	5375.28	
Mid Panel Moment	2565.03	1694.65	2973.71	2267.08	3883.85	
Panel Point fb	8509.02	8931.86	13375.14	12674.93	13152.72	
Mid Panel fb	2636.57	1741.91	3056.65	2330.31	3992.16	
Fillers	0	0	0	0	0	
Panel Point Stress	15,399.62	15,801.20	37,650.39	20,617.59	21,128.91	
Mid Panel Stress	0.1509	0.1345	0.7859	0.2667	0.2918	

Web Design

Member	Web Tension	Allow Tension	Web Comp	Allow Comp	Weld	Qty	Material
W2	16,444.38	19,546.97	2,551.48	13,077.10	4.92 x 0.150	1	C28 = 1.125 x 1.347 x .150
W3	2,133.57	25,317.00	13,332.65	14,147.43	3.67 x 0.163	1	C32 = 1.125 x 1.479 x .163
W4	10,565.44	11,869.06	1,701.97	6,302.35	4.52 x 0.105	1	C16 = 1.125 x 0.943 x .105
W5	1,021.18	13,593.73	6,947.55	7,629.28	2.71 x 0.115	1	C18 = 1.125 x 1.012 x .115
W6	5,148.21	7,215.59	791.60	2,383.82	3.01 x 0.077	1	C10 = 1.125 x 0.700 x 0.07
V1	346.69	7,215.59	3,150.74	4,571.16	2.00 x 0.077	1	C10 = 1.125 x 0.700 x 0.07
V2	435.43	7,215.59	3,462.05	4,571.89	2.00 x 0.077	1	C10 = 1.125 x 0.700 x 0.07

* Symmetrical Joist

STRESS ANALYSIS - PAGE 3



Job Number: 8010-0704	Job Name: 10-123 BARRHAVEN FIRE STATION - SHOPORDERS	Date Run: 11/19/2010 3:58:59 PM
Location: OTTAWA, ON	Joist Description: Short Span Crimp 20K630/288	Mark: J16

TCX Design

TCX Left		TCX Right	
TCX Length	0-0 1/4	TCX Length	0-1 1/2
TCX Type	R	TCX Type	R
TCX Depth	4	TCX Depth	4
BPL Length	0-4 1/4	BPL Length	0-5 1/2
Clear Bearing	0-5 1/8	Clear Bearing	0-5 3/8
BPL Material: 69L = 2 x 3 x .250		BPL Material: 69L = 2 x 3 x .250	

Total Load	630.00	Total Load	630.00
Reqd TL Def L/80	0.00	Reqd TL Def L/80	0.02
Live Load	432.00	Live Load	432.00
Reqd LL Def L/120	0.00	Reqd LL Def L/120	0.01
Section Modulus	0.4087	Section Modulus	0.4087
Reqd SM	0.0000	Reqd SM	0.0014
Mom of Inertia	0.6026	Mom of Inertia	0.6026
Reqd MI	0.0000	Reqd MI	0.0000

Seat Type: Lapped

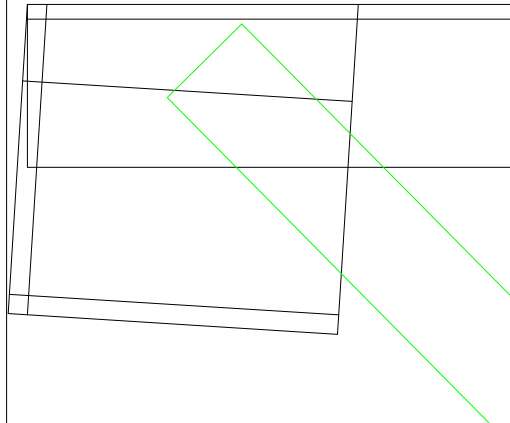

Seat Type: Lapped

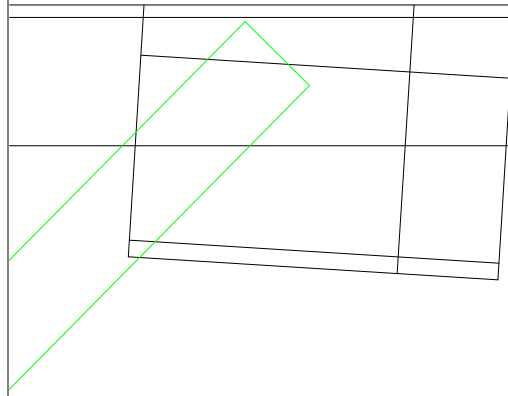

LSD Design

- | | |
|---|--|
| <ul style="list-style-type: none"> Case 1a: DL Case 1b: 1.4(DL) Case 2a: LL Case 2b: SL Case 3a: 1.25(DL+CL)+1.5(TL+LL) Case 3b: 1.25(DL+CL)+1.5(TL+SL) Case 3c: 1.25(DL+CL)+1.5(TL+LL+FEM) Case 3d: 1.25(DL+CL)+1.5(TL+SL+FEM) Case 3e: DL+CL+TL+LL Case 3f: DL+CL+TL+SL Case 4a: 1.25(DL)+0.5(CL+LL)+1.4(WL+AX)+0.8(TL) Case 4b: 1.25(DL)+0.5(CL+LL)+1.4(WL-AX)+0.8(TL) Case 4c: 1.25(DL)+0.5(CL+LL)+1.4(WL+AX+IP)+0.8(TL) Case 4d: 1.25(DL)+0.5(CL+LL)+1.4(WL-AX+IP)+0.8(TL) Case 4e: 1.25(DL+CL)+1.4(WL+AX)+1.1(TL)+LL Case 4f: 1.25(DL+CL)+1.4(WL-AX)+1.1(TL)+LL Case 5a: 0.9(DL)+1.4(WL+AX) Case 5b: 0.9(DL)+1.4(WL-AX) Case 5c: 0.9(DL)+1.4(WL+AX+IP) Case 5d: 0.9(DL)+1.4(WL-AX+IP) Case 5e: DL+SM+AX Case 5f: DL+SM-AX | <ul style="list-style-type: none"> Case 6a: 1.25(DL)+0.5(CL+SL)+1.4(WL+AX)+0.8(TL) Case 6b: 1.25(DL)+0.5(CL+SL)+1.4(WL-AX)+0.8(TL) Case 6c: 1.25(DL)+0.5(CL+SL)+1.4(WL+AX+IP)+0.8(TL) Case 6d: 1.25(DL)+0.5(CL+SL)+1.4(WL-AX+IP)+0.8(TL) Case 7a: 1.25(DL+CL)+0.4(WL+AX)+1.5(TL+LL) Case 7b: 1.25(DL+CL)+0.4(WL-AX)+1.5(TL+LL) Case 7c: 1.25(DL+CL)+0.4(WL+AX+IP)+1.5(TL+LL) Case 7d: 1.25(DL+CL)+0.4(WL-AX+IP)+1.5(TL+LL) Case 8a: 1.25(DL+CL)+0.4(WL+AX)+1.5(TL+SL) Case 8b: 1.25(DL+CL)+0.4(WL-AX)+1.5(TL+SL) Case 8c: 1.25(DL+CL)+0.4(WL+AX+IP)+1.5(TL+SL) Case 8d: 1.25(DL+CL)+0.4(WL-AX+IP)+1.5(TL+SL) Case 9a: DL+CL+0.5(LL)+0.7(TL)+SM+AX+FEM Case 9b: DL+CL+0.5(LL)+0.7(TL)+SM-AX+FEM Case 9c: DL+CL+0.25(SL)+0.7(TL)+SM+AX+FEM Case 9d: DL+CL+0.25(SL)+0.7(TL)+SM-AX+FEM Case 9e: DL+CL+LL+1.1(TL)+SM+AX+FEM Case 9f: DL+CL+LL+1.1(TL)+SM-AX+FEM Case 10a: DL+SM+AX Case 10b: DL+SM-AX Case 10c: DL+CL+SM+AX Case 10d: DL+CL+SM-AX |
|---|--|

STRESS ANALYSIS - PAGE 1



NEW MILLENNIUM
BUILDING SYSTEMS

Job Number: 8010-0704	Job Name: 10-123 BARRHAVEN FIRE STATION - SHOPORDERS	Date Run: 11/19/2010 3:59:21 PM
Location: OTTAWA, ON	Joist Description: Short Span Crimp 20K577/263	Mark: J20

Geometry

Base Length: 18-9 1/4	Working Length: 18-5 1/4	Joist Depth: 20.00	Effective Depth: 18.87	BC Panel Length: 4 @ 4-0	Shape: Parallel Chords
---------------------------------	------------------------------------	------------------------------	----------------------------------	------------------------------------	----------------------------------

Variable	Left End	Right End
BC Panel	1-8 1/8	1-8 1/8
TC Panel	1-4 5/8	1-4 5/8
First Half	1-8 1/2	1-8 1/2
First Diag.	3-4 5/8	3-4 5/8
Depth	20.00	20.00

Deflection Case 2a: LL (Max Deflection: -0.38 in-Y, -0.07 in-X)

Loads, *** All loads are factored ***

Load Type	Category	Load1	Load2	Position	Direction	Loc/Begin	Sp/End
Uniform (plf)	DL	181.50	181.50	TC	+	0-0	18-9 1/4
Uniform (plf)	LL	394.50	394.50	TC	+	0-0	18-9 1/4
Uniform (plf)	LL	238.00	883.00	TC	+	<0-2 1/4>	18-7 1/8
Net Uplift (plf)	WL	204.00	204.00	TC	-	0-0	18-9 1/4
Conc anywhere (lbs)	TL	315.00	0.00	BC	+	9-4 5/8	0-0
Conc anywhere (lbs)	TL	315.00	0.00	TC	+	9-4 5/8	0-0

Stress Analysis Summary

Int. Panel TC: 24.00	Max Panel BC: 48.00	Reaction LE: 10,093.72	Reaction RE: 12,094.96	Minimum Shear: 3,023.74	Max TC Comp.: 32,561.36	Max BC Tension: 31,316.29
--------------------------------	-------------------------------	----------------------------------	----------------------------------	-----------------------------------	-----------------------------------	-------------------------------------

Member	TC Tension	TC Compression	BC Tension	BC Compression	Web Tension	Web Comp.	Web Length	PP Dist.
W2	1,732.20	10,476.53	0.00	0.00	15,547.69	2,500.40	26.16	0-2
V1S	1,669.67	10,055.72	0.00	0.00	342.83	3,067.43	19.19	1-4 5/8
W3	1,669.67	10,055.72	19,440.33	3,262.61	2,164.94	13,056.17	27.86	1-8 1/8
W4	4,594.69	27,001.94	19,440.33	3,262.61	10,106.48	1,694.44	30.53	3-4 5/8
W5	4,594.69	27,001.94	31,316.29	5,393.94	1,016.66	6,661.13	30.53	5-4 5/8
W6	5,660.35	32,561.36	31,316.29	5,393.94	4,892.48	781.03	30.53	7-4 5/8

* Symmetrical Joist

Standard Verticals

Member	Position	Max Tension	Max Comp.	Length
V2	Interior	461.36	3,345.67	18.87

STRESS ANALYSIS - PAGE 2



NEW MILLENNIUM
BUILDING SYSTEMS

Job Number: 8010-0704	Job Name: 10-123 BARRHAVEN FIRE STATION - SHOPORDERS	Date Run: 11/19/2010 3:59:21 PM
Location: OTTAWA, ON		Joist Description: Short Span Crimp 20K577/263
		Mark: J20

Chord Properties

Chord	Area	Rx	Rz	Ryy	Y	Ix	Q	Material
TC	0.6208	0.6001	0.3508	1.2870	0.5761	0.2235	1.0000	A34 = 1.9375 x .176
BC	0.5636	0.5816	0.3394	1.2607	0.5561	0.1906	1.0000	A32 = 1.8750 x .165

Axial and Bending Analysis

K: 1.00	Fy: 50,000.00	Fb: 45,000.00	Mom of Inertia: 210.73	LL 300: 1,507.29	TL 480: 942.06	Max Bridg TC: 15-6 5/8	Max Bridg BC: 21-9 5/8
-------------------	-------------------------	-------------------------	----------------------------------	----------------------------	--------------------------	----------------------------------	----------------------------------

Top Chord Check	End Panel LE	First Panel LE	Interior Panel	First Panel RE	End Panel RE	Gap Between Chords: 1.1250
Length	14.63	24.00	24.00	24.00	14.63	Min Weld Len 2X: 0.5000
Bending Load	803.35	859.65	1,139.51	1,349.41	1,405.71	Max Load Fillers TC: 45,938.36
Axial Load	8,927.35	8,669.57	32,561.36	10,055.72	10,476.53	Max Load no Fillers TC: 36,797.23
fa	7,190.54	6,982.91	26,226.58	8,099.39	8,438.33	TC OAL/Ryy: 171.9059
Maximum K L/r	41.68	68.41	68.41	68.41	41.68	BC Stress: 32,628.46
Fcr	44,034.47	35,512.37	35,512.37	35,512.37	44,034.47	BC L/Rz: 141.4125
Fa	39,631.02	31,961.13	31,961.13	31,961.13	39,631.02	TC Shear Stress: 22,406.86
F'e	481,818.84	178,917.59	178,917.59	178,917.59	481,818.84	BC Shear Stress: 24,777.70
Cm	0.9950	0.9870	0.9349	0.9849	0.9942	
Panel Point Moment	3180.24	3509.43	5258.06	5110.03	5149.36	
Mid Panel Moment	1218.49	2547.90	2869.65	3663.00	1756.58	
Panel Point fb	9685.15	10687.68	16012.97	15562.17	15681.94	
Mid Panel fb	1570.30	3283.54	3698.20	4720.61	2263.75	
Fillers	0	0	0	0	0	
Panel Point Stress	16,875.69	17,670.60	42,239.55	23,661.56	24,120.26	
Mid Panel Stress	0.1260	0.2854	0.9022	0.3501	0.2583	

Web Design

Member	Web Tension	Allow Tension	Web Comp	Allow Comp	Weld	Qty	Material
W2	15,547.69	19,546.97	2,500.40	13,174.04	4.65 x 0.150	1	C28 = 1.125 x 1.347 x .150
W3	2,164.94	25,317.00	13,056.17	14,065.99	3.60 x 0.163	1	C32 = 1.125 x 1.479 x .163
W4	10,106.48	11,869.06	1,694.44	6,218.28	4.32 x 0.105	1	C16 = 1.125 x 0.943 x .105
W5	1,016.66	13,593.73	6,661.13	7,579.75	2.60 x 0.115	1	C18 = 1.125 x 1.012 x .115
W6	4,892.48	7,215.59	781.03	2,329.49	2.86 x 0.077	1	C10 = 1.125 x 0.700 x 0.07
V1	342.83	7,215.59	3,067.43	4,458.45	2.00 x 0.077	1	C10 = 1.125 x 0.700 x 0.07
V2	461.36	7,215.59	3,345.67	4,521.83	2.00 x 0.077	1	C10 = 1.125 x 0.700 x 0.07

* Symmetrical Joist

STRESS ANALYSIS - PAGE 3



NEW MILLENNIUM
BUILDING SYSTEMS

Job Number: 8010-0704	Job Name: 10-123 BARRHAVEN FIRE STATION - SHOPORDERS	Date Run: 11/19/2010 3:59:21 PM
Location: OTTAWA, ON	Joist Description: Short Span Crimp 20K577/263	Mark: J20

TCX Design

TCX Left		TCX Right	
TCX Length	0-2 1/4	TCX Length	0-1 1/2
TCX Type	R	TCX Type	R
TCX Depth	4	TCX Depth	4
BPL Length	0-6 1/4	BPL Length	0-5 1/2
Clear Bearing	0-7	Clear Bearing	0-5 3/4
BPL Material: 69L = 2 x 3 x .250		BPL Material: 69L = 2 x 3 x .250	

Total Load	576.00	Total Load	576.00
Reqd TL Def L/80	0.03	Reqd TL Def L/80	0.02
Live Load	394.50	Live Load	394.50
Reqd LL Def L/120	0.02	Reqd LL Def L/120	0.01
Section Modulus	0.3284	Section Modulus	0.3284
Reqd SM	0.0029	Reqd SM	0.0013
Mom of Inertia	0.4470	Mom of Inertia	0.4470
Reqd MI	0.0001	Reqd MI	0.0000

Seat Type: Lapped

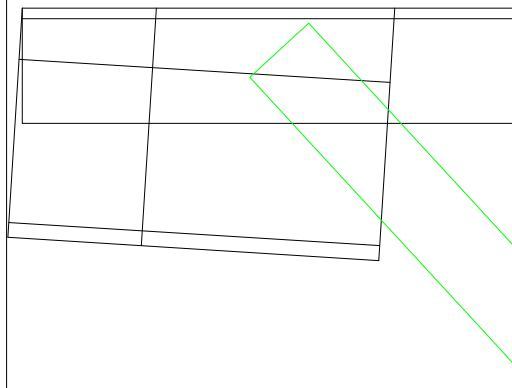

Seat Type: Lapped

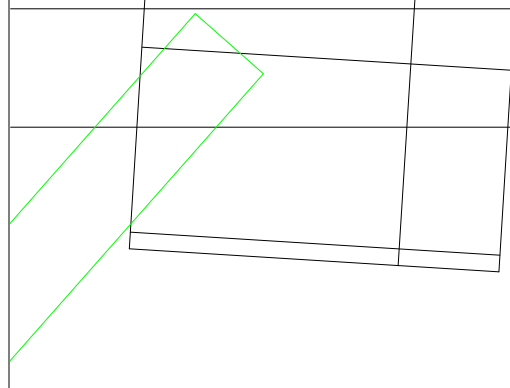

LSD Design

- | | |
|--|--|
| Case 1a: DL | Case 6a: 1.25(DL)+0.5(CL+SL)+1.4(WL+AX)+0.8(TL) |
| Case 1b: 1.4(DL) | Case 6b: 1.25(DL)+0.5(CL+SL)+1.4(WL-AX)+0.8(TL) |
| Case 2a: LL | Case 6c: 1.25(DL)+0.5(CL+SL)+1.4(WL+AX+IP)+0.8(TL) |
| Case 2b: SL | Case 6d: 1.25(DL)+0.5(CL+SL)+1.4(WL-AX+IP)+0.8(TL) |
| Case 3a: 1.25(DL+CL)+1.5(TL+LL) | Case 7a: 1.25(DL+CL)+0.4(WL+AX)+1.5(TL+LL) |
| Case 3b: 1.25(DL+CL)+1.5(TL+SL) | Case 7b: 1.25(DL+CL)+0.4(WL-AX)+1.5(TL+LL) |
| Case 3c: 1.25(DL+CL)+1.5(TL+LL+FEM) | Case 7c: 1.25(DL+CL)+0.4(WL+AX+IP)+1.5(TL+LL) |
| Case 3d: 1.25(DL+CL)+1.5(TL+SL+FEM) | Case 7d: 1.25(DL+CL)+0.4(WL-AX+IP)+1.5(TL+LL) |
| Case 3e: DL+CL+TL+LL | Case 8a: 1.25(DL+CL)+0.4(WL+AX)+1.5(TL+SL) |
| Case 3f: DL+CL+TL+SL | Case 8b: 1.25(DL+CL)+0.4(WL-AX)+1.5(TL+SL) |
| Case 4a: 1.25(DL)+0.5(CL+LL)+1.4(WL+AX)+0.8(TL) | Case 8c: 1.25(DL+CL)+0.4(WL+AX+IP)+1.5(TL+SL) |
| Case 4b: 1.25(DL)+0.5(CL+LL)+1.4(WL-AX)+0.8(TL) | Case 8d: 1.25(DL+CL)+0.4(WL-AX+IP)+1.5(TL+SL) |
| Case 4c: 1.25(DL)+0.5(CL+LL)+1.4(WL+AX+IP)+0.8(TL) | Case 9a: DL+CL+0.5(LL)+0.7(TL)+SM+AX+FEM |
| Case 4d: 1.25(DL)+0.5(CL+LL)+1.4(WL-AX+IP)+0.8(TL) | Case 9b: DL+CL+0.5(LL)+0.7(TL)+SM-AX+FEM |
| Case 4e: 1.25(DL+CL)+1.4(WL+AX)+1.1(TL)+LL | Case 9c: DL+CL+0.25(SL)+0.7(TL)+SM+AX+FEM |
| Case 4f: 1.25(DL+CL)+1.4(WL-AX)+1.1(TL)+LL | Case 9d: DL+CL+0.25(SL)+0.7(TL)+SM-AX+FEM |
| Case 5a: 0.9(DL)+1.4(WL+AX) | Case 9e: DL+CL+LL+1.1(TL)+SM+AX+FEM |
| Case 5b: 0.9(DL)+1.4(WL-AX) | Case 9f: DL+CL+LL+1.1(TL)+SM-AX+FEM |
| Case 5c: 0.9(DL)+1.4(WL+AX+IP) | Case 10a: DL+SM+AX |
| Case 5d: 0.9(DL)+1.4(WL-AX+IP) | Case 10b: DL+SM-AX |
| Case 5e: DL+SM+AX | Case 10c: DL+CL+SM+AX |
| Case 5f: DL+SM-AX | Case 10d: DL+CL+SM-AX |

STRESS ANALYSIS - PAGE 1



NEW MILLENNIUM
BUILDING SYSTEMS

Job Number: 8010-0704	Job Name: 10-123 BARRHAVEN FIRE STATION - SHOPORDERS	Date Run: 11/19/2010 3:59:35 PM
Location: OTTAWA, ON		Joist Description: Short Span Crimp 20K514/234
		Mark: J21

Geometry

Base Length: 18-9 1/4	Working Length: 18-5 1/4	Joist Depth: 20.00	Effective Depth: 18.93	BC Panel Length: 4 @ 4-0	Shape: Parallel Chords
---------------------------------	------------------------------------	------------------------------	----------------------------------	------------------------------------	----------------------------------

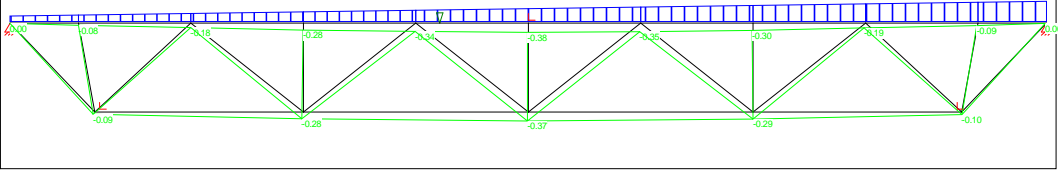
Variable	Left End	Right End	Deflection Case 2a: LL (Max Deflection: -0.38 in-Y, -0.07 in-X) 
BC Panel	1-8 1/8	1-8 1/8	
TC Panel	1-4 5/8	1-4 5/8	
First Half	1-8 1/2	1-8 1/2	
First Diag.	3-4 5/8	3-4 5/8	
Depth	20.00	20.00	

Loads, *** All loads are factored ***

Load Type	Category	Load1	Load2	Position	Direction	Loc/Begin	Sp/End
Uniform (plf)	DL	162.00	162.00	TC	+	0-0	18-9 1/4
Uniform (plf)	LL	351.00	351.00	TC	+	0-0	18-9 1/4
Uniform (plf)	LL	238.00	883.00	TC	+	<0-2 1/4>	18-7 1/8
Net Uplift (plf)	WL	204.00	204.00	TC	-	0-0	18-9 1/4
Conc Load (lbs)	TL	1,700.00	0.00	TC	+	1-9 3/4	7-9 3/4
Conc anywhere (lbs)	TL	315.00	0.00	BC	+	9-4 5/8	0-0
Conc anywhere (lbs)	TL	315.00	0.00	TC	+	9-4 5/8	0-0

Stress Analysis Summary

Int. Panel TC: 24.00	Max Panel BC: 48.00	Reaction LE: 11,048.79	Reaction RE: 12,206.71	Minimum Shear: 3,051.68	Max TC Comp.: 34,870.67	Max BC Tension: 32,944.92
--------------------------------	-------------------------------	----------------------------------	----------------------------------	-----------------------------------	-----------------------------------	-------------------------------------

Member	TC Tension	TC Compression	BC Tension	BC Compression	Web Tension	Web Comp.	Web Length	PP Dist.
W2	1,721.37	10,595.80	0.00	0.00	15,729.66	2,489.27	26.21	0-2
V1S	1,659.23	10,195.21	0.00	0.00	341.83	3,679.79	19.25	1-4 5/8
W3	1,659.23	10,195.21	19,833.06	3,242.21	2,154.84	13,402.38	27.91	1-8 1/8
W4	4,565.96	27,862.75	19,833.06	3,242.21	11,796.30	1,686.08	30.57	3-4 5/8
W5	4,565.96	27,862.75	32,944.92	5,360.21	1,145.44	7,968.32	30.57	5-4 5/8
W6	5,624.95	34,870.67	32,944.92	5,360.21	4,927.10	1,368.25	30.57	7-4 5/8

* Symmetrical Joist

Standard Verticals

Member	Position	Max Tension	Max Comp.	Length
V2	Interior	2,192.00	4,371.49	18.93

STRESS ANALYSIS - PAGE 2



NEW MILLENNIUM
BUILDING SYSTEMS

Job Number: 8010-0704	Job Name: 10-123 BARRHAVEN FIRE STATION - SHOPORDERS	Date Run: 11/19/2010 3:59:35 PM
Location: OTTAWA, ON		Joist Description: Short Span Crimp 20K514/234
		Mark: J21

Chord Properties

Chord	Area	Rx	Rz	Ryy	Y	Ix	Q	Material
TC	0.6208	0.6001	0.3508	1.2870	0.5761	0.2235	1.0000	A34 = 1.9375 x .176
BC	0.4801	0.5431	0.3457	1.1847	0.4904	0.1416	0.9538	14 = 1 3/4 x 1 3/4 x .143

Axial and Bending Analysis

K: 1.00	Fy: 50,000.00	Fb: 45,000.00	Mom of Inertia: 194.45	LL 300: 1,390.87	TL 480: 869.29	Max Bridg TC: 15-6 5/8	Max Bridg BC: 18-6 7/8
-------------------	-------------------------	-------------------------	----------------------------------	----------------------------	--------------------------	----------------------------------	----------------------------------

Top Chord Check	End Panel LE	First Panel LE	Interior Panel	First Panel RE	End Panel RE	Gap Between Chords: 1.1250
Length	14.63	24.00	24.00	24.00	14.63	Min Weld Len 2X: 0.5000
Bending Load	742.26	798.56	1,078.42	1,288.32	1,344.62	Max Load Fillers TC: 46,137.81
Axial Load	9,329.68	9,091.53	34,870.67	10,195.21	10,595.80	Max Load no Fillers TC: 36,952.11
fa	7,514.60	7,322.78	28,086.62	8,211.74	8,534.40	TC OAL/Ryy: 171.9059
Maximum K L/r	41.68	68.41	68.41	68.41	41.68	BC Stress: 40,541.06
Fcr	44,034.47	35,512.37	35,512.37	35,512.37	44,034.47	BC L/Rz: 138.8426
Fa	39,631.02	31,961.13	31,961.13	31,961.13	39,631.02	TC Shear Stress: 22,703.95
F'e	481,818.84	178,917.59	178,917.59	178,917.59	481,818.84	BC Shear Stress: 23,398.38
Cm	0.9948	0.9864	0.9302	0.9847	0.9941	
Panel Point Moment	2980.53	3309.77	5013.68	4910.37	4949.64	
Mid Panel Moment	1163.91	2408.80	2747.47	3523.90	1702.01	
Panel Point fb	9076.94	10079.63	15268.75	14954.12	15073.72	
Mid Panel fb	1499.97	3104.28	3540.73	4541.35	2193.42	
Fillers	0	0	0	0	0	
Panel Point Stress	16,591.54	17,402.42	43,355.36	23,165.86	23,608.12	
Mid Panel Stress	0.1286	0.2925	0.9576	0.3500	0.2593	

Web Design

Member	Web Tension	Allow Tension	Web Comp	Allow Comp	Weld	Qty	Material
W2	15,729.66	19,546.97	2,489.27	13,134.13	4.71 x 0.150	1	C28 = 1.125 x 1.347 x .150
W3	2,154.84	25,317.00	13,402.38	14,025.45	3.69 x 0.163	1	C32 = 1.125 x 1.479 x .163
W4	11,796.30	11,869.06	1,686.08	6,177.54	5.04 x 0.105	1	C16 = 1.125 x 0.943 x .105
W5	1,145.44	16,459.83	7,968.32	9,429.84	2.67 x 0.134	1	C22 = 1.125 x 1.086 x .134
W6	4,927.10	7,215.59	1,368.25	2,303.80	2.88 x 0.077	1	C10 = 1.125 x 0.700 x 0.07
V1	341.83	7,215.59	3,679.79	4,429.66	2.15 x 0.077	1	C10 = 1.125 x 0.700 x 0.07
V2	2,192.00	7,215.59	4,371.49	4,493.16	2.56 x 0.077	1	C10 = 1.125 x 0.700 x 0.07

* Symmetrical Joist

STRESS ANALYSIS - PAGE 3



NEW MILLENNIUM
BUILDING SYSTEMS

<i>Job Number:</i> 8010-0704	<i>Job Name:</i> 10-123 BARRHAVEN FIRE STATION - SHOPORDERS	<i>Date Run:</i> 11/19/2010 3:59:35 PM
<i>Location:</i> OTTAWA, ON	<i>Joist Description:</i> Short Span Crimp 20K514/234	<i>Mark:</i> J21

TCX Design

TCX Left		TCX Right	
TCX Length	0-2 1/4	TCX Length	0-1 1/2
TCX Type	R	TCX Type	R
TCX Depth	4	TCX Depth	4
BPL Length	0-6 1/4	BPL Length	0-5 1/2
Clear Bearing	0-6 7/8	Clear Bearing	0-5 3/4
BPL Material: 69L = 2 x 3 x .250		BPL Material: 69L = 2 x 3 x .250	
Total Load	513.00	Total Load	513.00
Reqd TL Def L/80	0.03	Reqd TL Def L/80	0.02
Live Load	351.00	Live Load	351.00
Reqd LL Def L/120	0.02	Reqd LL Def L/120	0.01
Section Modulus	0.3284	Section Modulus	0.3284
Reqd SM	0.0026	Reqd SM	0.0011
Mom of Inertia	0.4470	Mom of Inertia	0.4470
Reqd MI	0.0001	Reqd MI	0.0000
Seat Type: Lapped		Seat Type: Lapped	

LSD Design

- | | |
|---|--|
| <ul style="list-style-type: none"> Case 1a: DL Case 1b: 1.4(DL) Case 2a: LL Case 2b: SL Case 3a: 1.25(DL+CL)+1.5(TL+LL) Case 3b: 1.25(DL+CL)+1.5(TL+SL) Case 3c: 1.25(DL+CL)+1.5(TL+LL+FEM) Case 3d: 1.25(DL+CL)+1.5(TL+SL+FEM) Case 3e: DL+CL+TL+LL Case 3f: DL+CL+TL+SL Case 4a: 1.25(DL)+0.5(CL+LL)+1.4(WL+AX)+0.8(TL) Case 4b: 1.25(DL)+0.5(CL+LL)+1.4(WL-AX)+0.8(TL) Case 4c: 1.25(DL)+0.5(CL+LL)+1.4(WL+AX+IP)+0.8(TL) Case 4d: 1.25(DL)+0.5(CL+LL)+1.4(WL-AX+IP)+0.8(TL) Case 4e: 1.25(DL+CL)+1.4(WL+AX)+1.1(TL)+LL Case 4f: 1.25(DL+CL)+1.4(WL-AX)+1.1(TL)+LL Case 5a: 0.9(DL)+1.4(WL+AX) Case 5b: 0.9(DL)+1.4(WL-AX) Case 5c: 0.9(DL)+1.4(WL+AX+IP) Case 5d: 0.9(DL)+1.4(WL-AX+IP) Case 5e: DL+SM+AX Case 5f: DL+SM-AX | <ul style="list-style-type: none"> Case 6a: 1.25(DL)+0.5(CL+SL)+1.4(WL+AX)+0.8(TL) Case 6b: 1.25(DL)+0.5(CL+SL)+1.4(WL-AX)+0.8(TL) Case 6c: 1.25(DL)+0.5(CL+SL)+1.4(WL+AX+IP)+0.8(TL) Case 6d: 1.25(DL)+0.5(CL+SL)+1.4(WL-AX+IP)+0.8(TL) Case 7a: 1.25(DL+CL)+0.4(WL+AX)+1.5(TL+LL) Case 7b: 1.25(DL+CL)+0.4(WL-AX)+1.5(TL+LL) Case 7c: 1.25(DL+CL)+0.4(WL+AX+IP)+1.5(TL+LL) Case 7d: 1.25(DL+CL)+0.4(WL-AX+IP)+1.5(TL+LL) Case 8a: 1.25(DL+CL)+0.4(WL+AX)+1.5(TL+SL) Case 8b: 1.25(DL+CL)+0.4(WL-AX)+1.5(TL+SL) Case 8c: 1.25(DL+CL)+0.4(WL+AX+IP)+1.5(TL+SL) Case 8d: 1.25(DL+CL)+0.4(WL-AX+IP)+1.5(TL+SL) Case 9a: DL+CL+0.5(LL)+0.7(TL)+SM+AX+FEM Case 9b: DL+CL+0.5(LL)+0.7(TL)+SM-AX+FEM Case 9c: DL+CL+0.25(SL)+0.7(TL)+SM+AX+FEM Case 9d: DL+CL+0.25(SL)+0.7(TL)+SM-AX+FEM Case 9e: DL+CL+LL+1.1(TL)+SM+AX+FEM Case 9f: DL+CL+LL+1.1(TL)+SM-AX+FEM Case 10a: DL+SM+AX Case 10b: DL+SM-AX Case 10c: DL+CL+SM+AX Case 10d: DL+CL+SM-AX |
|---|--|

STRESS ANALYSIS - PAGE 1



NEW MILLENNIUM
BUILDING SYSTEMS

Job Number: 8010-0704	Job Name: 10-123 BARRHAVEN FIRE STATION - SHOPORDERS	Date Run: 11/19/2010 3:59:50 PM
Location: OTTAWA, ON	Joist Description: Short Span Crimp 20K650/296	Mark: J23

Geometry

Base Length: 15-2 1/8	Working Length: 14-10 1/8	Joist Depth: 20.00	Effective Depth: 19.09	BC Panel Length: 3 @ 4-0	Shape: Parallel Chords
---------------------------------	-------------------------------------	------------------------------	----------------------------------	------------------------------------	----------------------------------

Variable	Left End	Right End	Deflection Case 2a: LL (Max Deflection: -0.26 in-Y, -0.05 in-X)
BC Panel	1-8 7/8	1-8 7/8	
TC Panel	1-7 1/8	1-7 1/8	
First Half	1-10 1/4	1-10 1/8	
First Diag.	3-7 1/8	3-7	
Depth	20.00	20.00	

Loads, *** All loads are factored ***

Load Type	Category	Load1	Load2	Position	Direction	Loc/Begin	Sp/End
Uniform (plf)	DL	206.00	206.00	TC	+	0-0	15-2 1/8
Uniform (plf)	LL	444.00	444.00	TC	+	0-0	15-2 1/8
Uniform (plf)	LL	238.00	883.00	TC	+	<0-2 1/4>	18-7 1/8
Net Uplift (plf)	WL	204.00	204.00	TC	-	0-0	15-2 1/8
Conc anywhere (lbs)	TL	315.00	0.00	BC	+	7-7	0-0
Conc anywhere (lbs)	TL	315.00	0.00	TC	+	7-7	0-0

Stress Analysis Summary

Int. Panel TC: 24.00	Max Panel BC: 48.00	Reaction LE: 8,788.42	Reaction RE: 10,407.90	Minimum Shear: 2,601.98	Max TC Comp.: 20,969.73	Max BC Tension 22,232.48
--------------------------------	-------------------------------	---------------------------------	----------------------------------	-----------------------------------	-----------------------------------	------------------------------------

Member	TC Tension	TC Compression	BC Tension	BC Compression	Web Tension	Web Comp.	Web Length	PP Dist.
W2	1,394.24	8,920.25	0.00	0.00	13,114.41	1,982.90	26.84	0-2
V1S	1,361.33	8,690.82	0.00	0.00	361.66	3,186.15	19.17	1-7 1/8
W3	1,361.33	8,690.82	16,246.30	2,584.95	1,612.33	10,232.01	29.32	1-8 7/8
W4	3,376.39	20,969.73	16,246.30	2,584.95	6,896.10	1,014.74	30.66	3-7 1/8
W5	3,376.39	20,969.73	22,232.48	3,639.28	626.52	4,180.15	30.66	5-7 1/8

* Symmetrical Joist

Standard Verticals

Member	Position	Max Tension	Max Comp.	Length
V2	Interior	422.86	3,330.11	19.09

STRESS ANALYSIS - PAGE 2



NEW MILLENNIUM
BUILDING SYSTEMS

Job Number: 8010-0704	Job Name: 10-123 BARRHAVEN FIRE STATION - SHOPORDERS	Date Run: 11/19/2010 3:59:50 PM
Location: OTTAWA, ON	Joist Description: Short Span Crimp 20K650/296	Mark: J23

Chord Properties

Chord	Area	Rx	Rz	Ryy	Y	Ix	Q	Material
TC	0.5185	0.5414	0.3450	1.1878	0.4947	0.1520	0.9837	15 = 1 3/4 x 1 3/4 x .155
BC	0.3318	0.4666	0.2968	1.0855	0.4176	0.0722	0.9284	08 = 1 1/2 x 1 1/2 x .115

Axial and Bending Analysis

K: 1.00	Fy: 50,000.00	Fb: 45,000.00	Mom of Inertia: 147.65	LL 300: 2,023.83	TL 480: 1,264.89	Max Bridg TC: 14-4 1/4	Max Bridg BC: 16-0 3/4
-------------------	-------------------------	-------------------------	----------------------------------	----------------------------	----------------------------	----------------------------------	----------------------------------

Top Chord Check	End Panel LE	First Panel LE	Interior Panel	First Panel RE	End Panel RE	Gap Between Chords: 1.1250
Length	17.13	24.00	24.00	23.88	17.13	Min Weld Len 2X: 0.5000
Bending Load	884.96	959.42	1,307.04	1,393.72	1,467.95	Max Load Fillers TC: 35,061.61
Axial Load	7,762.61	7,612.38	20,969.73	8,690.82	8,920.25	Max Load no Fillers TC: 28,670.60
fa	7,486.00	7,341.13	20,222.51	8,381.14	8,602.39	TC OAL/Ryy: 149.9625
Maximum K L/r	49.63	69.56	69.56	69.19	49.63	BC Stress: 43,995.31
Fcr	41,199.27	34,730.10	34,730.10	34,855.89	41,199.27	BC L/Rz: 161.7370
Fa	37,079.34	31,257.09	31,257.09	31,370.30	37,079.34	TC Shear Stress: 17,754.88
F'e	286,087.97	145,659.31	145,659.31	147,188.55	286,087.97	BC Shear Stress: 27,908.10
Cm	0.9913	0.9832	0.9383	0.9810	0.9900	
Panel Point Moment	3811.72	4128.05	5928.17	5638.04	5849.69	
Mid Panel Moment	1939.73	2662.32	3204.71	3552.07	2847.41	
Panel Point fb	15741.20	17047.54	24481.49	23283.35	24157.38	
Mid Panel fb	3157.09	4333.16	5215.95	5781.31	4634.41	
Fillers	0	0	0	0	0	
Panel Point Stress	23,227.20	24,388.67	44,704.00	31,664.48	32,759.78	
Mid Panel Stress	0.2666	0.3255	0.7632	0.3887	0.3273	

Web Design

Member	Web Tension	Allow Tension	Web Comp	Allow Comp	Weld	Qty	Material
W2	13,114.41	14,813.85	1,982.90	10,183.82	4.39 x 0.134	1	C22 = 1.125 x 1.086 x .134
W3	1,612.33	21,718.85	10,232.01	11,765.73	3.30 x 0.150	1	C28 = 1.125 x 1.347 x .150
W4	6,896.10	7,215.59	1,014.74	2,206.91	4.04 x 0.077	1	C10 = 1.125 x 0.700 x 0.07
W5	626.52	11,869.06	4,180.15	6,018.03	2.00 x 0.105	1	C16 = 1.125 x 0.943 x .105
V1	361.66	7,215.59	3,186.15	4,376.39	2.00 x 0.077	1	C10 = 1.125 x 0.700 x 0.07
V2	422.86	7,215.59	3,330.11	4,392.57	2.00 x 0.077	1	C10 = 1.125 x 0.700 x 0.07

* Symmetrical Joist

STRESS ANALYSIS - PAGE 3



NEW MILLENNIUM
BUILDING SYSTEMS

Job Number: 8010-0704	Job Name: 10-123 BARRHAVEN FIRE STATION - SHOPORDERS	Date Run: 11/19/2010 3:59:50 PM
Location: OTTAWA, ON	Joist Description: Short Span Crimp 20K650/296	Mark: J23

TCX Design

TCX Left		TCX Right	
TCX Length	0-2 1/4	TCX Length	0-0
TCX Type	R	TCX Type	R
TCX Depth	4	TCX Depth	4
BPL Length	0-6 1/4	BPL Length	0-4
Clear Bearing	0-7 1/4	Clear Bearing	0-4
BPL Material: 69L = 2 x 3 x .250		BPL Material: 69L = 2 x 3 x .250	
Total Load	650.00	Total Load	650.00
Reqd TL Def L/80	0.03	Reqd TL Def L/80	0.00
Live Load	444.00	Live Load	444.00
Reqd LL Def L/120	0.02	Reqd LL Def L/120	0.00
Section Modulus	0.2421	Section Modulus	0.0000
Reqd SM	0.0032	Reqd SM	0.0000
Mom of Inertia	0.3040	Mom of Inertia	0.0000
Reqd MI	0.0002	Reqd MI	0.0000
Seat Type: Lapped		Seat Type: Lapped	

LSD Design

- | | |
|--|--|
| Case 1a: DL | Case 6a: 1.25(DL)+0.5(CL+SL)+1.4(WL+AX)+0.8(TL) |
| Case 1b: 1.4(DL) | Case 6b: 1.25(DL)+0.5(CL+SL)+1.4(WL-AX)+0.8(TL) |
| Case 2a: LL | Case 6c: 1.25(DL)+0.5(CL+SL)+1.4(WL+AX+IP)+0.8(TL) |
| Case 2b: SL | Case 6d: 1.25(DL)+0.5(CL+SL)+1.4(WL-AX+IP)+0.8(TL) |
| Case 3a: 1.25(DL+CL)+1.5(TL+LL) | Case 7a: 1.25(DL+CL)+0.4(WL+AX)+1.5(TL+LL) |
| Case 3b: 1.25(DL+CL)+1.5(TL+SL) | Case 7b: 1.25(DL+CL)+0.4(WL-AX)+1.5(TL+LL) |
| Case 3c: 1.25(DL+CL)+1.5(TL+LL+FEM) | Case 7c: 1.25(DL+CL)+0.4(WL+AX+IP)+1.5(TL+LL) |
| Case 3d: 1.25(DL+CL)+1.5(TL+SL+FEM) | Case 7d: 1.25(DL+CL)+0.4(WL-AX+IP)+1.5(TL+LL) |
| Case 3e: DL+CL+TL+LL | Case 8a: 1.25(DL+CL)+0.4(WL+AX)+1.5(TL+SL) |
| Case 3f: DL+CL+TL+SL | Case 8b: 1.25(DL+CL)+0.4(WL-AX)+1.5(TL+SL) |
| Case 4a: 1.25(DL)+0.5(CL+LL)+1.4(WL+AX)+0.8(TL) | Case 8c: 1.25(DL+CL)+0.4(WL+AX+IP)+1.5(TL+SL) |
| Case 4b: 1.25(DL)+0.5(CL+LL)+1.4(WL-AX)+0.8(TL) | Case 8d: 1.25(DL+CL)+0.4(WL-AX+IP)+1.5(TL+SL) |
| Case 4c: 1.25(DL)+0.5(CL+LL)+1.4(WL+AX+IP)+0.8(TL) | Case 9a: DL+CL+0.5(LL)+0.7(TL)+SM+AX+FEM |
| Case 4d: 1.25(DL)+0.5(CL+LL)+1.4(WL-AX+IP)+0.8(TL) | Case 9b: DL+CL+0.5(LL)+0.7(TL)+SM-AX+FEM |
| Case 4e: 1.25(DL+CL)+1.4(WL+AX)+1.1(TL)+LL | Case 9c: DL+CL+0.25(SL)+0.7(TL)+SM+AX+FEM |
| Case 4f: 1.25(DL+CL)+1.4(WL-AX)+1.1(TL)+LL | Case 9d: DL+CL+0.25(SL)+0.7(TL)+SM-AX+FEM |
| Case 5a: 0.9(DL)+1.4(WL+AX) | Case 9e: DL+CL+LL+1.1(TL)+SM+AX+FEM |
| Case 5b: 0.9(DL)+1.4(WL-AX) | Case 9f: DL+CL+LL+1.1(TL)+SM-AX+FEM |
| Case 5c: 0.9(DL)+1.4(WL+AX+IP) | Case 10a: DL+SM+AX |
| Case 5d: 0.9(DL)+1.4(WL-AX+IP) | Case 10b: DL+SM-AX |
| Case 5e: DL+SM+AX | Case 10c: DL+CL+SM+AX |
| Case 5f: DL+SM-AX | Case 10d: DL+CL+SM-AX |

STRESS ANALYSIS - PAGE 1



NEW MILLENNIUM
BUILDING SYSTEMS

Job Number: 8010-0704	Job Name: 10-123 BARRHAVEN FIRE STATION - SHOPORDERS	Date Run: 11/19/2010 4:06:42 PM
Location: OTTAWA, ON	Joist Description: Short Span Crimp 24K573/261	Mark: J24

Geometry

Base Length: 26-11 3/4	Working Length: 26-7 3/4	Joist Depth: 24.00	Effective Depth: 23.08	BC Panel Length: 6 @ 4-0	Shape: Parallel Chords
----------------------------------	------------------------------------	------------------------------	----------------------------------	------------------------------------	----------------------------------

Variable	Left End	Right End
BC Panel	2-0 7/8	2-0 7/8
TC Panel	1-8 7/8	1-8 7/8
First Half	1-5	1-5
First Diag.	3-5 7/8	3-5 7/8
Depth	24.00	24.00

Deflection Case 2a: LL (Max Deflection: -0.52 in-Y, -0.10 in-X)

Loads, *** All loads are factored ***

Load Type	Category	Load1	Load2	Position	Direction	Loc/Begin	Sp/End
Uniform (plf)	DL	181.50	181.50	TC	+	0-0	26-11 3/4
Uniform (plf)	LL	391.50	391.50	TC	+	0-0	26-11 3/4
Net Uplift (plf)	WL	221.00	221.00	TC	-	0-0	26-11 3/4
Conc anywhere (lbs)	TL	315.00	0.00	BC	+	13-5 7/8	0-0
Conc anywhere (lbs)	TL	315.00	0.00	TC	+	13-5 7/8	0-0

Stress Analysis Summary

Int. Panel TC: 24.00	Max Panel BC: 48.00	Reaction LE: 8,252.14	Reaction RE: 8,258.09	Minimum Shear: 2,064.52	Max TC Comp.: 28,625.46	Max BC Tension: 27,701.97
--------------------------------	-------------------------------	---------------------------------	---------------------------------	-----------------------------------	-----------------------------------	-------------------------------------

Member	TC Tension	TC Compression	BC Tension	BC Compression	Web Tension	Web Comp.	Web Length	PP Dist.
W2	2,813.90	7,432.57	0.00	0.00	10,984.68	3,997.11	32.49	0-2
V1S	2,748.69	7,267.56	0.00	0.00	381.84	1,700.47	23.42	1-8 7/8
W3	2,748.69	7,267.56	12,089.92	4,562.75	3,058.62	8,411.33	28.66	2-0 7/8
W4	6,682.21	17,780.64	12,089.92	4,562.75	8,220.60	2,940.34	33.30	3-5 7/8
W5	6,682.21	17,780.64	22,279.56	8,330.69	2,286.93	6,438.58	33.30	5-5 7/8
W6	9,508.17	25,586.67	22,279.56	8,330.69	4,785.18	1,633.52	33.30	7-5 7/8
W7	9,508.17	25,586.67	27,701.97	10,214.66	1,088.16	2,994.59	33.30	9-5 7/8
W8	10,450.15	28,625.46	27,701.97	10,214.66	2,978.60	1,088.16	33.30	11-5 7/8
W8	10,450.15	28,625.46	27,701.97	10,214.66	2,978.60	1,088.16	33.30	13-5 7/8
W7	9,508.17	25,586.67	27,701.97	10,214.66	1,088.16	3,003.16	33.30	15-5 7/8
W6	9,508.17	25,586.67	22,279.56	8,330.69	4,793.76	1,633.52	33.30	17-5 7/8
W5	6,682.21	17,780.65	22,279.56	8,330.69	2,286.93	6,447.15	33.30	19-5 7/8
W4	6,682.21	17,780.65	12,089.92	4,562.75	8,229.17	2,940.34	33.30	21-5 7/8
W3	2,748.69	7,267.56	12,089.92	4,562.75	3,058.62	8,418.71	28.66	23-5 7/8
V1S	2,748.69	7,267.56	0.00	0.00	381.84	1,706.51	23.42	25-2 7/8
W2	2,813.90	7,432.57	0.00	0.00	10,993.05	3,997.11	32.49	24-10 7/8

Standard Verticals

Member	Position	Max Tension	Max Comp.	Length
V2	Interior	471.07	1,919.13	23.08

STRESS ANALYSIS - PAGE 2



Job Number: 8010-0704	Job Name: 10-123 BARRHAVEN FIRE STATION - SHOPORDERS	Date Run: 11/19/2010 4:06:42 PM
Location: OTTAWA, ON	Joist Description: Short Span Crimp 24K573/261	Mark: J24

Chord Properties

Chord	Area	Rx	Rz	Ryy	Y	Ix	Q	Material
TC	0.4410	0.4610	0.2946	1.0962	0.4321	0.0937	1.0000	12 = 1 1/2 x 1 1/2 x .155
BC	0.4801	0.5431	0.3457	1.1847	0.4904	0.1416	0.9538	14 = 1 3/4 x 1 3/4 x .143

Axial and Bending Analysis

K: 1.00	Fy: 50,000.00	Fb: 45,000.00	Mom of Inertia: 245.05	LL 300: 580.70	TL 324: 537.68	Max Bridg TC: 13-3	Max Bridg BC: 13-3 7/8
-------------------	-------------------------	-------------------------	----------------------------------	--------------------------	--------------------------	------------------------------	----------------------------------

Top Chord Check	End Panel LE	First Panel LE	Interior Panel	First Panel RE	End Panel RE	Gap Between Chords: 1.1250
Length	18.88	21.00	24.00	21.00	18.88	Min Weld Len 2X: 0.5000
Bending Load	556.09	0.00	0.00	0.00	556.09	Max Load Fillers TC: 31,906.69
Axial Load	7,432.57	7,267.56	28,625.46	7,267.56	7,432.57	Max Load no Fillers TC: 24,023.39
fa	8,427.43	8,240.33	32,457.01	8,240.33	8,427.43	TC OAL/Ryy: 291.6838
Maximum K L/r	64.06	71.27	52.06	71.27	64.06	BC Stress: 35,080.23
Fcr	37,038.68	34,487.47	41,011.91	34,487.47	37,038.68	BC L/Rz: 138.8426
Fa	33,334.81	31,038.72	36,910.72	31,038.72	33,334.81	TC Shear Stress: 17,353.97
F'e	170,745.53	137,938.25	105,608.96	137,938.25	170,745.53	BC Shear Stress: 16,111.52
Cm	0.9835	0.9801	0.8634	0.9801	0.9835	
Panel Point Moment	2528.29	700.00	700.00	700.00	2528.29	
Mid Panel Moment	1903.11	590.63	590.63	590.63	1903.11	
Panel Point fb	14404.57	3988.15	3988.15	3988.15	14404.57	
Mid Panel fb	4386.79	1361.43	1361.43	1361.43	4386.79	
Fillers	0	0	6	0	0	
Panel Point Stress	22,832.00	12,228.48	36,445.16	12,228.48	22,832.00	
Mid Panel Stress	0.3430	0.2937	0.9146	0.2937	0.3430	

Web Design

Member	Web Tension	Allow Tension	Web Comp	Allow Comp	Weld	Qty	Material
W2	10,984.68	12,234.36	3,997.11	7,211.06	4.29 x 0.115	1	C18 = 1.125 x 1.012 x .115
W3	3,058.62	21,718.85	8,411.33	11,753.98	2.52 x 0.150	1	C28 = 1.125 x 1.347 x .150
W4	8,220.60	11,869.06	2,940.34	5,190.91	3.51 x 0.105	1	C16 = 1.125 x 0.943 x .105
W5	2,286.93	13,593.73	6,438.58	6,556.56	2.51 x 0.115	1	C18 = 1.125 x 1.012 x .115
W6	4,785.18	7,215.59	1,633.52	1,783.08	2.80 x 0.077	1	C10 = 1.125 x 0.700 x 0.07
W7	1,088.16	11,869.06	2,994.59	5,190.91	2.00 x 0.105	1	C16 = 1.125 x 0.943 x .105
W8	2,978.60	7,215.59	1,088.16	1,783.08	2.00 x 0.077	1	C10 = 1.125 x 0.700 x 0.07
W8	2,978.60	7,215.59	1,088.16	1,783.08	2.00 x 0.077	1	C10 = 1.125 x 0.700 x 0.07
W7	1,088.16	11,869.06	3,003.16	5,190.91	2.00 x 0.105	1	C16 = 1.125 x 0.943 x .105
W6	4,793.76	7,215.59	1,633.52	1,783.08	2.81 x 0.077	1	C10 = 1.125 x 0.700 x 0.07
W5	2,286.93	13,593.73	6,447.15	6,556.56	2.52 x 0.115	1	C18 = 1.125 x 1.012 x .115
W4	8,229.17	11,869.06	2,940.34	5,190.91	3.52 x 0.105	1	C16 = 1.125 x 0.943 x .105
W3	3,058.62	21,718.85	8,418.71	11,753.98	2.52 x 0.150	1	C28 = 1.125 x 1.347 x .150
W2	10,993.05	12,234.36	3,997.11	7,211.06	4.29 x 0.115	1	C18 = 1.125 x 1.012 x .115
V1	381.84	7,215.59	1,706.51	3,403.72	2.00 x 0.077	1	C10 = 1.125 x 0.700 x 0.07
V2	471.07	7,215.59	1,919.13	3,473.34	2.00 x 0.077	1	C10 = 1.125 x 0.700 x 0.07

STRESS ANALYSIS - PAGE 3



NEW MILLENNIUM
BUILDING SYSTEMS

<i>Job Number:</i> 8010-0704	<i>Job Name:</i> 10-123 BARRHAVEN FIRE STATION - SHOPORDERS	<i>Date Run:</i> 11/19/2010 4:06:42 PM
<i>Location:</i> OTTAWA, ON	<i>Joist Description:</i> Short Span Crimp 24K573/261	<i>Mark:</i> J24

TCX Design

TCX Left		TCX Right	
TCX Length	0-2	TCX Length	0-1 1/2
TCX Type	R	TCX Type	R
TCX Depth	4	TCX Depth	4
BPL Length	0-6	BPL Length	0-5 1/2
Clear Bearing	0-6 5/8	Clear Bearing	0-6 1/8
BPL Material: 69L = 2 x 3 x .250		BPL Material: 69L = 2 x 3 x .250	
Total Load	573.00	Total Load	573.00
Reqd TL Def L/80	0.03	Reqd TL Def L/80	0.02
Live Load	391.50	Live Load	391.50
Reqd LL Def L/120	0.02	Reqd LL Def L/120	0.01
Section Modulus	0.1755	Section Modulus	0.1755
Reqd SM	0.0023	Reqd SM	0.0013
Mom of Inertia	0.1874	Mom of Inertia	0.1874
Reqd MI	0.0001	Reqd MI	0.0000
Seat Type: Lapped		Seat Type: Lapped	

LSD Design

- | | |
|--|--|
| Case 1a: DL | Case 6a: 1.25(DL)+0.5(CL+SL)+1.4(WL+AX)+0.8(TL) |
| Case 1b: 1.4(DL) | Case 6b: 1.25(DL)+0.5(CL+SL)+1.4(WL-AX)+0.8(TL) |
| Case 2a: LL | Case 6c: 1.25(DL)+0.5(CL+SL)+1.4(WL+AX+IP)+0.8(TL) |
| Case 2b: SL | Case 6d: 1.25(DL)+0.5(CL+SL)+1.4(WL-AX+IP)+0.8(TL) |
| Case 3a: 1.25(DL+CL)+1.5(TL+LL) | Case 7a: 1.25(DL+CL)+0.4(WL+AX)+1.5(TL+LL) |
| Case 3b: 1.25(DL+CL)+1.5(TL+SL) | Case 7b: 1.25(DL+CL)+0.4(WL-AX)+1.5(TL+LL) |
| Case 3c: 1.25(DL+CL)+1.5(TL+LL+FEM) | Case 7c: 1.25(DL+CL)+0.4(WL+AX+IP)+1.5(TL+LL) |
| Case 3d: 1.25(DL+CL)+1.5(TL+SL+FEM) | Case 7d: 1.25(DL+CL)+0.4(WL-AX+IP)+1.5(TL+LL) |
| Case 3e: DL+CL+TL+LL | Case 8a: 1.25(DL+CL)+0.4(WL+AX)+1.5(TL+SL) |
| Case 3f: DL+CL+TL+SL | Case 8b: 1.25(DL+CL)+0.4(WL-AX)+1.5(TL+SL) |
| Case 4a: 1.25(DL)+0.5(CL+LL)+1.4(WL+AX)+0.8(TL) | Case 8c: 1.25(DL+CL)+0.4(WL+AX+IP)+1.5(TL+SL) |
| Case 4b: 1.25(DL)+0.5(CL+LL)+1.4(WL-AX)+0.8(TL) | Case 8d: 1.25(DL+CL)+0.4(WL-AX+IP)+1.5(TL+SL) |
| Case 4c: 1.25(DL)+0.5(CL+LL)+1.4(WL+AX+IP)+0.8(TL) | Case 9a: DL+CL+0.5(LL)+0.7(TL)+SM+AX+FEM |
| Case 4d: 1.25(DL)+0.5(CL+LL)+1.4(WL-AX+IP)+0.8(TL) | Case 9b: DL+CL+0.5(LL)+0.7(TL)+SM-AX+FEM |
| Case 4e: 1.25(DL+CL)+1.4(WL+AX)+1.1(TL)+LL | Case 9c: DL+CL+0.25(SL)+0.7(TL)+SM+AX+FEM |
| Case 4f: 1.25(DL+CL)+1.4(WL-AX)+1.1(TL)+LL | Case 9d: DL+CL+0.25(SL)+0.7(TL)+SM-AX+FEM |
| Case 5a: 0.9(DL)+1.4(WL+AX) | Case 9e: DL+CL+LL+1.1(TL)+SM+AX+FEM |
| Case 5b: 0.9(DL)+1.4(WL-AX) | Case 9f: DL+CL+LL+1.1(TL)+SM-AX+FEM |
| Case 5c: 0.9(DL)+1.4(WL+AX+IP) | Case 10a: DL+SM+AX |
| Case 5d: 0.9(DL)+1.4(WL-AX+IP) | Case 10b: DL+SM-AX |
| Case 5e: DL+SM+AX | Case 10c: DL+CL+SM+AX |
| Case 5f: DL+SM-AX | Case 10d: DL+CL+SM-AX |

STRESS ANALYSIS - PAGE 1



NEW MILLENNIUM
BUILDING SYSTEMS

Job Number: 8010-0704	Job Name: 10-123 BARRHAVEN FIRE STATION - SHOPORDERS	Date Run: 11/19/2010 4:08:45 PM
Location: OTTAWA, ON	Joist Description: Short Span Crimp 23K704/321	Mark: J26

Geometry

Base Length: 26-11 3/4	Working Length: 26-7 3/4	Joist Depth: 23.00	Effective Depth: 22.01	BC Panel Length: 6 @ 4-0	Shape: Double Pitch with Ridge @ 13-5 7/8
----------------------------------	------------------------------------	------------------------------	----------------------------------	------------------------------------	---

Variable	Left End	Right End	Deflection Case 2a: LL (Max Deflection: -0.63 in-Y, -0.12 in-X)
BC Panel	1-11 1/8	1-11 1/8	
TC Panel	1-8 7/8	1-8 7/8	
First Half	1-6 3/4	1-6 3/4	
First Diag.	3-5 7/8	3-5 7/8	
Depth	24.00	24.00	

Loads, *** All loads are factored ***

Load Type	Category	Load1	Load2	Position	Direction	Loc/Begin	Sp/End
Uniform (plf)	DL	222.50	222.50	TC	+	0-0	26-11 3/4
Uniform (plf)	LL	481.50	481.50	TC	+	0-0	26-11 3/4
Net Uplift (plf)	WL	221.00	221.00	TC	-	0-0	26-11 3/4
Conc anywhere (lbs)	TL	315.00	0.00	BC	+	13-5 7/8	0-0
Conc anywhere (lbs)	TL	315.00	0.00	TC	+	13-5 7/8	0-0

Stress Analysis Summary

Int. Panel TC: 24.00	Max Panel BC: 48.00	Reaction LE: 9,997.45	Reaction RE: 10,003.39	Minimum Shear: 2,500.85	Max TC Comp.: 36,345.20	Max BC Tension: 34,997.93
--------------------------------	-------------------------------	---------------------------------	----------------------------------	-----------------------------------	-----------------------------------	-------------------------------------

Member	TC Tension	TC Compression	BC Tension	BC Compression	Web Tension	Web Comp.	Web Length	PP Dist.
W2	2,636.27	8,442.63	0.00	0.00	12,892.81	3,897.38	31.23	0-2
V1S	2,599.06	8,327.56	0.00	0.00	380.33	1,943.19	23.00	1-8 7/8
W3	2,599.06	8,327.56	14,937.50	4,652.31	3,228.97	10,683.39	29.49	1-11 1/8
W4	6,858.20	22,096.40	14,937.50	4,652.31	10,187.61	3,039.65	33.07	3-5 7/8
W5	6,858.20	22,096.40	27,844.41	8,606.36	2,394.44	8,062.80	32.87	5-5 7/8
W6	9,888.27	32,155.30	27,844.41	8,606.36	6,091.25	1,755.42	32.87	7-5 7/8
V3	9,888.27	32,155.30	27,844.41	8,606.36	455.35	1,993.88	22.31	9-5 7/8
W7	9,888.27	32,155.30	34,997.93	10,693.86	1,114.03	3,915.34	32.67	9-5 7/8
W8	11,014.29	36,345.20	34,997.93	10,693.86	3,698.59	1,121.51	32.67	11-5 7/8
V4	11,014.29	36,345.20	34,997.93	10,693.86	591.43	2,640.51	22.01	13-5 7/8
W8	11,014.29	36,345.20	34,997.93	10,693.86	3,698.59	1,121.51	32.67	13-5 7/8
W7	9,888.27	32,155.30	34,997.93	10,693.86	1,114.03	3,924.07	32.67	15-5 7/8
V5	9,888.27	32,155.30	34,997.93	10,693.86	455.35	1,803.69	22.31	17-5 7/8
W6	9,888.27	32,155.30	27,844.41	8,606.36	6,099.97	1,755.42	32.87	17-5 7/8
W5	6,858.19	22,096.41	27,844.41	8,606.36	2,394.44	8,071.47	32.87	19-5 7/8
V6	6,858.19	22,096.41	27,844.41	8,606.36	455.35	1,714.54	22.61	21-5 7/8
W4	6,858.19	22,096.41	14,937.50	4,652.31	10,196.28	3,039.65	33.07	21-5 7/8
W3	2,599.06	8,327.56	14,937.50	4,652.31	3,228.97	10,691.07	29.49	23-5 7/8
V1S	2,599.06	8,327.56	0.00	0.00	380.33	1,949.16	23.00	25-2 7/8
W2	2,636.27	8,442.63	0.00	0.00	12,900.90	3,897.38	31.23	25-0 5/8

Standard Verticals

Member	Position	Max Tension	Max Comp.	Length
V2	Interior	591.43	2,640.51	22.61

STRESS ANALYSIS - PAGE 2



NEW MILLENNIUM
BUILDING SYSTEMS

Job Number: 8010-0704	Job Name: 10-123 BARRHAVEN FIRE STATION - SHOPORDERS	Date Run: 11/19/2010 4:08:45 PM
Location: OTTAWA, ON		Joist Description: Short Span Crimp 23K704/321
		Mark: J26

Chord Properties

Chord	Area	Rx	Rz	Ryy	Y	Ix	Q	Material
TC	0.5185	0.5414	0.3450	1.1878	0.4947	0.1520	0.9837	15 = 1 3/4 x 1 3/4 x .155
BC	0.4801	0.5431	0.3457	1.1847	0.4904	0.1416	0.9538	14 = 1 3/4 x 1 3/4 x .143

Axial and Bending Analysis

K: 1.00	Fy: 50,000.00	Fb: 45,000.00	Mom of Inertia: 241.91	LL 360: 477.70	LL 240: 716.56	Max Bridg TC: 14-4 1/4	Max Bridg BC: 13-0
-------------------	-------------------------	-------------------------	----------------------------------	--------------------------	--------------------------	----------------------------------	------------------------------

Top Chord Check	End Panel LE	First Panel LE	Interior Panel	First Panel RE	End Panel RE	
Length	18.88	21.00	24.00	21.00	18.88	Gap Between Chords: 1.1250
Bending Load	683.16	0.00	0.00	0.00	683.16	Min Weld Len 2X: 0.5000
Axial Load	8,442.63	8,327.56	36,345.20	8,327.56	8,442.63	Max Load Fillers TC: 39,595.42
fa	8,141.79	8,030.82	35,050.10	8,030.82	8,141.79	Max Load no Fillers TC: 32,237.88
Maximum K L/r	54.70	60.86	44.33	60.86	54.70	TC OAL/Ryy: 269.1959
Fcr	39,660.31	37,681.03	42,702.52	37,681.03	39,660.31	BC Stress: 42,679.39
Fa	35,694.28	33,912.93	38,432.27	33,912.93	35,694.28	BC L/Rz: 138.8426
F'e	235,488.80	190,241.66	145,653.75	190,241.66	235,488.80	TC Shear Stress: 17,922.99
Cm	0.9885	0.9859	0.8930	0.9859	0.9885	BC Shear Stress: 19,521.06
Panel Point Moment	2942.70	700.01	700.01	700.01	2942.70	
Mid Panel Moment	2190.34	590.64	590.64	590.64	2190.34	
Panel Point fb	12152.45	2890.84	2890.84	2890.84	12152.45	
Mid Panel fb	3564.97	961.31	961.31	961.31	3564.97	
Fillers	0	0	6	0	0	
Panel Point Stress	20,294.24	10,921.66	37,940.94	10,921.66	20,294.24	
Mid Panel Stress	0.3017	0.2568	0.9355	0.2568	0.3017	

Web Design

Member	Web Tension	Allow Tension	Web Comp	Allow Comp	Weld	Qty	Material
W2	12,892.81	14,813.85	3,897.38	9,256.19	4.32 x 0.134	1	C22 = 1.125 x 1.086 x .134
W3	3,228.97	21,718.85	10,683.39	11,640.02	3.20 x 0.150	1	C28 = 1.125 x 1.347 x .150
W4	10,187.61	11,869.06	3,039.65	5,330.09	4.36 x 0.105	1	C16 = 1.125 x 0.943 x .105
W5	2,394.44	16,459.83	8,062.80	8,837.18	2.70 x 0.134	1	C22 = 1.125 x 1.086 x .134
W6	6,091.25	7,215.59	1,755.42	1,875.60	3.57 x 0.077	1	C10 = 1.125 x 0.700 x 0.07
W7	1,114.03	11,869.06	3,915.34	5,453.66	2.00 x 0.105	1	C16 = 1.125 x 0.943 x .105
W8	3,698.59	7,215.59	1,121.51	1,905.28	2.16 x 0.077	1	C10 = 1.125 x 0.700 x 0.07
W8	3,698.59	7,215.59	1,121.51	1,905.28	2.16 x 0.077	1	C10 = 1.125 x 0.700 x 0.07
W7	1,114.03	11,869.06	3,924.07	5,453.66	2.00 x 0.105	1	C16 = 1.125 x 0.943 x .105
W6	6,099.97	7,215.59	1,755.42	1,875.60	3.57 x 0.077	1	C10 = 1.125 x 0.700 x 0.07
W5	2,394.44	16,459.83	8,071.47	8,837.18	2.70 x 0.134	1	C22 = 1.125 x 1.086 x .134
W4	10,196.28	11,869.06	3,039.65	5,330.09	4.36 x 0.105	1	C16 = 1.125 x 0.943 x .105
W3	3,228.97	21,718.85	10,691.07	11,640.02	3.20 x 0.150	1	C28 = 1.125 x 1.347 x .150
W2	12,900.90	14,813.85	3,897.38	9,256.19	4.32 x 0.134	1	C22 = 1.125 x 1.086 x .134
V1	380.33	7,215.59	1,949.16	3,536.83	2.00 x 0.077	1	C10 = 1.125 x 0.700 x 0.07
V2	591.43	7,215.59	2,640.51	3,622.33	2.00 x 0.077	1	C10 = 1.125 x 0.700 x 0.07

STRESS ANALYSIS - PAGE 3



NEW MILLENNIUM
BUILDING SYSTEMS

<i>Job Number:</i> 8010-0704	<i>Job Name:</i> 10-123 BARRHAVEN FIRE STATION - SHOPORDERS	<i>Date Run:</i> 11/19/2010 4:08:45 PM
<i>Location:</i> OTTAWA, ON	<i>Joist Description:</i> Short Span Crimp 23K704/321	<i>Mark:</i> J26

TCX Design

TCX Left		TCX Right	
TCX Length	0-2	TCX Length	0-1 1/2
TCX Type	R	TCX Type	R
TCX Depth	4	TCX Depth	4
BPL Length	0-6	BPL Length	0-5 1/2
Clear Bearing	0-6 3/8	Clear Bearing	0-5 7/8
BPL Material: 69L = 2 x 3 x .250		BPL Material: 69L = 2 x 3 x .250	

Total Load	704.00	Total Load	704.00
Reqd TL Def L/80	0.03	Reqd TL Def L/80	0.02
Live Load	481.50	Live Load	481.50
Reqd LL Def L/120	0.02	Reqd LL Def L/120	0.01
Section Modulus	0.2421	Section Modulus	0.2421
Reqd SM	0.0028	Reqd SM	0.0016
Mom of Inertia	0.3040	Mom of Inertia	0.3040
Reqd MI	0.0001	Reqd MI	0.0000

Seat Type: Lapped

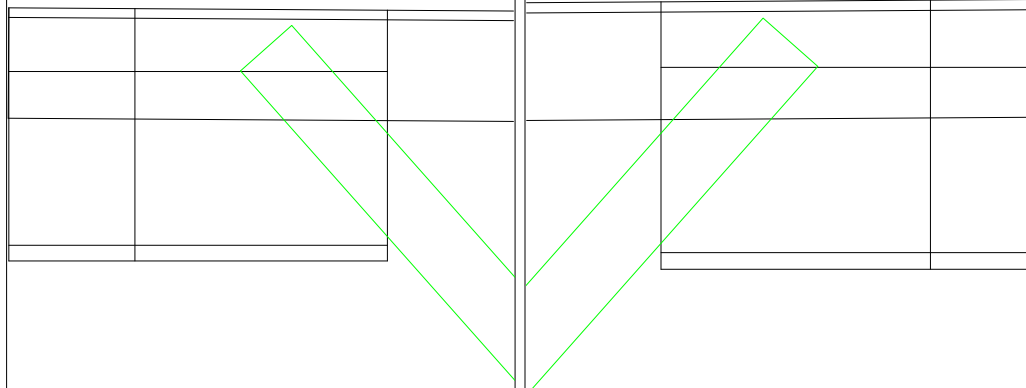

LSD Design

- | | |
|--|--|
| Case 1a: DL | Case 6a: 1.25(DL)+0.5(CL+SL)+1.4(WL+AX)+0.8(TL) |
| Case 1b: 1.4(DL) | Case 6b: 1.25(DL)+0.5(CL+SL)+1.4(WL-AX)+0.8(TL) |
| Case 2a: LL | Case 6c: 1.25(DL)+0.5(CL+SL)+1.4(WL+AX+IP)+0.8(TL) |
| Case 2b: SL | Case 6d: 1.25(DL)+0.5(CL+SL)+1.4(WL-AX+IP)+0.8(TL) |
| Case 3a: 1.25(DL+CL)+1.5(TL+LL) | Case 7a: 1.25(DL+CL)+0.4(WL+AX)+1.5(TL+LL) |
| Case 3b: 1.25(DL+CL)+1.5(TL+SL) | Case 7b: 1.25(DL+CL)+0.4(WL-AX)+1.5(TL+LL) |
| Case 3c: 1.25(DL+CL)+1.5(TL+LL+FEM) | Case 7c: 1.25(DL+CL)+0.4(WL+AX+IP)+1.5(TL+LL) |
| Case 3d: 1.25(DL+CL)+1.5(TL+SL+FEM) | Case 7d: 1.25(DL+CL)+0.4(WL-AX+IP)+1.5(TL+LL) |
| Case 3e: DL+CL+TL+LL | Case 8a: 1.25(DL+CL)+0.4(WL+AX)+1.5(TL+SL) |
| Case 3f: DL+CL+TL+SL | Case 8b: 1.25(DL+CL)+0.4(WL-AX)+1.5(TL+SL) |
| Case 4a: 1.25(DL)+0.5(CL+LL)+1.4(WL+AX)+0.8(TL) | Case 8c: 1.25(DL+CL)+0.4(WL+AX+IP)+1.5(TL+SL) |
| Case 4b: 1.25(DL)+0.5(CL+LL)+1.4(WL-AX)+0.8(TL) | Case 8d: 1.25(DL+CL)+0.4(WL-AX+IP)+1.5(TL+SL) |
| Case 4c: 1.25(DL)+0.5(CL+LL)+1.4(WL+AX+IP)+0.8(TL) | Case 9a: DL+CL+0.5(LL)+0.7(TL)+SM+AX+FEM |
| Case 4d: 1.25(DL)+0.5(CL+LL)+1.4(WL-AX+IP)+0.8(TL) | Case 9b: DL+CL+0.5(LL)+0.7(TL)+SM-AX+FEM |
| Case 4e: 1.25(DL+CL)+1.4(WL+AX)+1.1(TL)+LL | Case 9c: DL+CL+0.25(SL)+0.7(TL)+SM+AX+FEM |
| Case 4f: 1.25(DL+CL)+1.4(WL-AX)+1.1(TL)+LL | Case 9d: DL+CL+0.25(SL)+0.7(TL)+SM-AX+FEM |
| Case 5a: 0.9(DL)+1.4(WL+AX) | Case 9e: DL+CL+LL+1.1(TL)+SM+AX+FEM |
| Case 5b: 0.9(DL)+1.4(WL-AX) | Case 9f: DL+CL+LL+1.1(TL)+SM-AX+FEM |
| Case 5c: 0.9(DL)+1.4(WL+AX+IP) | Case 10a: DL+SM+AX |
| Case 5d: 0.9(DL)+1.4(WL-AX+IP) | Case 10b: DL+SM-AX |
| Case 5e: DL+SM+AX | Case 10c: DL+CL+SM+AX |
| Case 5f: DL+SM-AX | Case 10d: DL+CL+SM-AX |

STRESS ANALYSIS - PAGE 1



NEW MILLENNIUM
BUILDING SYSTEMS

Job Number: 8010-0704	Job Name: 10-123 BARRHAVEN FIRE STATION - SHOPORDERS	Date Run: 11/19/2010 4:09:20 PM
Location: OTTAWA, ON	Joist Description: Short Span Crimp 22K573/261	Mark: J28

Geometry

Base Length: 27-0	Working Length: 26-8	Joist Depth: 22.00	Effective Depth: 21.08	BC Panel Length: 6 @ 4-0	Shape: Double Pitch with Ridge @ 13-6
-----------------------------	--------------------------------	------------------------------	----------------------------------	------------------------------------	---

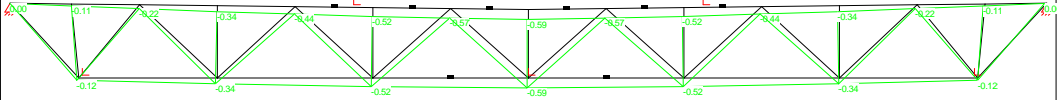
Variable	Left End	Right End	Deflection Case 2a: LL (Max Deflection: -0.59 in-Y, -0.12 in-X) 
BC Panel	1-11 1/4	1-11 1/4	
TC Panel	1-9	1-9	
First Half	1-6 3/4	1-6 3/4	
First Diag.	3-6	3-6	
Depth	24.00	24.00	

Loads, *** All loads are factored ***

Load Type	Category	Load1	Load2	Position	Direction	Loc/Begin	Sp/End
Uniform (plf)	DL	181.50	181.50	TC	+	0-0	27-0
Uniform (plf)	LL	391.50	391.50	TC	+	0-0	27-0
Net Uplift (plf)	WL	221.00	221.00	TC	-	0-0	27-0
Conc anywhere (lbs)	TL	315.00	0.00	BC	+	13-6	0-0
Conc anywhere (lbs)	TL	315.00	0.00	TC	+	13-6	0-0

Stress Analysis Summary

Int. Panel TC: 24.00	Max Panel BC: 48.00	Reaction LE: 8,258.22	Reaction RE: 8,264.11	Minimum Shear: 2,066.03	Max TC Comp.: 31,391.21	Max BC Tension: 29,956.58
--------------------------------	-------------------------------	---------------------------------	---------------------------------	-----------------------------------	-----------------------------------	-------------------------------------

Member	TC Tension	TC Compression	BC Tension	BC Compression	Web Tension	Web Comp.	Web Length	PP Dist.
W2	2,648.23	6,994.85	0.00	0.00	10,731.89	3,906.97	31.35	0-2
V1S	2,610.97	6,900.56	0.00	0.00	379.70	1,703.85	22.93	1-9
W3	2,610.97	6,900.56	12,411.87	4,684.34	3,244.05	8,909.56	29.33	1-11 1/4
W4	6,944.25	18,477.47	12,411.87	4,684.34	8,642.49	3,100.81	32.94	3-6
W5	6,944.25	18,477.47	23,451.75	8,769.24	2,474.72	6,920.40	32.53	5-6
W6	10,143.87	27,296.38	23,451.75	8,769.24	5,380.01	1,862.43	32.53	7-6
V3	10,143.87	27,296.38	23,451.75	8,769.24	452.89	1,703.34	21.67	9-6
W7	10,143.87	27,296.38	29,956.58	11,046.51	1,209.74	3,588.67	32.14	9-6
W8	11,460.51	31,391.21	29,956.58	11,046.51	3,128.23	1,142.89	32.14	11-6
V4	11,460.51	31,391.21	29,956.58	11,046.51	735.84	2,648.95	21.08	13-6
W8	11,460.51	31,391.21	29,956.58	11,046.51	3,128.23	1,142.89	32.14	13-6
W7	10,143.87	27,296.38	29,956.58	11,046.51	1,209.74	3,597.47	32.14	15-6
V5	10,143.87	27,296.38	29,956.58	11,046.51	452.89	1,520.81	21.67	17-6
W6	10,143.87	27,296.38	23,451.75	8,769.24	5,388.79	1,862.43	32.53	17-6
W5	6,944.25	18,477.46	23,451.75	8,769.24	2,474.72	6,929.06	32.53	19-6
V6	6,944.25	18,477.46	23,451.75	8,769.24	452.89	1,426.60	22.26	21-6
W4	6,944.25	18,477.46	12,411.87	4,684.34	8,651.14	3,100.81	32.94	21-6
W3	2,610.97	6,900.56	12,411.87	4,684.34	3,244.05	8,917.18	29.33	23-6
V1S	2,610.97	6,900.56	0.00	0.00	379.70	1,709.77	22.93	25-3
W2	2,648.23	6,994.85	0.00	0.00	10,739.94	3,906.97	31.35	25-0 3/4

Standard Verticals

Member	Position	Max Tension	Max Comp.	Length
V2	Interior	735.84	2,648.95	22.26

STRESS ANALYSIS - PAGE 2



NEW MILLENNIUM
BUILDING SYSTEMS

Job Number: 8010-0704	Job Name: 10-123 BARRHAVEN FIRE STATION - SHOPORDERS	Date Run: 11/19/2010 4:09:20 PM
Location: OTTAWA, ON	Joist Description: Short Span Crimp 22K573/261	Mark: J28

Chord Properties

Chord	Area	Rx	Rz	Ryy	Y	Ix	Q	Material
TC	0.4410	0.4610	0.2946	1.0962	0.4321	0.0937	1.0000	12 = 1 1/2 x 1 1/2 x .155
BC	0.4801	0.5431	0.3457	1.1847	0.4904	0.1416	0.9538	14 = 1 3/4 x 1 3/4 x .143

Axial and Bending Analysis

K: 1.00	Fy: 50,000.00	Fb: 45,000.00	Mom of Inertia: 204.46	LL 360: 402.80	LL 240: 604.21	Max Bridg TC: 13-3	Max Bridg BC: 12-9 3/8
-------------------	-------------------------	-------------------------	----------------------------------	--------------------------	--------------------------	------------------------------	----------------------------------

Top Chord Check	End Panel LE	First Panel LE	Interior Panel	First Panel RE	End Panel RE	
Length	19.00	21.00	24.00	21.00	19.00	Gap Between Chords: 1.1250
Bending Load	556.05	0.00	0.00	0.00	556.05	Min Weld Len 2X: 0.5000
Axial Load	6,994.85	6,900.56	31,391.21	6,900.56	6,994.85	Max Load Fillers TC: 31,905.58
fa	7,931.12	7,824.21	35,592.96	7,824.21	7,931.12	Max Load no Fillers TC: 24,021.53
Maximum K L/r	64.49	71.28	52.06	71.28	64.49	TC OAL/Ryy: 291.9119
Fcr	36,889.57	34,485.52	41,010.68	34,485.52	36,889.57	BC Stress: 37,428.54
Fa	33,200.61	31,036.97	36,909.61	31,036.97	33,200.61	BC L/Rz: 138.8426
F'e	168,480.59	137,917.22	105,592.87	137,917.22	168,480.59	TC Shear Stress: 17,300.79
Cm	0.9843	0.9811	0.8502	0.9811	0.9843	BC Shear Stress: 16,226.82
Panel Point Moment	2548.01	700.05	700.05	700.05	2548.01	
Mid Panel Moment	1927.87	590.67	590.67	590.67	1927.87	
Panel Point fb	14516.92	3988.45	3988.45	3988.45	14516.92	
Mid Panel fb	4443.87	1361.54	1361.54	1361.54	4443.87	
Fillers	0	0	6	0	0	
Panel Point Stress	22,448.04	11,812.66	39,581.41	11,812.66	22,448.04	
Mid Panel Stress	0.3301	0.2803	1.0009	0.2803	0.3301	

Web Design

Member	Web Tension	Allow Tension	Web Comp	Allow Comp	Weld	Qty	Material
W2	10,731.89	12,234.36	3,906.97	7,393.39	4.19 x 0.115	1	C18 = 1.125 x 1.012 x .115
W3	3,244.05	21,718.85	8,909.56	11,619.92	2.67 x 0.150	1	C28 = 1.125 x 1.347 x .150
W4	8,642.49	11,869.06	3,100.81	5,297.44	3.70 x 0.105	1	C16 = 1.125 x 0.943 x .105
W5	2,474.72	16,459.83	6,920.40	8,858.53	2.32 x 0.134	1	C22 = 1.125 x 1.086 x .134
W6	5,380.01	7,215.59	1,862.43	1,888.76	3.15 x 0.077	1	C10 = 1.125 x 0.700 x 0.07
W7	1,209.74	11,869.06	3,588.67	5,541.54	2.00 x 0.105	1	C16 = 1.125 x 0.943 x .105
W8	3,128.23	7,215.59	1,142.89	1,948.51	2.00 x 0.077	1	C10 = 1.125 x 0.700 x 0.07
W8	3,128.23	7,215.59	1,142.89	1,948.51	2.00 x 0.077	1	C10 = 1.125 x 0.700 x 0.07
W7	1,209.74	11,869.06	3,597.47	5,541.54	2.00 x 0.105	1	C16 = 1.125 x 0.943 x .105
W6	5,388.79	7,215.59	1,862.43	1,888.76	3.15 x 0.077	1	C10 = 1.125 x 0.700 x 0.07
W5	2,474.72	16,459.83	6,929.06	8,858.53	2.32 x 0.134	1	C22 = 1.125 x 1.086 x .134
W4	8,651.14	11,869.06	3,100.81	5,297.44	3.70 x 0.105	1	C16 = 1.125 x 0.943 x .105
W3	3,244.05	21,718.85	8,917.18	11,619.92	2.67 x 0.150	1	C28 = 1.125 x 1.347 x .150
W2	10,739.94	12,234.36	3,906.97	7,393.39	4.19 x 0.115	1	C18 = 1.125 x 1.012 x .115
V1	379.70	7,215.59	1,709.77	3,509.46	2.00 x 0.077	1	C10 = 1.125 x 0.700 x 0.07
V2	735.84	7,215.59	2,648.95	3,658.33	2.00 x 0.077	1	C10 = 1.125 x 0.700 x 0.07

STRESS ANALYSIS - PAGE 3



NEW MILLENNIUM
BUILDING SYSTEMS

<i>Job Number:</i> 8010-0704	<i>Job Name:</i> 10-123 BARRHAVEN FIRE STATION - SHOPORDERS	<i>Date Run:</i> 11/19/2010 4:09:20 PM
<i>Location:</i> OTTAWA, ON	<i>Joist Description:</i> Short Span Crimp 22K573/261	<i>Mark:</i> J28

TCX Design

TCX Left		TCX Right	
TCX Length	0-1 3/4	TCX Length	0-1 1/2
TCX Type	R	TCX Type	R
TCX Depth	4	TCX Depth	4
BPL Length	0-5 3/4	BPL Length	0-5 1/2
Clear Bearing	0-6 1/8	Clear Bearing	0-5 7/8
BPL Material: 69L = 2 x 3 x .250		BPL Material: 69L = 2 x 3 x .250	
Total Load	573.00	Total Load	573.00
Reqd TL Def L/80	0.02	Reqd TL Def L/80	0.02
Live Load	391.50	Live Load	391.50
Reqd LL Def L/120	0.01	Reqd LL Def L/120	0.01
Section Modulus	0.1755	Section Modulus	0.1755
Reqd SM	0.0017	Reqd SM	0.0013
Mom of Inertia	0.1874	Mom of Inertia	0.1874
Reqd MI	0.0001	Reqd MI	0.0000
Seat Type: Lapped		Seat Type: Lapped	

LSD Design

- | | |
|--|--|
| Case 1a: DL | Case 6a: 1.25(DL)+0.5(CL+SL)+1.4(WL+AX)+0.8(TL) |
| Case 1b: 1.4(DL) | Case 6b: 1.25(DL)+0.5(CL+SL)+1.4(WL-AX)+0.8(TL) |
| Case 2a: LL | Case 6c: 1.25(DL)+0.5(CL+SL)+1.4(WL+AX+IP)+0.8(TL) |
| Case 2b: SL | Case 6d: 1.25(DL)+0.5(CL+SL)+1.4(WL-AX+IP)+0.8(TL) |
| Case 3a: 1.25(DL+CL)+1.5(TL+LL) | Case 7a: 1.25(DL+CL)+0.4(WL+AX)+1.5(TL+LL) |
| Case 3b: 1.25(DL+CL)+1.5(TL+SL) | Case 7b: 1.25(DL+CL)+0.4(WL-AX)+1.5(TL+LL) |
| Case 3c: 1.25(DL+CL)+1.5(TL+LL+FEM) | Case 7c: 1.25(DL+CL)+0.4(WL+AX+IP)+1.5(TL+LL) |
| Case 3d: 1.25(DL+CL)+1.5(TL+SL+FEM) | Case 7d: 1.25(DL+CL)+0.4(WL-AX+IP)+1.5(TL+LL) |
| Case 3e: DL+CL+TL+LL | Case 8a: 1.25(DL+CL)+0.4(WL+AX)+1.5(TL+SL) |
| Case 3f: DL+CL+TL+SL | Case 8b: 1.25(DL+CL)+0.4(WL-AX)+1.5(TL+SL) |
| Case 4a: 1.25(DL)+0.5(CL+LL)+1.4(WL+AX)+0.8(TL) | Case 8c: 1.25(DL+CL)+0.4(WL+AX+IP)+1.5(TL+SL) |
| Case 4b: 1.25(DL)+0.5(CL+LL)+1.4(WL-AX)+0.8(TL) | Case 8d: 1.25(DL+CL)+0.4(WL-AX+IP)+1.5(TL+SL) |
| Case 4c: 1.25(DL)+0.5(CL+LL)+1.4(WL+AX+IP)+0.8(TL) | Case 9a: DL+CL+0.5(LL)+0.7(TL)+SM+AX+FEM |
| Case 4d: 1.25(DL)+0.5(CL+LL)+1.4(WL-AX+IP)+0.8(TL) | Case 9b: DL+CL+0.5(LL)+0.7(TL)+SM-AX+FEM |
| Case 4e: 1.25(DL+CL)+1.4(WL+AX)+1.1(TL)+LL | Case 9c: DL+CL+0.25(SL)+0.7(TL)+SM+AX+FEM |
| Case 4f: 1.25(DL+CL)+1.4(WL-AX)+1.1(TL)+LL | Case 9d: DL+CL+0.25(SL)+0.7(TL)+SM-AX+FEM |
| Case 5a: 0.9(DL)+1.4(WL+AX) | Case 9e: DL+CL+LL+1.1(TL)+SM+AX+FEM |
| Case 5b: 0.9(DL)+1.4(WL-AX) | Case 9f: DL+CL+LL+1.1(TL)+SM-AX+FEM |
| Case 5c: 0.9(DL)+1.4(WL+AX+IP) | Case 10a: DL+SM+AX |
| Case 5d: 0.9(DL)+1.4(WL-AX+IP) | Case 10b: DL+SM-AX |
| Case 5e: DL+SM+AX | Case 10c: DL+CL+SM+AX |
| Case 5f: DL+SM-AX | Case 10d: DL+CL+SM-AX |

STRESS ANALYSIS - PAGE 1



NEW MILLENNIUM
BUILDING SYSTEMS

Job Number: 8010-0704	Job Name: 10-123 BARRHAVEN FIRE STATION - SHOPORDERS	Date Run: 11/19/2010 4:09:56 PM
Location: OTTAWA, ON	Joist Description: Short Span Crimp 23K573/261	Mark: J29

Geometry

Base Length: 27-0 3/8	Working Length: 26-8 3/8	Joist Depth: 23.00	Effective Depth: 22.08	BC Panel Length: 6 @ 4-0	Shape: Double Pitch with Ridge @ 13-6 1/4
---------------------------------	------------------------------------	------------------------------	----------------------------------	------------------------------------	---

Variable	Left End	Right End
BC Panel	1-11 1/2	1-11 1/2
TC Panel	1-9 1/8	1-9 1/8
First Half	1-6 3/4	1-6 5/8
First Diag.	3-6 1/4	3-6 1/8
Depth	24.00	24.00

Deflection Case 2a: LL (Max Deflection: -0.56 in-Y, -0.11 in-X)

Loads, *** All loads are factored ***

Load Type	Category	Load1	Load2	Position	Direction	Loc/Begin	Sp/End
Uniform (plf)	DL	181.50	181.50	TC	+	0-0	27-0 3/8
Uniform (plf)	LL	391.50	391.50	TC	+	0-0	27-0 3/8
Net Uplift (plf)	WL	221.00	221.00	TC	-	0-0	27-0 3/8
Conc anywhere (lbs)	TL	315.00	0.00	BC	+	13-6 1/4	0-0
Conc anywhere (lbs)	TL	315.00	0.00	TC	+	13-6 1/4	0-0

Stress Analysis Summary

Int. Panel TC: 24.00	Max Panel BC: 48.00	Reaction LE: 8,267.18	Reaction RE: 8,273.07	Minimum Shear: 2,068.27	Max TC Comp.: 30,034.35	Max BC Tension: 28,879.54
--------------------------------	-------------------------------	---------------------------------	---------------------------------	-----------------------------------	-----------------------------------	-------------------------------------

Member	TC Tension	TC Compression	BC Tension	BC Compression	Web Tension	Web Comp.	Web Length	PP Dist.
W2	2,664.83	7,038.45	0.00	0.00	10,736.85	3,908.15	31.53	0-2
V1S	2,625.50	6,938.93	0.00	0.00	382.04	1,703.09	23.07	1-9 1/8
W3	2,625.50	6,938.93	12,353.42	4,662.38	3,208.33	8,817.76	29.53	1-11 1/2
W4	6,849.33	18,224.44	12,353.42	4,662.38	8,423.94	3,017.38	33.12	3-6 1/4
W5	6,849.33	18,224.44	22,950.64	8,582.11	2,376.42	6,665.12	32.91	5-6 1/4
W6	9,852.31	26,510.87	22,950.64	8,582.11	5,063.12	1,741.62	32.91	7-6 1/4
V3	9,852.31	26,510.87	22,950.64	8,582.11	452.89	1,696.55	22.37	9-6 1/4
W7	9,852.31	26,510.87	28,879.54	10,650.00	1,108.52	3,269.89	32.71	9-6 1/4
W8	10,966.44	30,034.35	28,879.54	10,650.00	3,054.16	1,115.92	32.71	11-6 1/4
V4	10,966.44	30,034.35	28,879.54	10,650.00	588.12	2,268.36	22.08	13-6 1/4
W8	10,966.44	30,034.35	28,871.62	10,647.40	3,054.15	1,115.92	32.71	13-6 1/4
W7	9,847.15	26,496.04	28,871.62	10,647.40	1,108.52	3,287.36	32.71	15-6 1/4
V5	9,847.15	26,496.04	28,871.62	10,647.40	452.89	1,514.02	22.37	17-6 1/4
W6	9,847.15	26,496.04	22,929.46	8,574.44	5,080.49	1,745.08	32.91	17-6 1/4
W5	6,839.20	18,197.06	22,929.46	8,574.44	2,379.80	6,682.25	32.91	19-6 1/4
V6	6,839.20	18,197.06	22,929.46	8,574.44	452.89	1,419.82	22.67	21-6 1/4
W4	6,839.20	18,197.06	12,320.00	4,649.86	8,440.96	3,020.72	33.12	21-6 1/4
W3	2,625.63	6,939.27	12,320.00	4,649.86	3,201.23	8,805.51	29.45	23-6 1/4
V1S	2,625.63	6,939.27	0.00	0.00	380.85	1,706.01	23.07	25-3 1/4
W2	2,664.84	7,038.49	0.00	0.00	10,744.97	3,908.17	31.53	25-0 7/8

Standard Verticals

Member	Position	Max Tension	Max Comp.	Length
V2	Interior	588.12	2,268.36	22.67

STRESS ANALYSIS - PAGE 2



NEW MILLENNIUM
BUILDING SYSTEMS

Job Number: 8010-0704	Job Name: 10-123 BARRHAVEN FIRE STATION - SHOPORDERS	Date Run: 11/19/2010 4:09:56 PM
Location: OTTAWA, ON	Joist Description: Short Span Crimp 23K573/261	Mark: J29

Chord Properties

Chord	Area	Rx	Rz	Ryy	Y	Ix	Q	Material
TC	0.4410	0.4610	0.2946	1.0962	0.4321	0.0937	1.0000	12 = 1 1/2 x 1 1/2 x .155
BC	0.4801	0.5431	0.3457	1.1847	0.4904	0.1416	0.9538	14 = 1 3/4 x 1 3/4 x .143

Axial and Bending Analysis

K: 1.00	Fy: 50,000.00	Fb: 45,000.00	Mom of Inertia: 224.29	LL 360: 440.34	LL 240: 660.51	Max Bridg TC: 13-3	Max Bridg BC: 13-0 3/8
-------------------	-------------------------	-------------------------	----------------------------------	--------------------------	--------------------------	------------------------------	----------------------------------

Top Chord Check	End Panel LE	First Panel LE	Interior Panel	First Panel RE	End Panel RE	
Length	19.13	21.13	24.00	21.00	19.13	Gap Between Chords: 1.1250
Bending Load	556.08	0.00	0.00	0.00	556.08	Min Weld Len 2X: 0.5000
Axial Load	7,038.45	6,938.93	30,034.35	6,939.27	7,038.49	Max Load Fillers TC: 31,906.41
fa	7,980.56	7,867.71	34,054.48	7,868.10	7,980.60	Max Load no Fillers TC: 24,022.92
Maximum K L/r	64.91	71.70	52.06	71.27	64.91	TC OAL/Ryy: 292.2540
Fcr	36,743.07	34,334.38	41,011.61	34,486.99	36,743.07	BC Stress: 36,306.73
Fa	33,068.77	30,900.94	36,910.45	31,038.29	33,068.76	BC L/Rz: 138.8426
F'e	166,304.47	136,305.50	105,604.95	137,933.00	166,304.44	TC Shear Stress: 17,317.68
Cm	0.9840	0.9808	0.8567	0.9810	0.9840	BC Shear Stress: 16,160.85
Panel Point Moment	2579.78	700.01	700.01	700.01	2567.57	
Mid Panel Moment	1947.70	590.64	590.64	590.64	1952.48	
Panel Point fb	14697.95	3988.23	3988.23	3988.23	14628.35	
Mid Panel fb	4489.59	1361.46	1361.46	1361.46	4500.60	
Fillers	0	0	6	0	0	
Panel Point Stress	22,678.50	11,855.94	38,042.71	11,856.33	22,608.95	
Mid Panel Stress	0.3335	0.2828	0.9585	0.2817	0.3337	

Web Design

Member	Web Tension	Allow Tension	Web Comp	Allow Comp	Weld	Qty	Material
W2	10,736.85	12,234.36	3,908.15	7,364.55	4.19 x 0.115	1	C18 = 1.125 x 1.012 x .115
W3	3,208.33	21,718.85	8,817.76	11,566.49	2.64 x 0.150	1	C28 = 1.125 x 1.347 x .150
W4	8,423.94	11,869.06	3,017.38	5,244.38	3.60 x 0.105	1	C16 = 1.125 x 0.943 x .105
W5	2,376.42	13,593.73	6,665.12	6,682.38	2.60 x 0.115	1	C18 = 1.125 x 1.012 x .115
W6	5,063.12	7,215.59	1,741.62	1,834.98	2.96 x 0.077	1	C10 = 1.125 x 0.700 x 0.07
W7	1,108.52	11,869.06	3,269.89	5,366.06	2.00 x 0.105	1	C16 = 1.125 x 0.943 x .105
W8	3,054.16	7,215.59	1,115.92	1,863.40	2.00 x 0.077	1	C10 = 1.125 x 0.700 x 0.07
W8	3,054.15	7,215.59	1,115.92	1,863.39	2.00 x 0.077	1	C10 = 1.125 x 0.700 x 0.07
W7	1,108.52	11,869.06	3,287.36	5,366.04	2.00 x 0.105	1	C16 = 1.125 x 0.943 x .105
W6	5,080.49	7,215.59	1,745.08	1,834.95	2.97 x 0.077	1	C10 = 1.125 x 0.700 x 0.07
W5	2,379.80	13,593.73	6,682.25	6,682.30	2.61 x 0.115	1	C18 = 1.125 x 1.012 x .115
W4	8,440.96	11,869.06	3,020.72	5,244.27	3.61 x 0.105	1	C16 = 1.125 x 0.943 x .105
W3	3,201.23	21,718.85	8,805.51	11,584.22	2.64 x 0.150	1	C28 = 1.125 x 1.347 x .150
W2	10,744.97	12,234.36	3,908.17	7,364.55	4.19 x 0.115	1	C18 = 1.125 x 1.012 x .115
V1	382.04	7,215.59	1,706.01	3,477.86	2.00 x 0.077	1	C10 = 1.125 x 0.700 x 0.07
V2	588.12	7,215.59	2,268.36	3,565.77	2.00 x 0.077	1	C10 = 1.125 x 0.700 x 0.07

STRESS ANALYSIS - PAGE 3



NEW MILLENNIUM
BUILDING SYSTEMS

<i>Job Number:</i> 8010-0704	<i>Job Name:</i> 10-123 BARRHAVEN FIRE STATION - SHOPORDERS	<i>Date Run:</i> 11/19/2010 4:09:56 PM
<i>Location:</i> OTTAWA, ON	<i>Joist Description:</i> Short Span Crimp 23K573/261	<i>Mark:</i> J29

TCX Design

TCX Left		TCX Right	
TCX Length	0-1 3/4	TCX Length	0-1 1/8
TCX Type	R	TCX Type	R
TCX Depth	4	TCX Depth	4
BPL Length	0-5 3/4	BPL Length	0-5 1/8
Clear Bearing	0-6 1/8	Clear Bearing	0-5 1/2
BPL Material: 69L = 2 x 3 x .250		BPL Material: 69L = 2 x 3 x .250	
Total Load	573.00	Total Load	573.00
Reqd TL Def L/80	0.02	Reqd TL Def L/80	0.01
Live Load	391.50	Live Load	391.50
Reqd LL Def L/120	0.01	Reqd LL Def L/120	0.01
Section Modulus	0.1755	Section Modulus	0.1755
Reqd SM	0.0017	Reqd SM	0.0007
Mom of Inertia	0.1874	Mom of Inertia	0.1874
Reqd MI	0.0001	Reqd MI	0.0000
Seat Type: Lapped		Seat Type: Lapped	

LSD Design

- | | |
|--|--|
| Case 1a: DL | Case 6a: 1.25(DL)+0.5(CL+SL)+1.4(WL+AX)+0.8(TL) |
| Case 1b: 1.4(DL) | Case 6b: 1.25(DL)+0.5(CL+SL)+1.4(WL-AX)+0.8(TL) |
| Case 2a: LL | Case 6c: 1.25(DL)+0.5(CL+SL)+1.4(WL+AX+IP)+0.8(TL) |
| Case 2b: SL | Case 6d: 1.25(DL)+0.5(CL+SL)+1.4(WL-AX+IP)+0.8(TL) |
| Case 3a: 1.25(DL+CL)+1.5(TL+LL) | Case 7a: 1.25(DL+CL)+0.4(WL+AX)+1.5(TL+LL) |
| Case 3b: 1.25(DL+CL)+1.5(TL+SL) | Case 7b: 1.25(DL+CL)+0.4(WL-AX)+1.5(TL+LL) |
| Case 3c: 1.25(DL+CL)+1.5(TL+LL+FEM) | Case 7c: 1.25(DL+CL)+0.4(WL+AX+IP)+1.5(TL+LL) |
| Case 3d: 1.25(DL+CL)+1.5(TL+SL+FEM) | Case 7d: 1.25(DL+CL)+0.4(WL-AX+IP)+1.5(TL+LL) |
| Case 3e: DL+CL+TL+LL | Case 8a: 1.25(DL+CL)+0.4(WL+AX)+1.5(TL+SL) |
| Case 3f: DL+CL+TL+SL | Case 8b: 1.25(DL+CL)+0.4(WL-AX)+1.5(TL+SL) |
| Case 4a: 1.25(DL)+0.5(CL+LL)+1.4(WL+AX)+0.8(TL) | Case 8c: 1.25(DL+CL)+0.4(WL+AX+IP)+1.5(TL+SL) |
| Case 4b: 1.25(DL)+0.5(CL+LL)+1.4(WL-AX)+0.8(TL) | Case 8d: 1.25(DL+CL)+0.4(WL-AX+IP)+1.5(TL+SL) |
| Case 4c: 1.25(DL)+0.5(CL+LL)+1.4(WL+AX+IP)+0.8(TL) | Case 9a: DL+CL+0.5(LL)+0.7(TL)+SM+AX+FEM |
| Case 4d: 1.25(DL)+0.5(CL+LL)+1.4(WL-AX+IP)+0.8(TL) | Case 9b: DL+CL+0.5(LL)+0.7(TL)+SM-AX+FEM |
| Case 4e: 1.25(DL+CL)+1.4(WL+AX)+1.1(TL)+LL | Case 9c: DL+CL+0.25(SL)+0.7(TL)+SM+AX+FEM |
| Case 4f: 1.25(DL+CL)+1.4(WL-AX)+1.1(TL)+LL | Case 9d: DL+CL+0.25(SL)+0.7(TL)+SM-AX+FEM |
| Case 5a: 0.9(DL)+1.4(WL+AX) | Case 9e: DL+CL+LL+1.1(TL)+SM+AX+FEM |
| Case 5b: 0.9(DL)+1.4(WL-AX) | Case 9f: DL+CL+LL+1.1(TL)+SM-AX+FEM |
| Case 5c: 0.9(DL)+1.4(WL+AX+IP) | Case 10a: DL+SM+AX |
| Case 5d: 0.9(DL)+1.4(WL-AX+IP) | Case 10b: DL+SM-AX |
| Case 5e: DL+SM+AX | Case 10c: DL+CL+SM+AX |
| Case 5f: DL+SM-AX | Case 10d: DL+CL+SM-AX |

STRESS ANALYSIS - PAGE 1



NEW MILLENNIUM
BUILDING SYSTEMS

Job Number: 8010-0704	Job Name: 10-123 BARRHAVEN FIRE STATION - SHOPORDERS	Date Run: 11/19/2010 3:56:57 PM
Location: OTTAWA, ON	Joist Description: Short Span Crimp 24K573/261	Mark: J30

Geometry

Base Length: 27-0 3/8	Working Length: 26-8 3/8	Joist Depth: 24.00	Effective Depth: 23.08	BC Panel Length: 6 @ 4-0	Shape: Parallel Chords
---------------------------------	------------------------------------	------------------------------	----------------------------------	------------------------------------	----------------------------------

Variable	Left End	Right End
BC Panel	2-1 1/4	2-1 1/4
TC Panel	1-9 1/8	1-9 1/8
First Half	1-5	1-4 7/8
First Diag.	3-6 1/4	3-6 1/8
Depth	24.00	24.00

Deflection Case 2a: LL (Max Deflection: -0.53 in-Y, -0.10 in-X)

Loads, *** All loads are factored ***

Load Type	Category	Load1	Load2	Position	Direction	Loc/Begin	Sp/End
Uniform (plf)	DL	181.50	181.50	TC	+	0-0	27-0 3/8
Uniform (plf)	LL	391.50	391.50	TC	+	0-0	27-0 3/8
Conc anywhere (lbs)	TL	315.00	0.00	BC	+	13-6 1/4	0-0
Conc anywhere (lbs)	TL	315.00	0.00	TC	+	13-6 1/4	0-0
Net Uplift (plf)	WL	221.00	221.00	TC	-	0-0	27-0 3/8

Stress Analysis Summary

Int. Panel TC: 24.00	Max Panel BC: 48.00	Reaction LE: 8,267.18	Reaction RE: 8,273.07	Minimum Shear: 2,068.27	Max TC Comp.: 28,732.35	Max BC Tension: 27,813.24
--------------------------------	-------------------------------	---------------------------------	---------------------------------	-----------------------------------	-----------------------------------	-------------------------------------

Member	TC Tension	TC Compression	BC Tension	BC Compression	Web Tension	Web Comp.	Web Length	PP Dist.
W2	2,863.59	7,563.44	0.00	0.00	11,095.51	4,034.75	32.76	0-2
V1S	2,795.92	7,392.20	0.00	0.00	385.79	1,714.95	23.44	1-9 1/8
W3	2,795.92	7,392.20	12,214.03	4,609.77	3,058.62	8,412.37	28.66	2-1 1/4
W4	6,728.01	17,901.65	12,214.03	4,609.77	8,234.60	2,942.04	33.30	3-6 1/4
W5	6,728.01	17,901.65	22,397.46	8,375.26	2,288.63	6,445.29	33.30	5-6 1/4
W6	9,551.51	25,701.46	22,397.46	8,375.26	4,791.89	1,635.22	33.30	7-6 1/4
W7	9,551.51	25,701.46	27,813.24	10,256.77	1,090.29	3,002.58	33.30	9-6 1/4
W8	10,491.04	28,732.35	27,813.24	10,256.77	2,984.00	1,090.29	33.30	11-6 1/4

* Symmetrical Joist

Standard Verticals

Member	Position	Max Tension	Max Comp.	Length
V2	Interior	471.07	1,919.66	23.08

STRESS ANALYSIS - PAGE 2



NEW MILLENNIUM
BUILDING SYSTEMS

Job Number: 8010-0704	Job Name: 10-123 BARRHAVEN FIRE STATION - SHOPORDERS	Date Run: 11/19/2010 3:56:57 PM
Location: OTTAWA, ON	Joist Description: Short Span Crimp 24K573/261	Mark: J30

Chord Properties

Chord	Area	Rx	Rz	Ryy	Y	Ix	Q	Material
TC	0.4410	0.4610	0.2946	1.0962	0.4321	0.0937	1.0000	12 = 1 1/2 x 1 1/2 x .155
BC	0.4801	0.5431	0.3457	1.1847	0.4904	0.1416	0.9538	14 = 1 3/4 x 1 3/4 x .143

Axial and Bending Analysis

K: 1.00	Fy: 50,000.00	Fb: 45,000.00	Mom of Inertia: 245.05	LL 360: 481.09	LL 240: 721.63	Max Bridg TC: 13-3	Max Bridg BC: 13-3 1/2
-------------------	-------------------------	-------------------------	----------------------------------	--------------------------	--------------------------	------------------------------	----------------------------------

Top Chord Check	End Panel LE	First Panel LE	Interior Panel	First Panel RE	End Panel RE	
Length	19.13	21.13	24.00	21.00	19.13	Gap Between Chords: 1.1250
Bending Load	556.09	0.00	0.00	0.00	556.09	Min Weld Len 2X: 0.5000
Axial Load	7,563.44	7,391.67	28,732.35	7,392.20	7,563.44	Max Load Fillers TC: 31,906.69
fa	8,575.81	8,381.05	32,578.21	8,381.66	8,575.81	Max Load no Fillers TC: 24,023.39
Maximum K L/r	64.91	71.70	52.06	71.27	64.91	TC OAL/Ryy: 292.2540
Fcr	36,743.50	34,334.86	41,011.91	34,487.47	36,743.50	BC Stress: 35,196.13
Fa	33,069.15	30,901.38	36,910.72	31,038.72	33,069.15	BC L/Rz: 138.8426
F'e	166,310.78	136,310.67	105,608.96	137,938.25	166,310.78	TC Shear Stress: 17,392.34
Cm	0.9828	0.9795	0.8629	0.9797	0.9828	BC Shear Stress: 16,146.78
Panel Point Moment	2579.73	700.00	700.00	700.00	2567.52	
Mid Panel Moment	1947.67	590.63	590.63	590.63	1952.44	
Panel Point fb	14697.67	3988.15	3988.15	3988.15	14628.07	
Mid Panel fb	4489.51	1361.43	1361.43	1361.43	4500.51	
Fillers	0	0	6	0	0	
Panel Point Stress	23,273.48	12,369.20	36,566.36	12,369.81	23,203.88	
Mid Panel Stress	0.3518	0.2995	0.9179	0.2983	0.3520	

Web Design

Member	Web Tension	Allow Tension	Web Comp	Allow Comp	Weld	Qty	Material
W2	11,095.51	12,234.36	4,034.75	7,168.87	4.33 x 0.115	1	C18 = 1.125 x 1.012 x .115
W3	3,058.62	21,718.85	8,412.37	11,753.98	2.52 x 0.150	1	C28 = 1.125 x 1.347 x .150
W4	8,234.60	11,869.06	2,942.04	5,190.91	3.52 x 0.105	1	C16 = 1.125 x 0.943 x .105
W5	2,288.63	13,593.73	6,445.29	6,556.56	2.52 x 0.115	1	C18 = 1.125 x 1.012 x .115
W6	4,791.89	7,215.59	1,635.22	1,783.08	2.80 x 0.077	1	C10 = 1.125 x 0.700 x 0.07
W7	1,090.29	11,869.06	3,002.58	5,190.91	2.00 x 0.105	1	C16 = 1.125 x 0.943 x .105
W8	2,984.00	7,215.59	1,090.29	1,783.08	2.00 x 0.077	1	C10 = 1.125 x 0.700 x 0.07
V1	385.79	7,215.59	1,714.95	3,399.34	2.00 x 0.077	1	C10 = 1.125 x 0.700 x 0.07
V2	471.07	7,215.59	1,919.66	3,473.34	2.00 x 0.077	1	C10 = 1.125 x 0.700 x 0.07

* Symmetrical Joist

STRESS ANALYSIS - PAGE 3



NEW MILLENNIUM
BUILDING SYSTEMS

Job Number: 8010-0704	Job Name: 10-123 BARRHAVEN FIRE STATION - SHOPORDERS	Date Run: 11/19/2010 3:56:57 PM
Location: OTTAWA, ON	Joist Description: Short Span Crimp 24K573/261	Mark: J30

TCX Design

TCX Left		TCX Right	
TCX Length	0-1 3/4	TCX Length	0-1 1/8
TCX Type	R	TCX Type	R
TCX Depth	4	TCX Depth	4
BPL Length	0-5 3/4	BPL Length	0-5 1/8
Clear Bearing	0-6 3/8	Clear Bearing	0-5 3/4
BPL Material: 69L = 2 x 3 x .250		BPL Material: 69L = 2 x 3 x .250	
Total Load	573.00	Total Load	573.00
Reqd TL Def L/80	0.02	Reqd TL Def L/80	0.01
Live Load	391.50	Live Load	391.50
Reqd LL Def L/120	0.01	Reqd LL Def L/120	0.01
Section Modulus	0.1755	Section Modulus	0.1755
Reqd SM	0.0017	Reqd SM	0.0007
Mom of Inertia	0.1874	Mom of Inertia	0.1874
Reqd MI	0.0001	Reqd MI	0.0000
Seat Type: Lapped		Seat Type: Lapped	

LSD Design

- | | |
|--|--|
| Case 1a: DL | Case 6a: 1.25(DL)+0.5(CL+SL)+1.4(WL+AX)+0.8(TL) |
| Case 1b: 1.4(DL) | Case 6b: 1.25(DL)+0.5(CL+SL)+1.4(WL-AX)+0.8(TL) |
| Case 2a: LL | Case 6c: 1.25(DL)+0.5(CL+SL)+1.4(WL+AX+IP)+0.8(TL) |
| Case 2b: SL | Case 6d: 1.25(DL)+0.5(CL+SL)+1.4(WL-AX+IP)+0.8(TL) |
| Case 3a: 1.25(DL+CL)+1.5(TL+LL) | Case 7a: 1.25(DL+CL)+0.4(WL+AX)+1.5(TL+LL) |
| Case 3b: 1.25(DL+CL)+1.5(TL+SL) | Case 7b: 1.25(DL+CL)+0.4(WL-AX)+1.5(TL+LL) |
| Case 3c: 1.25(DL+CL)+1.5(TL+LL+FEM) | Case 7c: 1.25(DL+CL)+0.4(WL+AX+IP)+1.5(TL+LL) |
| Case 3d: 1.25(DL+CL)+1.5(TL+SL+FEM) | Case 7d: 1.25(DL+CL)+0.4(WL-AX+IP)+1.5(TL+LL) |
| Case 3e: DL+CL+TL+LL | Case 8a: 1.25(DL+CL)+0.4(WL+AX)+1.5(TL+SL) |
| Case 3f: DL+CL+TL+SL | Case 8b: 1.25(DL+CL)+0.4(WL-AX)+1.5(TL+SL) |
| Case 4a: 1.25(DL)+0.5(CL+LL)+1.4(WL+AX)+0.8(TL) | Case 8c: 1.25(DL+CL)+0.4(WL+AX+IP)+1.5(TL+SL) |
| Case 4b: 1.25(DL)+0.5(CL+LL)+1.4(WL-AX)+0.8(TL) | Case 8d: 1.25(DL+CL)+0.4(WL-AX+IP)+1.5(TL+SL) |
| Case 4c: 1.25(DL)+0.5(CL+LL)+1.4(WL+AX+IP)+0.8(TL) | Case 9a: DL+CL+0.5(LL)+0.7(TL)+SM+AX+FEM |
| Case 4d: 1.25(DL)+0.5(CL+LL)+1.4(WL-AX+IP)+0.8(TL) | Case 9b: DL+CL+0.5(LL)+0.7(TL)+SM-AX+FEM |
| Case 4e: 1.25(DL+CL)+1.4(WL+AX)+1.1(TL)+LL | Case 9c: DL+CL+0.25(SL)+0.7(TL)+SM+AX+FEM |
| Case 4f: 1.25(DL+CL)+1.4(WL-AX)+1.1(TL)+LL | Case 9d: DL+CL+0.25(SL)+0.7(TL)+SM-AX+FEM |
| Case 5a: 0.9(DL)+1.4(WL+AX) | Case 9e: DL+CL+LL+1.1(TL)+SM+AX+FEM |
| Case 5b: 0.9(DL)+1.4(WL-AX) | Case 9f: DL+CL+LL+1.1(TL)+SM-AX+FEM |
| Case 5c: 0.9(DL)+1.4(WL+AX+IP) | Case 10a: DL+SM+AX |
| Case 5d: 0.9(DL)+1.4(WL-AX+IP) | Case 10b: DL+SM-AX |
| Case 5e: DL+SM+AX | Case 10c: DL+CL+SM+AX |
| Case 5f: DL+SM-AX | Case 10d: DL+CL+SM-AX |

STRESS ANALYSIS - PAGE 1



NEW MILLENNIUM
BUILDING SYSTEMS

Job Number: 8010-0704	Job Name: 10-123 BARRHAVEN FIRE STATION - SHOPORDERS	Date Run: 11/19/2010 3:56:58 PM
Location: OTTAWA, ON	Joist Description: Short Span Crimp 24K704/321	Mark: J31

Geometry

Base Length: 26-11 3/4	Working Length: 26-7 3/4	Joist Depth: 24.00	Effective Depth: 23.02	BC Panel Length: 6 @ 4-0	Shape: Parallel Chords
----------------------------------	------------------------------------	------------------------------	----------------------------------	------------------------------------	----------------------------------

Variable	Left End	Right End	Deflection Case 2a: LL (Max Deflection: -0.61 in-Y, -0.12 in-X)
BC Panel	2-0 7/8	2-0 7/8	
TC Panel	1-8 7/8	1-8 7/8	
First Half	1-5	1-5	
First Diag.	3-5 7/8	3-5 7/8	
Depth	24.00	24.00	

Loads, *** All loads are factored ***

Load Type	Category	Load1	Load2	Position	Direction	Loc/Begin	Sp/End
Uniform (plf)	DL	222.50	222.50	TC	+	0-0	26-11 3/4
Uniform (plf)	LL	481.50	481.50	TC	+	0-0	26-11 3/4
Conc anywhere (lbs)	TL	315.00	0.00	BC	+	13-5 7/8	0-0
Conc anywhere (lbs)	TL	315.00	0.00	TC	+	13-5 7/8	0-0
Net Uplift (plf)	WL	221.00	221.00	TC	-	0-0	26-11 3/4

Stress Analysis Summary

Int. Panel TC: 24.00	Max Panel BC: 48.00	Reaction LE: 9,997.45	Reaction RE: 10,003.39	Minimum Shear: 2,500.85	Max TC Comp.: 34,758.75	Max BC Tension: 33,696.34
--------------------------------	-------------------------------	---------------------------------	----------------------------------	-----------------------------------	-----------------------------------	-------------------------------------

Member	TC Tension	TC Compression	BC Tension	BC Compression	Web Tension	Web Comp.	Web Length	PP Dist.
W2	2,836.35	9,083.38	0.00	0.00	13,322.12	4,023.87	32.45	0-2
V1S	2,770.62	8,880.13	0.00	0.00	383.94	1,958.20	23.36	1-8 7/8
W3	2,770.62	8,880.13	14,766.81	4,599.15	3,077.97	10,197.23	28.62	2-0 7/8
W4	6,735.52	21,701.17	14,766.81	4,599.15	9,943.25	2,960.20	33.25	3-5 7/8
W5	6,735.52	21,701.17	27,167.55	8,397.15	2,302.38	7,780.39	33.25	5-5 7/8
W6	9,584.02	31,165.94	27,167.55	8,397.15	5,746.31	1,644.56	33.25	7-5 7/8
W7	9,584.02	31,165.94	33,696.34	10,296.15	1,095.52	3,612.86	33.25	9-5 7/8
W8	10,533.52	34,758.75	33,696.34	10,296.15	3,612.86	1,095.52	33.25	11-5 7/8

* Symmetrical Joist

Standard Verticals

Member	Position	Max Tension	Max Comp.	Length
V2	Interior	455.35	2,211.79	23.02

STRESS ANALYSIS - PAGE 2



Job Number: 8010-0704	Job Name: 10-123 BARRHAVEN FIRE STATION - SHOPORDERS	Date Run: 11/19/2010 3:56:58 PM
Location: OTTAWA, ON	Joist Description: Short Span Crimp 24K704/321	Mark: J31

Chord Properties

Chord	Area	Rx	Rz	Ryy	Y	Ix	Q	Material
TC	0.4801	0.5431	0.3457	1.1847	0.4904	0.1416	0.9538	14 = 1 3/4 x 1 3/4 x .143
BC	0.4801	0.5431	0.3457	1.1847	0.4904	0.1416	0.9538	14 = 1 3/4 x 1 3/4 x .143

Axial and Bending Analysis

K: 1.00	Fy: 50,000.00	Fb: 45,000.00	Mom of Inertia: 254.66	LL 360: 502.88	LL 240: 754.32	Max Bridg TC: 14-3 3/4	Max Bridg BC: 13-3 1/4
-------------------	-------------------------	-------------------------	----------------------------------	--------------------------	--------------------------	----------------------------------	----------------------------------

Top Chord Check	End Panel LE	First Panel LE	Interior Panel	First Panel RE	End Panel RE	
Length	18.88	21.00	24.00	21.00	18.88	Gap Between Chords: 1.1250
Bending Load	683.18	0.00	0.00	0.00	683.18	Min Weld Len 2X: 0.5000
Axial Load	9,083.38	8,880.13	34,758.75	8,880.13	9,083.38	Max Load Fillers TC: 35,645.82
fa	9,460.85	9,249.15	36,203.18	9,249.15	9,460.85	Max Load no Fillers TC: 29,219.17
Maximum K L/r	54.60	60.74	44.19	60.74	54.60	TC OAL/Ryy: 269.9021
Fcr	38,739.08	36,870.29	41,618.54	36,870.29	38,739.08	BC Stress: 41,323.70
Fa	34,865.17	33,183.26	37,456.68	33,183.26	34,865.17	BC L/Rz: 138.8426
F'e	236,971.08	191,439.11	146,570.56	191,439.11	236,971.08	TC Shear Stress: 19,503.63
Cm	0.9867	0.9839	0.8902	0.9839	0.9867	BC Shear Stress: 19,503.63
Panel Point Moment	2942.65	700.00	700.00	700.00	2942.65	
Mid Panel Moment	2190.30	590.63	590.63	590.63	2190.30	
Panel Point fb	13088.64	3113.54	3113.54	3113.54	13088.64	
Mid Panel fb	3792.56	1022.68	1022.68	1022.68	3792.56	
Fillers	0	0	6	0	0	
Panel Point Stress	22,549.49	12,362.69	39,316.72	12,362.69	22,549.49	
Mid Panel Stress	0.3525	0.3007	0.9925	0.3007	0.3525	

Web Design

Member	Web Tension	Allow Tension	Web Comp	Allow Comp	Weld	Qty	Material
W2	13,322.12	14,813.85	4,023.87	9,018.80	4.46 x 0.134	1	C22 = 1.125 x 1.086 x .134
W3	3,077.97	21,718.85	10,197.23	11,825.96	3.05 x 0.150	1	C28 = 1.125 x 1.347 x .150
W4	9,943.25	11,869.06	2,960.20	5,277.06	4.25 x 0.105	1	C16 = 1.125 x 0.943 x .105
W5	2,302.38	16,459.83	7,780.39	8,695.75	2.61 x 0.134	1	C22 = 1.125 x 1.086 x .134
W6	5,746.31	7,215.59	1,644.56	1,822.03	3.36 x 0.077	1	C10 = 1.125 x 0.700 x 0.07
W7	1,095.52	11,869.06	3,612.86	5,277.06	2.00 x 0.105	1	C16 = 1.125 x 0.943 x .105
W8	3,612.86	7,215.59	1,095.52	1,822.03	2.11 x 0.077	1	C10 = 1.125 x 0.700 x 0.07
V1	383.94	7,215.59	1,958.20	3,460.44	2.00 x 0.077	1	C10 = 1.125 x 0.700 x 0.07
V2	455.35	7,215.59	2,211.79	3,529.86	2.00 x 0.077	1	C10 = 1.125 x 0.700 x 0.07

* Symmetrical Joist

STRESS ANALYSIS - PAGE 3



NEW MILLENNIUM
BUILDING SYSTEMS

Job Number: 8010-0704	Job Name: 10-123 BARRHAVEN FIRE STATION - SHOPORDERS	Date Run: 11/19/2010 3:56:58 PM
Location: OTTAWA, ON	Joist Description: Short Span Crimp 24K704/321	Mark: J31

TCX Design

TCX Left		TCX Right	
TCX Length	0-2	TCX Length	0-1 1/2
TCX Type	R	TCX Type	R
TCX Depth	4	TCX Depth	4
BPL Length	0-6	BPL Length	0-5 1/2
Clear Bearing	0-6 1/2	Clear Bearing	0-6
BPL Material: 69L = 2 x 3 x .250		BPL Material: 69L = 2 x 3 x .250	
Total Load	704.00	Total Load	704.00
Reqd TL Def L/80	0.03	Reqd TL Def L/80	0.02
Live Load	481.50	Live Load	481.50
Reqd LL Def L/120	0.02	Reqd LL Def L/120	0.01
Section Modulus	0.2248	Section Modulus	0.2248
Reqd SM	0.0028	Reqd SM	0.0016
Mom of Inertia	0.2832	Mom of Inertia	0.2832
Reqd MI	0.0001	Reqd MI	0.0000
Seat Type: Lapped		Seat Type: Lapped	

LSD Design

- | | |
|--|--|
| Case 1a: DL | Case 6a: 1.25(DL)+0.5(CL+SL)+1.4(WL+AX)+0.8(TL) |
| Case 1b: 1.4(DL) | Case 6b: 1.25(DL)+0.5(CL+SL)+1.4(WL-AX)+0.8(TL) |
| Case 2a: LL | Case 6c: 1.25(DL)+0.5(CL+SL)+1.4(WL+AX+IP)+0.8(TL) |
| Case 2b: SL | Case 6d: 1.25(DL)+0.5(CL+SL)+1.4(WL-AX+IP)+0.8(TL) |
| Case 3a: 1.25(DL+CL)+1.5(TL+LL) | Case 7a: 1.25(DL+CL)+0.4(WL+AX)+1.5(TL+LL) |
| Case 3b: 1.25(DL+CL)+1.5(TL+SL) | Case 7b: 1.25(DL+CL)+0.4(WL-AX)+1.5(TL+LL) |
| Case 3c: 1.25(DL+CL)+1.5(TL+LL+FEM) | Case 7c: 1.25(DL+CL)+0.4(WL+AX+IP)+1.5(TL+LL) |
| Case 3d: 1.25(DL+CL)+1.5(TL+SL+FEM) | Case 7d: 1.25(DL+CL)+0.4(WL-AX+IP)+1.5(TL+LL) |
| Case 3e: DL+CL+TL+LL | Case 8a: 1.25(DL+CL)+0.4(WL+AX)+1.5(TL+SL) |
| Case 3f: DL+CL+TL+SL | Case 8b: 1.25(DL+CL)+0.4(WL-AX)+1.5(TL+SL) |
| Case 4a: 1.25(DL)+0.5(CL+LL)+1.4(WL+AX)+0.8(TL) | Case 8c: 1.25(DL+CL)+0.4(WL+AX+IP)+1.5(TL+SL) |
| Case 4b: 1.25(DL)+0.5(CL+LL)+1.4(WL-AX)+0.8(TL) | Case 8d: 1.25(DL+CL)+0.4(WL-AX+IP)+1.5(TL+SL) |
| Case 4c: 1.25(DL)+0.5(CL+LL)+1.4(WL+AX+IP)+0.8(TL) | Case 9a: DL+CL+0.5(LL)+0.7(TL)+SM+AX+FEM |
| Case 4d: 1.25(DL)+0.5(CL+LL)+1.4(WL-AX+IP)+0.8(TL) | Case 9b: DL+CL+0.5(LL)+0.7(TL)+SM-AX+FEM |
| Case 4e: 1.25(DL+CL)+1.4(WL+AX)+1.1(TL)+LL | Case 9c: DL+CL+0.25(SL)+0.7(TL)+SM+AX+FEM |
| Case 4f: 1.25(DL+CL)+1.4(WL-AX)+1.1(TL)+LL | Case 9d: DL+CL+0.25(SL)+0.7(TL)+SM-AX+FEM |
| Case 5a: 0.9(DL)+1.4(WL+AX) | Case 9e: DL+CL+LL+1.1(TL)+SM+AX+FEM |
| Case 5b: 0.9(DL)+1.4(WL-AX) | Case 9f: DL+CL+LL+1.1(TL)+SM-AX+FEM |
| Case 5c: 0.9(DL)+1.4(WL+AX+IP) | Case 10a: DL+SM+AX |
| Case 5d: 0.9(DL)+1.4(WL-AX+IP) | Case 10b: DL+SM-AX |
| Case 5e: DL+SM+AX | Case 10c: DL+CL+SM+AX |
| Case 5f: DL+SM-AX | Case 10d: DL+CL+SM-AX |

STRESS ANALYSIS - PAGE 1



NEW MILLENNIUM
BUILDING SYSTEMS

Job Number: 8010-0704	Job Name: 10-123 BARRHAVEN FIRE STATION - SHOPORDERS	Date Run: 11/19/2010 4:32:40 PM
Location: OTTAWA, ON	Joist Description: Deep Long Span 58DLH586/267	Mark: J32

Geometry

Base Length: 68-2 1/2	Working Length: 67-10 1/2	Joist Depth: 58.00	Effective Depth: 54.59	BC Panel Length: 6 @ 9-4	Shape: Parallel Chords
---------------------------------	-------------------------------------	------------------------------	----------------------------------	------------------------------------	----------------------------------

Variable	Left End	Right End
BC Panel	6-1 1/4	6-1 1/4
TC Panel	5-4 5/8	5-4 5/8
First Half	4-8	4-8
First Diag.	10-9 1/4	10-9 1/4
Depth	58.00	58.00

Deflection Case 2a: LL (Max Deflection: -0.78 in-Y, -0.10 in-X)

Loads, *** All loads are factored ***

Load Type	Category	Load1	Load2	Position	Direction	Loc/Begin	Sp/End
Uniform (plf)	DL	184.50	184.50	TC	+	0-0	68-2 1/2
Uniform (plf)	LL	400.50	400.50	TC	+	0-0	68-2 1/2
Net Uplift (plf)	WL	250.00	250.00	TC	-	0-0	68-2 1/2
Conc Load (lbs)	LL	3,375.00	0.00	TC	+	7-4	7-4
Conc Load (lbs)	LL	3,375.00	0.00	TC	+	22-10	22-10
Conc Load (lbs)	LL	3,375.00	0.00	TC	+	25-8 1/2	25-8 1/2
Conc anywhere (lbs)	TL	315.00	0.00	TC	+	34-1 1/4	0-0
Conc anywhere (lbs)	TL	315.00	0.00	BC	+	34-1 1/4	0-0
Conc Load (lbs)	LL	3,375.00	0.00	TC	+	41-2 1/4	41-2 1/4
Conc Load (lbs)	LL	3,375.00	0.00	TC	+	44-1	44-1
Conc Load (lbs)	DL	625.00	0.00	BC	+	50-11 1/2	56-11 1/2
Uniform (plf)	LL	0.00	500.00	TC	+	52-6 1/2	68-3
Conc Load (lbs)	LL	3,375.00	0.00	TC	+	59-6 7/8	59-6 7/8

Stress Analysis Summary

Int. Panel TC: 56.00	Max Panel BC: 112.00	Reaction LE: 31,436.40	Reaction RE: 35,435.92	Minimum Shear: 8,858.98	Max TC Comp.: 123,704.20	Max BC Tension: 122,834.08
--------------------------------	--------------------------------	----------------------------------	----------------------------------	-----------------------------------	------------------------------------	--------------------------------------

Member	TC Tension	TC Compression	BC Tension	BC Compression	Web Tension	Web Comp.	Web Length	PP Dist.
W2	10,449.51	42,194.12	0.00	0.00	53,753.30	13,163.56	89.76	0-2
V1S	10,235.43	41,184.19	0.00	0.00	1,371.68	8,204.19	55.26	5-4 5/8
W3	10,235.43	41,184.19	67,790.07	17,058.39	9,528.00	37,537.06	78.20	6-1 1/4
W4	22,563.73	88,059.80	67,790.07	17,058.39	29,219.57	7,687.99	78.20	10-9 1/4
W5	22,563.73	88,059.80	104,451.77	26,845.66	6,142.60	25,185.18	78.20	15-5 1/4
W6	29,904.18	117,493.75	104,451.77	26,845.66	19,266.53	4,434.15	78.20	20-1 1/4
V3	29,904.18	117,493.75	104,451.77	26,845.66	1,192.50	8,649.28	54.59	24-9 1/4
W7	29,904.18	117,493.75	122,834.08	31,739.30	3,065.52	12,691.91	78.20	24-9 1/4
W8	32,351.00	123,704.20	122,834.08	31,739.30	12,691.91	4,870.42	78.20	29-5 1/4
V4	32,351.00	123,704.20	122,834.08	31,739.30	1,192.50	3,978.52	54.59	34-1 1/4

* Symmetrical Joist

Standard Verticals

Member	Position	Max Tension	Max Comp.	Length
V2	Interior	1,642.50	8,649.28	54.59

STRESS ANALYSIS - PAGE 2



NEW MILLENNIUM
BUILDING SYSTEMS

Job Number: 8010-0704	Job Name: 10-123 BARRHAVEN FIRE STATION - SHOPORDERS	Date Run: 11/19/2010 4:32:40 PM
Location: OTTAWA, ON	Joist Description: Deep Long Span 58DLH586/267	Mark: J32

Chord Properties

Chord	Area	Rx	Rz	Ryy	Y	Ix	Q	Material
TC	6.4336	1.8520	1.1814	2.9296	1.7075	22.0655	1.0000	51 = 6 x 6 x .5625
BC	6.4336	1.8520	1.1814	2.9296	1.7075	22.0655	1.0000	51 = 6 x 6 x .5625

Axial and Bending Analysis

K: 0.75	Fy: 50,000.00	Fb: 45,000.00	Mom of Inertia: 19,213.19	LL 300: 2,754.56	TL 820: 1,007.76	Max Bridg TC: 41-6	Max Bridg BC: 58-7 1/8
-------------------	-------------------------	-------------------------	-------------------------------------	----------------------------	----------------------------	------------------------------	----------------------------------

Top Chord Check	End Panel LE	First Panel LE	Interior Panel	First Panel RE	End Panel RE	Gap Between Chords: 1.1250
Length	62.63	64.63	56.00	64.63	62.63	Min Weld Len 2X: 0.8886
Bending Load	567.66	567.66	567.66	869.25	1,002.22	Max Load Fillers TC: 563,059.31
Axial Load	38,635.41	37,804.91	123,704.20	41,184.19	42,194.12	Max Load no Fillers TC: 534,889.13
fa	3,002.63	2,938.09	9,613.93	3,200.71	3,279.20	TC OAL/Ryy: 278.0245
Maximum K L/r	53.01	54.70	35.55	54.70	53.01	BC Stress: 9,864.04
Fcr	40,713.14	40,173.90	45,586.21	40,173.90	40,713.14	BC L/Rz: 94.8062
Fa	36,641.83	36,156.51	41,027.59	36,156.51	36,641.83	TC Shear Stress: 5,118.97
F'e	250,301.23	235,048.42	556,493.19	235,048.42	250,301.23	BC Shear Stress: 5,118.97
Cm	0.9960	0.9958	0.9923	0.9955	0.9956	
Panel Point Moment	22885.74	22147.70	13995.63	33046.89	38589.20	
Mid Panel Moment	16212.69	9164.81	7559.27	13301.84	26982.25	
Panel Point fb	2226.04	2154.25	1361.32	3214.39	3753.48	
Mid Panel fb	627.29	354.60	292.48	514.66	1043.97	
Fillers	0	0	0	0	0	
Panel Point Stress	5,228.67	5,092.34	10,975.25	6,415.10	7,032.68	
Mid Panel Stress	0.0550	0.0486	0.2402	0.0558	0.0682	

Web Design

Member	Web Tension	Allow Tension	Web Comp	Allow Comp	Weld	Qty	Material
W2	53,753.30	56,851.68	13,163.56	22,052.02	14.81 x 0.163	2	17 = 2 x 2 x .163
W3	9,528.00	84,582.09	37,537.06	40,742.44	8.99 x 0.188	2	22 = 2 x 2 x .248
W4	29,219.57	37,148.29	7,687.99	8,349.35	7.00 x 0.188	1	20 = 2 x 2 x .216
W5	6,142.60	56,851.68	25,185.18	27,381.86	6.94 x 0.163	2	17 = 2 x 2 x .163
W6	19,266.53	36,889.49	4,434.15	4,534.44	4.61 x 0.188	1	C38 = 1.125 x 1.844 x .200
W7	3,065.52	43,636.64	12,691.91	17,055.89	3.98 x 0.143	2	14 = 1 3/4 x 1 3/4 x .143
W8	12,691.91	41,419.47	4,870.42	5,008.25	3.04 x 0.188	1	C40 = 1.125 x 2.006 x .209
V1	1,371.68	41,419.47	8,204.19	8,912.93	2.00 x 0.188	1	C40 = 1.125 x 2.006 x .209
V2	1,642.50	16,459.83	8,649.28	4,045.67	2.00 x 0.134	1	C22 = 1.125 x 1.086 x .134

* Symmetrical Joist

STRESS ANALYSIS - PAGE 3



NEW MILLENNIUM
BUILDING SYSTEMS

Job Number: 8010-0704	Job Name: 10-123 BARRHAVEN FIRE STATION - SHOPORDERS	Date Run: 11/19/2010 4:32:40 PM
Location: OTTAWA, ON	Joist Description: Deep Long Span 58DLH586/267	Mark: J32

TCX Design

TCX Left		TCX Right	
TCX Length	0-0 1/2	TCX Length	0-0 1/2
TCX Type	R	TCX Type	R
TCX Depth	7	TCX Depth	7
BPL Length	0-6 1/2	BPL Length	0-6 1/2
Clear Bearing	0-8 3/4	Clear Bearing	0-6 3/4
BPL Material: 50 = 6 x 6 x .500		BPL Material: 50 = 6 x 6 x .500	

Total Load	585.00	Total Load	585.00
Reqd TL Def L/80	0.01	Reqd TL Def L/80	0.01
Live Load	400.50	Live Load	400.50
Reqd LL Def L/120	0.00	Reqd LL Def L/120	0.00
Section Modulus	10.2809	Section Modulus	10.2809
Reqd SM	0.0001	Reqd SM	0.0001
Mom of Inertia	44.1311	Mom of Inertia	44.1311
Reqd MI	0.0000	Reqd MI	0.0000

Seat Type: Lapped

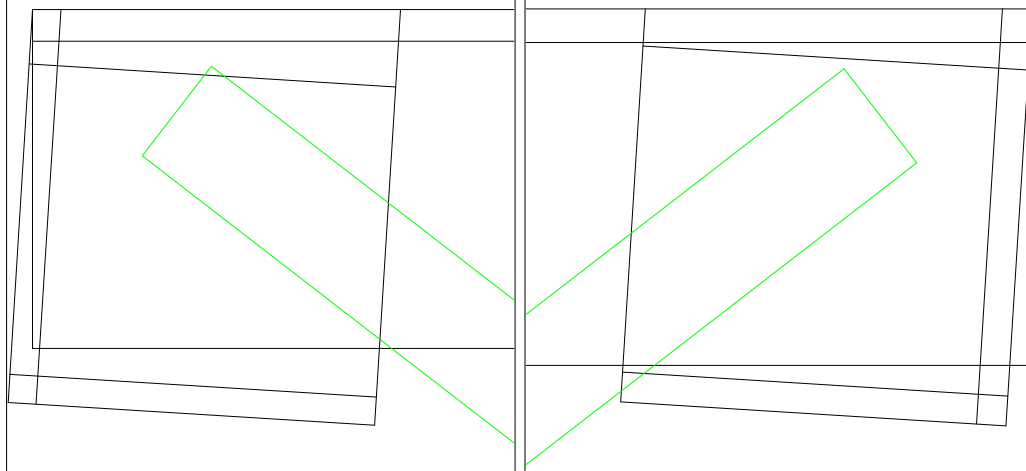

LSD Design

- | | |
|--|--|
| Case 1a: DL | Case 6a: 1.25(DL)+0.5(CL+SL)+1.4(WL+AX)+0.8(TL) |
| Case 1b: 1.4(DL) | Case 6b: 1.25(DL)+0.5(CL+SL)+1.4(WL-AX)+0.8(TL) |
| Case 2a: LL | Case 6c: 1.25(DL)+0.5(CL+SL)+1.4(WL+AX+IP)+0.8(TL) |
| Case 2b: SL | Case 6d: 1.25(DL)+0.5(CL+SL)+1.4(WL-AX+IP)+0.8(TL) |
| Case 3a: 1.25(DL+CL)+1.5(TL+LL) | Case 7a: 1.25(DL+CL)+0.4(WL+AX)+1.5(TL+LL) |
| Case 3b: 1.25(DL+CL)+1.5(TL+SL) | Case 7b: 1.25(DL+CL)+0.4(WL-AX)+1.5(TL+LL) |
| Case 3c: 1.25(DL+CL)+1.5(TL+LL+FEM) | Case 7c: 1.25(DL+CL)+0.4(WL+AX+IP)+1.5(TL+LL) |
| Case 3d: 1.25(DL+CL)+1.5(TL+SL+FEM) | Case 7d: 1.25(DL+CL)+0.4(WL-AX+IP)+1.5(TL+LL) |
| Case 3e: DL+CL+TL+LL | Case 8a: 1.25(DL+CL)+0.4(WL+AX)+1.5(TL+SL) |
| Case 3f: DL+CL+TL+SL | Case 8b: 1.25(DL+CL)+0.4(WL-AX)+1.5(TL+SL) |
| Case 4a: 1.25(DL)+0.5(CL+LL)+1.4(WL+AX)+0.8(TL) | Case 8c: 1.25(DL+CL)+0.4(WL+AX+IP)+1.5(TL+SL) |
| Case 4b: 1.25(DL)+0.5(CL+LL)+1.4(WL-AX)+0.8(TL) | Case 8d: 1.25(DL+CL)+0.4(WL-AX+IP)+1.5(TL+SL) |
| Case 4c: 1.25(DL)+0.5(CL+LL)+1.4(WL+AX+IP)+0.8(TL) | Case 9a: DL+CL+0.5(LL)+0.7(TL)+SM+AX+FEM |
| Case 4d: 1.25(DL)+0.5(CL+LL)+1.4(WL-AX+IP)+0.8(TL) | Case 9b: DL+CL+0.5(LL)+0.7(TL)+SM-AX+FEM |
| Case 4e: 1.25(DL+CL)+1.4(WL+AX)+1.1(TL)+LL | Case 9c: DL+CL+0.25(SL)+0.7(TL)+SM+AX+FEM |
| Case 4f: 1.25(DL+CL)+1.4(WL-AX)+1.1(TL)+LL | Case 9d: DL+CL+0.25(SL)+0.7(TL)+SM-AX+FEM |
| Case 5a: 0.9(DL)+1.4(WL+AX) | Case 9e: DL+CL+LL+1.1(TL)+SM+AX+FEM |
| Case 5b: 0.9(DL)+1.4(WL-AX) | Case 9f: DL+CL+LL+1.1(TL)+SM-AX+FEM |
| Case 5c: 0.9(DL)+1.4(WL+AX+IP) | Case 10a: DL+SM+AX |
| Case 5d: 0.9(DL)+1.4(WL-AX+IP) | Case 10b: DL+SM-AX |
| Case 5e: DL+SM+AX | Case 10c: DL+CL+SM+AX |
| Case 5f: DL+SM-AX | Case 10d: DL+CL+SM-AX |

STRESS ANALYSIS - PAGE 1



NEW MILLENNIUM
BUILDING SYSTEMS

Job Number: 8010-0704	Job Name: 10-123 BARRHAVEN FIRE STATION - SHOPORDERS	Date Run: 11/19/2010 4:14:03 PM
Location: OTTAWA, ON	Joist Description: Deep Long Span 58DLH515/235	Mark: J35

Geometry

Base Length: 81-4 3/4	Working Length: 81-0 3/4	Joist Depth: 58.00	Effective Depth: 55.70	BC Panel Length: 7 @ 9-4	Shape: Parallel Chords
---------------------------------	------------------------------------	------------------------------	----------------------------------	------------------------------------	----------------------------------

Variable	Left End	Right End	Deflection Case 2a: LL (Max Deflection: -2.31 in-Y, -0.32 in-X)
BC Panel	12-1	12-1	
TC Panel	7-5	7-5	
First Half	0-7 3/8	0-7 3/8	
First Diag.	12-8 3/8	12-8 3/8	
Depth	58.00	58.00	

Loads, *** All loads are factored ***

Load Type	Category	Load1	Load2	Position	Direction	Loc/Begin	Sp/End
Uniform (plf)	DL	162.50	162.50	TC	+	0-0	81-4 3/4
Uniform (plf)	LL	352.50	352.50	TC	+	0-0	81-4 3/4
Conc anywhere (lbs)	TL	315.00	0.00	BC	+	40-8 3/8	0-0
Conc anywhere (lbs)	TL	315.00	0.00	TC	+	40-8 3/8	0-0
Net Uplift (plf)	WL	250.00	250.00	TC	-	0-0	81-4 3/4
Conc Load (lbs)	LL	3,375.00	0.00	TC	+	7-4	7-4
Conc Load (lbs)	LL	3,375.00	0.00	TC	+	22-10	22-10
Conc Load (lbs)	LL	3,375.00	0.00	TC	+	25-8 1/2	25-8 1/2
Conc Load (lbs)	LL	3,375.00	0.00	TC	+	41-2 1/4	41-2 1/4
Conc Load (lbs)	LL	3,375.00	0.00	TC	+	44-1	44-1
Uniform (plf)	LL	245.00	245.00	TC	+	52-6 1/2	81-5 1/4
Conc Load (lbs)	LL	3,375.00	0.00	TC	+	59-6 7/8	59-6 7/8

Stress Analysis Summary

Int. Panel TC: 56.00	Max Panel BC: 112.00	Reaction LE: 34,905.36	Reaction RE: 35,989.49	Minimum Shear: 8,997.37	Max TC Comp.: 160,598.58	Max BC Tension: 162,635.55
--------------------------------	--------------------------------	----------------------------------	----------------------------------	-----------------------------------	------------------------------------	--------------------------------------

Member	TC Tension	TC Compression	BC Tension	BC Compression	Web Tension	Web Comp.	Web Length	PP Dist.
W2	24,149.23	84,519.11	0.00	0.00	91,566.98	25,916.55	153.47	0-2
V1S	22,543.70	79,731.64	0.00	0.00	2,264.51	10,917.34	78.98	7-5
W3	22,543.70	79,731.64	83,460.09	23,577.71	7,877.69	28,623.03	56.19	12-1
W4	30,154.67	107,970.48	83,460.09	23,577.71	34,876.45	9,276.39	78.98	12-8 3/8
W5	30,154.67	107,970.48	128,763.66	35,535.82	7,589.77	30,207.48	78.98	17-4 3/8
W6	39,721.15	142,749.45	128,763.66	35,535.82	21,821.41	5,903.16	78.98	22-0 3/8
V3	39,721.15	142,749.45	128,763.66	35,535.82	1,189.42	7,075.72	55.70	26-8 3/8
W7	39,721.15	142,749.45	153,169.53	42,710.68	4,216.54	14,798.87	78.98	26-8 3/8
W8	44,504.39	160,598.58	153,169.53	42,710.68	12,758.45	3,662.18	78.98	31-4 3/8
V4	44,504.39	160,598.58	153,169.53	42,710.68	1,189.42	3,836.33	55.70	36-0 3/8
W9	44,504.39	160,598.58	162,635.55	45,102.29	3,662.18	12,758.45	78.98	36-0 3/8

* Symmetrical Joist

Standard Verticals

Member	Position	Max Tension	Max Comp.	Length
V2	Interior	1,189.42	7,075.72	55.70

STRESS ANALYSIS - PAGE 2



NEW MILLENNIUM
BUILDING SYSTEMS

Job Number: 8010-0704	Job Name: 10-123 BARRHAVEN FIRE STATION - SHOPORDERS	Date Run: 11/19/2010 4:14:03 PM
Location: OTTAWA, ON		Joist Description: Deep Long Span 58DLH515/235
		Mark: J35

Chord Properties

Chord	Area	Rx	Rz	Ryy	Y	Ix	Q	Material
TC	3.3122	1.2260	0.7846	2.1152	1.1611	4.9786	1.0000	43 = 4 x 4 x .438
BC	2.8594	1.2346	0.7876	2.1017	1.1383	4.3586	1.0000	42 = 4 x 4 x .375

Axial and Bending Analysis

K: 0.75	Fy: 50,000.00	Fb: 45,000.00	Mom of Inertia: 9,531.57	LL 300: 802.21	TL 326: 738.23	Max Bridg TC: 29-11 5/8	Max Bridg BC: 29-5 1/4
-------------------	-------------------------	-------------------------	------------------------------------	--------------------------	--------------------------	-----------------------------------	----------------------------------

Top Chord Check	End Panel LE	First Panel LE	Interior Panel	First Panel RE	End Panel RE	
Length	87.00	63.38	56.00	63.38	87.00	Gap Between Chords: 1.1250
Bending Load	499.74	499.74	499.74	729.43	729.43	Min Weld Len 2X: 1.1536
Axial Load	83,921.28	77,323.00	160,598.58	79,731.64	84,519.11	Max Load Fillers TC: 271,620.97
fa	12,668.68	11,672.61	24,243.81	12,036.21	12,758.93	Max Load no Fillers TC: 241,843.23
Maximum K L/r	110.88	80.77	53.53	80.77	110.88	TC OAL/Ryy: 459.8962
Fcr	20,349.67	31,031.49	40,549.18	31,031.49	20,349.67	BC Stress: 29,511.38
Fa	18,314.70	27,928.34	36,494.26	27,928.34	18,314.70	BC L/Rz: 142.2093
F'e	56,840.65	107,117.80	243,892.80	107,117.80	56,840.65	TC Shear Stress: 11,464.52
Cm	0.9257	0.9637	0.9558	0.9625	0.9252	BC Shear Stress: 13,355.75
Panel Point Moment	33201.07	31535.56	12516.55	45279.06	46945.76	
Mid Panel Moment	28846.94	4711.13	6819.73	6243.02	40736.01	
Panel Point fb	9465.96	8991.11	3568.60	12909.52	13384.72	
Mid Panel fb	3363.73	549.35	795.22	727.97	4750.07	
Fillers	0	0	0	0	0	
Panel Point Stress	22,134.64	20,663.72	27,812.41	24,945.74	26,143.64	
Mid Panel Stress	0.7735	0.4298	0.6812	0.4468	0.8123	

Web Design

Member	Web Tension	Allow Tension	Web Comp	Allow Comp	Weld	Qty	Material
W2	91,566.98	119,121.80	25,916.55	35,805.63	21.93 x 0.188	2	32 = 3 x 3 x .227
W3	7,877.69	47,129.38	28,623.03	28,779.21	8.29 x 0.155	2	15 = 1 3/4 x 1 3/4 x .155
W4	34,876.45	35,653.80	9,276.39	10,023.19	11.43 x 0.137	2	10 = 1 1/2 x 1 1/2 x .137
W5	7,589.77	74,296.57	30,207.48	35,431.66	7.23 x 0.188	2	20 = 2 x 2 x .216
W6	21,821.41	28,425.84	5,903.16	6,349.06	6.01 x 0.163	1	17 = 2 x 2 x .163
W7	4,216.54	43,636.64	14,798.87	16,752.52	4.65 x 0.143	2	14 = 1 3/4 x 1 3/4 x .143
W8	12,758.45	36,889.49	3,662.18	4,455.28	3.05 x 0.188	1	C38 = 1.125 x 1.844 x .200
W9	3,662.18	43,636.64	12,758.45	16,752.52	4.01 x 0.143	2	14 = 1 3/4 x 1 3/4 x .143
V1	2,264.51	40,084.63	10,917.34	11,201.25	3.16 x 0.155	2	12 = 1 1/2 x 1 1/2 x .155
V2	1,189.42	16,459.83	7,075.72	3,908.68	2.00 x 0.134	1	C22 = 1.125 x 1.086 x .134

* Symmetrical Joist

STRESS ANALYSIS - PAGE 3



NEW MILLENNIUM
BUILDING SYSTEMS

Job Number: 8010-0704	Job Name: 10-123 BARRHAVEN FIRE STATION - SHOPORDERS	Date Run: 11/19/2010 4:14:03 PM
Location: OTTAWA, ON	Joist Description: Deep Long Span 58DLH515/235	Mark: J35

TCX Design

TCX Left		TCX Right	
TCX Length	0-0 1/2	TCX Length	0-0 1/2
TCX Type	R	TCX Type	R
TCX Depth	7	TCX Depth	7
BPL Length	0-6	BPL Length	0-6
Clear Bearing	1-0 1/8	Clear Bearing	0-8 1/8
BPL Material: 69L = 2 x 3 x .250		BPL Material: 69L = 2 x 3 x .250	

Total Load	515.00	Total Load	515.00
Reqd TL Def L/80	0.01	Reqd TL Def L/80	0.01
Live Load	352.50	Live Load	352.50
Reqd LL Def L/120	0.00	Reqd LL Def L/120	0.00
Section Modulus	3.5074	Section Modulus	3.5074
Reqd SM	0.0001	Reqd SM	0.0001
Mom of Inertia	9.9573	Mom of Inertia	9.9573
Reqd MI	0.0000	Reqd MI	0.0000

Seat Type: T-Plate

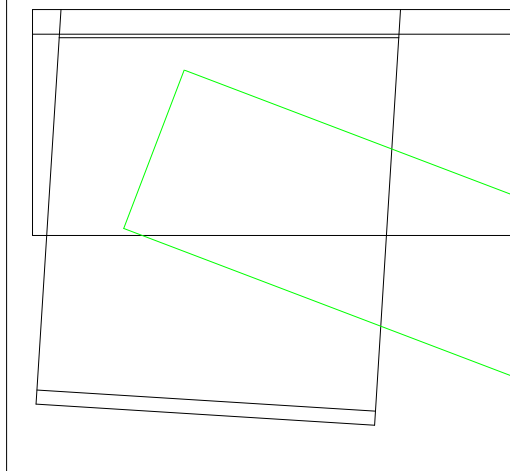

Seat Type: T-Plate

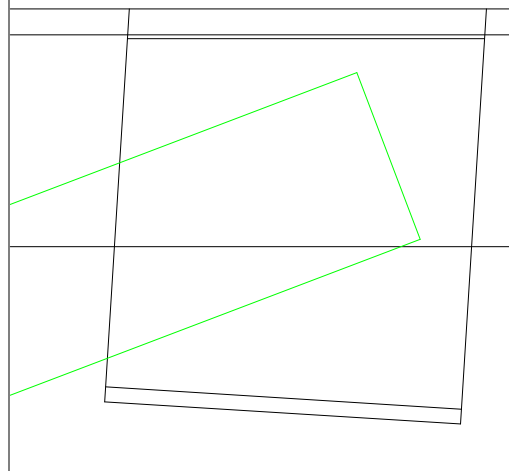

LSD Design

- | | |
|--|--|
| Case 1a: DL | Case 6a: 1.25(DL)+0.5(CL+SL)+1.4(WL+AX)+0.8(TL) |
| Case 1b: 1.4(DL) | Case 6b: 1.25(DL)+0.5(CL+SL)+1.4(WL-AX)+0.8(TL) |
| Case 2a: LL | Case 6c: 1.25(DL)+0.5(CL+SL)+1.4(WL+AX+IP)+0.8(TL) |
| Case 2b: SL | Case 6d: 1.25(DL)+0.5(CL+SL)+1.4(WL-AX+IP)+0.8(TL) |
| Case 3a: 1.25(DL+CL)+1.5(TL+LL) | Case 7a: 1.25(DL+CL)+0.4(WL+AX)+1.5(TL+LL) |
| Case 3b: 1.25(DL+CL)+1.5(TL+SL) | Case 7b: 1.25(DL+CL)+0.4(WL-AX)+1.5(TL+LL) |
| Case 3c: 1.25(DL+CL)+1.5(TL+LL+FEM) | Case 7c: 1.25(DL+CL)+0.4(WL+AX+IP)+1.5(TL+LL) |
| Case 3d: 1.25(DL+CL)+1.5(TL+SL+FEM) | Case 7d: 1.25(DL+CL)+0.4(WL-AX+IP)+1.5(TL+LL) |
| Case 3e: DL+CL+TL+LL | Case 8a: 1.25(DL+CL)+0.4(WL+AX)+1.5(TL+SL) |
| Case 3f: DL+CL+TL+SL | Case 8b: 1.25(DL+CL)+0.4(WL-AX)+1.5(TL+SL) |
| Case 4a: 1.25(DL)+0.5(CL+LL)+1.4(WL+AX)+0.8(TL) | Case 8c: 1.25(DL+CL)+0.4(WL+AX+IP)+1.5(TL+SL) |
| Case 4b: 1.25(DL)+0.5(CL+LL)+1.4(WL-AX)+0.8(TL) | Case 8d: 1.25(DL+CL)+0.4(WL-AX+IP)+1.5(TL+SL) |
| Case 4c: 1.25(DL)+0.5(CL+LL)+1.4(WL+AX+IP)+0.8(TL) | Case 9a: DL+CL+0.5(LL)+0.7(TL)+SM+AX+FEM |
| Case 4d: 1.25(DL)+0.5(CL+LL)+1.4(WL-AX+IP)+0.8(TL) | Case 9b: DL+CL+0.5(LL)+0.7(TL)+SM-AX+FEM |
| Case 4e: 1.25(DL+CL)+1.4(WL+AX)+1.1(TL)+LL | Case 9c: DL+CL+0.25(SL)+0.7(TL)+SM+AX+FEM |
| Case 4f: 1.25(DL+CL)+1.4(WL-AX)+1.1(TL)+LL | Case 9d: DL+CL+0.25(SL)+0.7(TL)+SM-AX+FEM |
| Case 5a: 0.9(DL)+1.4(WL+AX) | Case 9e: DL+CL+LL+1.1(TL)+SM+AX+FEM |
| Case 5b: 0.9(DL)+1.4(WL-AX) | Case 9f: DL+CL+LL+1.1(TL)+SM-AX+FEM |
| Case 5c: 0.9(DL)+1.4(WL+AX+IP) | Case 10a: DL+SM+AX |
| Case 5d: 0.9(DL)+1.4(WL-AX+IP) | Case 10b: DL+SM-AX |
| Case 5e: DL+SM+AX | Case 10c: DL+CL+SM+AX |
| Case 5f: DL+SM-AX | Case 10d: DL+CL+SM-AX |

STRESS ANALYSIS - PAGE 1



NEW MILLENNIUM
BUILDING SYSTEMS

Job Number: 8010-0704	Job Name: 10-123 BARRHAVEN FIRE STATION - SHOPORDERS	Date Run: 11/19/2010 3:57:00 PM
Location: OTTAWA, ON		Joist Description: Deep Long Span 58DLH515/235
		Mark: J37

Geometry

Base Length: 81-4 3/4	Working Length: 81-0 3/4	Joist Depth: 58.00	Effective Depth: 56.29	BC Panel Length: 7 @ 9-4	Shape: Parallel Chords
---------------------------------	------------------------------------	------------------------------	----------------------------------	------------------------------------	----------------------------------

Variable	Left End	Right End	Deflection Case 2a: LL (Max Deflection: -1.79 in-Y, -0.30 in-X)
BC Panel	8-0 3/8	8-0 3/8	
TC Panel	6-4 1/4	6-4 1/4	
First Half	4-8	4-8	
First Diag.	12-8 3/8	12-8 3/8	
Depth	58.00	58.00	

Loads, *** All loads are factored ***

Load Type	Category	Load1	Load2	Position	Direction	Loc/Begin	Sp/End
Uniform (plf)	DL	162.50	162.50	TC	+	0-0	81-4 3/4
Uniform (plf)	LL	352.50	352.50	TC	+	0-0	81-4 3/4
Conc anywhere (lbs)	TL	315.00	0.00	BC	+	40-8 3/8	0-0
Conc anywhere (lbs)	TL	315.00	0.00	TC	+	40-8 3/8	0-0
Net Uplift (plf)	WL	250.00	250.00	TC	-	0-0	81-4 3/4
Conc Load (lbs)	LL	1,700.00	0.00	TC	+	19-11 1/2	25-11 1/2
Conc Load (lbs)	LL	1,700.00	0.00	TC	+	26-11 1/2	32-11 1/2
Conc Load (lbs)	LL	1,700.00	0.00	TC	+	48-11 1/2	54-11 1/2
Conc Load (lbs)	LL	1,700.00	0.00	TC	+	54-11 1/2	60-11 1/2
Conc Load (lbs)	LL	1,700.00	0.00	TC	+	72-11 1/2	78-11 1/2

Stress Analysis Summary

Int. Panel TC: 56.00	Max Panel BC: 112.00	Reaction LE: 25,325.68	Reaction RE: 26,779.06	Minimum Shear: 6,694.76	Max TC Comp.: 114,280.76	Max BC Tension 115,461.19
--------------------------------	--------------------------------	----------------------------------	----------------------------------	-----------------------------------	------------------------------------	-------------------------------------

Member	TC Tension	TC Compression	BC Tension	BC Compression	Web Tension	Web Comp.	Web Length	PP Dist.
W2	15,997.01	41,112.49	0.00	0.00	49,165.00	18,626.65	109.89	0-2
V1S	15,426.09	39,550.72	0.00	0.00	1,695.94	10,142.16	59.78	6-4 1/4
W3	15,426.09	39,550.72	59,600.15	23,329.71	11,206.66	28,786.87	79.40	8-0 3/8
W4	29,837.49	76,273.75	59,600.15	23,329.71	24,787.73	9,227.47	79.40	12-8 3/8
W5	29,837.49	76,273.75	90,556.52	35,162.04	7,549.75	21,222.24	79.40	17-4 3/8
W6	39,303.35	102,354.08	90,556.52	35,162.04	17,832.24	5,872.03	79.40	22-0 3/8
V3	39,303.35	102,354.08	90,556.52	35,162.04	1,189.42	4,405.32	56.29	26-8 3/8
W7	39,303.35	102,354.08	110,164.01	42,261.43	4,194.31	12,464.20	79.40	26-8 3/8
W8	44,036.28	114,280.76	110,164.01	42,261.43	9,443.24	3,642.87	79.40	31-4 3/8
V4	44,036.28	114,280.76	110,164.01	42,261.43	1,189.42	3,604.74	56.29	36-0 3/8
W9	44,036.28	114,280.76	115,461.19	44,627.89	3,642.87	9,443.24	79.40	36-0 3/8

* Symmetrical Joist

Standard Verticals

Member	Position	Max Tension	Max Comp.	Length
V2	Interior	2,067.50	5,304.74	56.29

STRESS ANALYSIS - PAGE 2



Job Number: 8010-0704	Job Name: 10-123 BARRHAVEN FIRE STATION - SHOPORDERS	Date Run: 11/19/2010 3:57:00 PM
Location: OTTAWA, ON		Joist Description: Deep Long Span 58DLH515/235
		Mark: J37

Chord Properties

Chord	Area	Rx	Rz	Ryy	Y	Ix	Q	Material
TC	1.6070	0.9260	0.5907	1.6920	0.8536	1.3780	1.0000	34 = 3 x 3 x .281
BC	1.6070	0.9260	0.5907	1.6920	0.8536	1.3780	1.0000	34 = 3 x 3 x .281

Axial and Bending Analysis

K: 0.75	Fy: 50,000.00	Fb: 45,000.00	Mom of Inertia: 5,095.25	LL 360: 357.36	LL 240: 536.04	Max Bridg TC: 23-11 5/8	Max Bridg BC: 16-11 7/8
-------------------	-------------------------	-------------------------	------------------------------------	--------------------------	--------------------------	-----------------------------------	-----------------------------------

Top Chord Check	End Panel LE	First Panel LE	Interior Panel	First Panel RE	End Panel RE	
Length	74.25	76.13	56.00	76.13	74.25	Gap Between Chords: 1.1250
Bending Load	499.74	499.74	499.74	499.74	499.74	Min Weld Len 2X: 0.8209
Axial Load	38,841.09	37,687.49	114,280.76	39,550.72	41,112.49	Max Load Fillers TC: 118,132.91
fa	12,084.68	11,725.76	35,556.31	12,305.46	12,791.38	Max Load no Fillers TC: 96,436.74
Maximum K L/r	80.18	82.21	47.40	82.21	80.18	TC OAL/Ryy: 574.9000
Fcr	31,247.35	30,505.07	42,424.75	30,505.07	31,247.35	BC Stress: 38,467.57
Fa	28,122.62	27,454.56	38,182.27	27,454.56	28,122.62	BC L/Rz: 189.6082
F'e	44,518.25	42,352.24	139,133.72	42,352.24	44,518.25	TC Shear Stress: 16,318.58
Cm	0.9095	0.9077	0.8864	0.9031	0.9042	BC Shear Stress: 16,318.58
Panel Point Moment	28500.70	27324.90	12516.55	27324.90	28500.70	
Mid Panel Moment	19834.95	11535.63	6819.73	11535.63	19834.95	
Panel Point fb	22195.59	21279.90	9747.56	21279.90	22195.59	
Mid Panel fb	6143.57	3572.98	2112.31	3572.98	6143.57	
Fillers	1	1	8	1	1	
Panel Point Stress	34,280.26	33,005.66	45,303.87	33,585.37	34,986.96	
Mid Panel Stress	0.5878	0.5196	0.9829	0.5423	0.6160	

Web Design

Member	Web Tension	Allow Tension	Web Comp	Allow Comp	Weld	Qty	Material
W2	49,165.00	74,296.57	18,626.65	19,028.03	11.77 x 0.188	2	20 = 2 x 2 x .216
W3	11,206.66	65,039.63	28,786.87	29,498.59	6.91 x 0.187	2	A36 = 2.0938 x .187
W4	24,787.73	33,914.79	9,227.47	9,458.19	8.56 x 0.130	2	09A = 1 1/2 x 1 1/2 x .130
W5	7,549.75	56,851.68	21,222.24	26,809.57	5.85 x 0.163	2	17 = 2 x 2 x .163
W6	17,832.24	28,425.84	5,872.03	6,282.29	4.91 x 0.163	1	17 = 2 x 2 x .163
W7	4,194.31	43,636.64	12,464.20	16,591.25	3.91 x 0.143	2	14 = 1 3/4 x 1 3/4 x .143
W8	9,443.24	36,889.49	3,642.87	4,413.76	2.26 x 0.188	1	C38 = 1.125 x 1.844 x .200
W9	3,642.87	33,914.79	9,443.24	9,458.19	3.26 x 0.130	2	09A = 1 1/2 x 1 1/2 x .130
V1	1,695.94	28,425.84	10,142.16	11,044.29	2.79 x 0.163	1	17 = 2 x 2 x .163
V2	2,067.50	16,459.83	5,304.74	3,838.63	2.00 x 0.134	1	C22 = 1.125 x 1.086 x .134

* Symmetrical Joist

STRESS ANALYSIS - PAGE 3



NEW MILLENNIUM
BUILDING SYSTEMS

Job Number: 8010-0704	Job Name: 10-123 BARRHAVEN FIRE STATION - SHOPORDERS	Date Run: 11/19/2010 3:57:00 PM
Location: OTTAWA, ON	Joist Description: Deep Long Span 58DLH515/235	Mark: J37

TCX Design

TCX Left		TCX Right	
TCX Length	0-0 1/2	TCX Length	0-0 1/2
TCX Type	R	TCX Type	R
TCX Depth	7	TCX Depth	7
BPL Length	0-6	BPL Length	0-6
Clear Bearing	0-11 3/8	Clear Bearing	0-8 1/2
BPL Material: 69L = 2 x 3 x .250		BPL Material: 69L = 2 x 3 x .250	

Total Load	515.00	Total Load	515.00
Reqd TL Def L/80	0.01	Reqd TL Def L/80	0.01
Live Load	352.50	Live Load	352.50
Reqd LL Def L/120	0.00	Reqd LL Def L/120	0.00
Section Modulus	1.2841	Section Modulus	1.2841
Reqd SM	0.0001	Reqd SM	0.0001
Mom of Inertia	2.7561	Mom of Inertia	2.7561
Reqd MI	0.0000	Reqd MI	0.0000

Seat Type: T-Plate

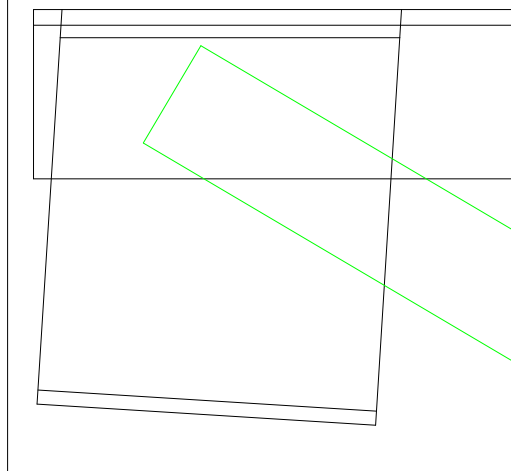

Seat Type: T-Plate

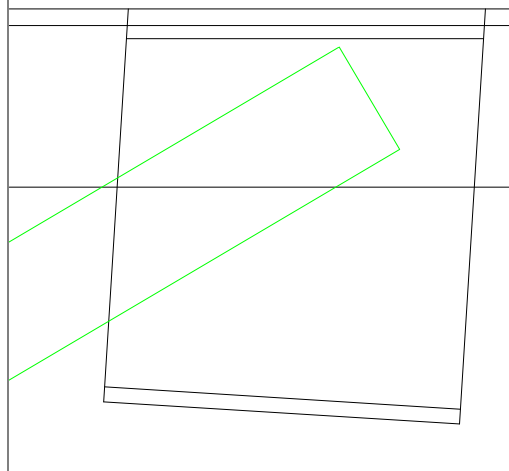

LSD Design

- | | |
|--|--|
| Case 1a: DL | Case 6a: 1.25(DL)+0.5(CL+SL)+1.4(WL+AX)+0.8(TL) |
| Case 1b: 1.4(DL) | Case 6b: 1.25(DL)+0.5(CL+SL)+1.4(WL-AX)+0.8(TL) |
| Case 2a: LL | Case 6c: 1.25(DL)+0.5(CL+SL)+1.4(WL+AX+IP)+0.8(TL) |
| Case 2b: SL | Case 6d: 1.25(DL)+0.5(CL+SL)+1.4(WL-AX+IP)+0.8(TL) |
| Case 3a: 1.25(DL+CL)+1.5(TL+LL) | Case 7a: 1.25(DL+CL)+0.4(WL+AX)+1.5(TL+LL) |
| Case 3b: 1.25(DL+CL)+1.5(TL+SL) | Case 7b: 1.25(DL+CL)+0.4(WL-AX)+1.5(TL+LL) |
| Case 3c: 1.25(DL+CL)+1.5(TL+LL+FEM) | Case 7c: 1.25(DL+CL)+0.4(WL+AX+IP)+1.5(TL+LL) |
| Case 3d: 1.25(DL+CL)+1.5(TL+SL+FEM) | Case 7d: 1.25(DL+CL)+0.4(WL-AX+IP)+1.5(TL+LL) |
| Case 3e: DL+CL+TL+LL | Case 8a: 1.25(DL+CL)+0.4(WL+AX)+1.5(TL+SL) |
| Case 3f: DL+CL+TL+SL | Case 8b: 1.25(DL+CL)+0.4(WL-AX)+1.5(TL+SL) |
| Case 4a: 1.25(DL)+0.5(CL+LL)+1.4(WL+AX)+0.8(TL) | Case 8c: 1.25(DL+CL)+0.4(WL+AX+IP)+1.5(TL+SL) |
| Case 4b: 1.25(DL)+0.5(CL+LL)+1.4(WL-AX)+0.8(TL) | Case 8d: 1.25(DL+CL)+0.4(WL-AX+IP)+1.5(TL+SL) |
| Case 4c: 1.25(DL)+0.5(CL+LL)+1.4(WL+AX+IP)+0.8(TL) | Case 9a: DL+CL+0.5(LL)+0.7(TL)+SM+AX+FEM |
| Case 4d: 1.25(DL)+0.5(CL+LL)+1.4(WL-AX+IP)+0.8(TL) | Case 9b: DL+CL+0.5(LL)+0.7(TL)+SM-AX+FEM |
| Case 4e: 1.25(DL+CL)+1.4(WL+AX)+1.1(TL)+LL | Case 9c: DL+CL+0.25(SL)+0.7(TL)+SM+AX+FEM |
| Case 4f: 1.25(DL+CL)+1.4(WL-AX)+1.1(TL)+LL | Case 9d: DL+CL+0.25(SL)+0.7(TL)+SM-AX+FEM |
| Case 5a: 0.9(DL)+1.4(WL+AX) | Case 9e: DL+CL+LL+1.1(TL)+SM+AX+FEM |
| Case 5b: 0.9(DL)+1.4(WL-AX) | Case 9f: DL+CL+LL+1.1(TL)+SM-AX+FEM |
| Case 5c: 0.9(DL)+1.4(WL+AX+IP) | Case 10a: DL+SM+AX |
| Case 5d: 0.9(DL)+1.4(WL-AX+IP) | Case 10b: DL+SM-AX |
| Case 5e: DL+SM+AX | Case 10c: DL+CL+SM+AX |
| Case 5f: DL+SM-AX | Case 10d: DL+CL+SM-AX |

STRESS ANALYSIS - PAGE 1



NEW MILLENNIUM
BUILDING SYSTEMS

Job Number: 8010-0704	Job Name: 10-123 BARRHAVEN FIRE STATION - SHOPORDERS	Date Run: 11/19/2010 3:57:01 PM
Location: OTTAWA, ON	Joist Description: Deep Long Span 58DLH515/235	Mark: J39

Geometry

Base Length: 81-4 3/4	Working Length: 81-0 3/4	Joist Depth: 58.00	Effective Depth: 56.30	BC Panel Length: 7 @ 9-4	Shape: Parallel Chords
---------------------------------	------------------------------------	------------------------------	----------------------------------	------------------------------------	----------------------------------

Variable	Left End	Right End	Deflection Case 2a: LL (Max Deflection: -1.89 in-Y, -0.33 in-X)
BC Panel	8-0 3/8	8-0 3/8	
TC Panel	6-4 1/4	6-4 1/4	
First Half	4-8	4-8	
First Diag.	12-8 3/8	12-8 3/8	
Depth	58.00	58.00	

Loads, *** All loads are factored ***

Load Type	Category	Load1	Load2	Position	Direction	Loc/Begin	Sp/End
Uniform (plf)	DL	162.50	162.50	TC	+	0-0	81-4 3/4
Uniform (plf)	LL	352.50	352.50	TC	+	0-0	81-4 3/4
Conc anywhere (lbs)	TL	315.00	0.00	BC	+	40-8 3/8	0-0
Conc anywhere (lbs)	TL	315.00	0.00	TC	+	40-8 3/8	0-0
Net Uplift (plf)	WL	250.00	250.00	TC	-	0-0	81-4 3/4

Stress Analysis Summary

Int. Panel TC: 56.00	Max Panel BC: 112.00	Reaction LE: 21,499.70	Reaction RE: 21,501.65	Minimum Shear: 5,375.41	Max TC Comp.: 91,369.64	Max BC Tension: 92,721.46
--------------------------------	--------------------------------	----------------------------------	----------------------------------	-----------------------------------	-----------------------------------	-------------------------------------

Member	TC Tension	TC Compression	BC Tension	BC Compression	Web Tension	Web Comp.	Web Length	PP Dist.
W2	15,993.82	32,845.07	0.00	0.00	38,857.26	18,623.90	109.89	0-2
V1S	15,423.01	31,691.70	0.00	0.00	1,695.90	4,500.99	59.79	6-4 1/4
W3	15,423.01	31,691.70	47,971.85	23,325.05	11,205.54	23,390.59	79.41	8-0 3/8
W4	29,831.53	61,432.13	47,971.85	23,325.05	19,391.84	9,226.55	79.41	12-8 3/8
W5	29,831.53	61,432.13	72,502.04	35,155.01	7,549.00	15,900.71	79.41	17-4 3/8
W6	39,295.50	81,181.59	72,502.04	35,155.01	12,511.04	5,871.44	79.41	22-0 3/8
W7	39,295.50	81,181.59	87,470.80	42,252.98	4,193.89	9,019.91	79.41	26-8 3/8
W8	44,027.48	91,369.64	87,470.80	42,252.98	7,581.49	3,642.50	79.41	31-4 3/8
W9	44,027.48	91,369.64	92,721.46	44,618.98	3,642.50	7,581.49	79.41	36-0 3/8

* Symmetrical Joist

Standard Verticals

Member	Position	Max Tension	Max Comp.	Length
V2	Interior	1,189.42	3,490.18	56.30

STRESS ANALYSIS - PAGE 2



NEW MILLENNIUM
BUILDING SYSTEMS

Job Number: 8010-0704	Job Name: 10-123 BARRHAVEN FIRE STATION - SHOPORDERS	Date Run: 11/19/2010 3:57:01 PM
Location: OTTAWA, ON		Joist Description: Deep Long Span 58DLH515/235
		Mark: J39

Chord Properties

Chord	Area	Rx	Rz	Ryy	Y	Ix	Q	Material
TC	1.4375	0.9304	0.5924	1.6850	0.8424	1.2442	0.9613	33 = 3 x 3 x .250
BC	1.6070	0.9260	0.5907	1.6920	0.8536	1.3780	1.0000	34 = 3 x 3 x .281

Axial and Bending Analysis

K: 0.75	Fy: 50,000.00	Fb: 45,000.00	Mom of Inertia: 4,813.46	LL 360: 337.60	LL 240: 506.39	Max Bridg TC: 23-10 1/2	Max Bridg BC: 16-11 7/8
-------------------	-------------------------	-------------------------	------------------------------------	--------------------------	--------------------------	-----------------------------------	-----------------------------------

Top Chord Check	End Panel LE	First Panel LE	Interior Panel	First Panel RE	End Panel RE	
Length	74.25	76.13	56.00	76.13	74.25	Gap Between Chords: 1.1250
Bending Load	499.74	499.74	499.74	499.74	499.74	Min Weld Len 2X: 0.6563
Axial Load	32,845.07	31,691.70	91,369.64	31,691.70	32,845.07	Max Load Fillers TC: 101,562.38
fa	11,424.37	11,023.20	31,780.74	11,023.20	11,424.37	Max Load no Fillers TC: 83,668.24
Maximum K L/r	79.81	81.82	47.27	81.82	79.81	TC OAL/Ryy: 577.2943
Fcr	30,718.75	30,023.40	41,080.29	30,023.40	30,718.75	BC Stress: 31,392.53
Fa	27,646.88	27,021.06	36,972.26	27,021.06	27,646.88	BC L/Rz: 189.6082
F'e	44,936.68	42,750.31	140,441.45	42,750.31	44,936.68	TC Shear Stress: 14,485.59
Cm	0.9153	0.9140	0.8994	0.9140	0.9153	BC Shear Stress: 12,898.78
Panel Point Moment	28500.70	27324.90	12516.55	27324.90	28500.70	
Mid Panel Moment	19834.95	11535.63	6819.73	11535.63	19834.95	
Panel Point fb	24711.22	23691.76	10852.34	23691.76	24711.22	
Mid Panel fb	6714.46	3905.00	2308.59	3905.00	6714.46	
Fillers	1	1	4	1	1	
Panel Point Stress	36,135.59	34,714.96	42,633.08	34,714.96	36,135.59	
Mid Panel Stress	0.5892	0.5107	0.9166	0.5107	0.5892	

Web Design

Member	Web Tension	Allow Tension	Web Comp	Allow Comp	Weld	Qty	Material
W2	38,857.26	74,296.57	18,623.90	19,026.03	9.30 x 0.188	2	20 = 2 x 2 x .216
W3	11,205.54	56,851.68	23,390.59	26,805.78	6.44 x 0.163	2	17 = 2 x 2 x .163
W4	19,391.84	33,914.79	9,226.55	9,456.29	6.70 x 0.130	2	09A = 1 1/2 x 1 1/2 x .130
W5	7,549.00	43,636.64	15,900.71	16,588.18	4.99 x 0.143	2	14 = 1 3/4 x 1 3/4 x .143
W6	12,511.04	28,425.84	5,871.44	6,281.03	3.45 x 0.163	1	17 = 2 x 2 x .163
W7	4,193.89	42,291.04	9,019.91	9,159.93	2.16 x 0.188	1	22 = 2 x 2 x .248
W8	7,581.49	36,889.49	3,642.50	4,412.97	2.00 x 0.188	1	C38 = 1.125 x 1.844 x .200
W9	3,642.50	37,148.29	7,581.49	8,096.99	2.00 x 0.188	1	20 = 2 x 2 x .216
V1	1,695.90	25,317.00	4,500.99	5,142.29	2.00 x 0.163	1	C32 = 1.125 x 1.479 x .163
V2	1,189.42	16,459.83	3,490.18	3,837.32	2.00 x 0.134	1	C22 = 1.125 x 1.086 x .134

* Symmetrical Joist

STRESS ANALYSIS - PAGE 3



NEW MILLENNIUM
BUILDING SYSTEMS

<i>Job Number:</i> 8010-0704	<i>Job Name:</i> 10-123 BARRHAVEN FIRE STATION - SHOPORDERS	<i>Date Run:</i> 11/19/2010 3:57:01 PM
<i>Location:</i> OTTAWA, ON	<i>Joist Description:</i> Deep Long Span 58DLH515/235	<i>Mark:</i> J39

TCX Design

TCX Left		TCX Right	
TCX Length	0-0 1/2	TCX Length	0-0 1/2
TCX Type	R	TCX Type	R
TCX Depth	7	TCX Depth	7
BPL Length	0-6	BPL Length	0-6
Clear Bearing	0-11 1/2	Clear Bearing	0-8 5/8
BPL Material: 69L = 2 x 3 x .250		BPL Material: 69L = 2 x 3 x .250	

Total Load	515.00	Total Load	515.00
Reqd TL Def L/80	0.01	Reqd TL Def L/80	0.01
Live Load	352.50	Live Load	352.50
Reqd LL Def L/120	0.00	Reqd LL Def L/120	0.00
Section Modulus	1.1534	Section Modulus	1.1534
Reqd SM	0.0001	Reqd SM	0.0001
Mom of Inertia	2.4885	Mom of Inertia	2.4885
Reqd MI	0.0000	Reqd MI	0.0000

Seat Type: T-Plate

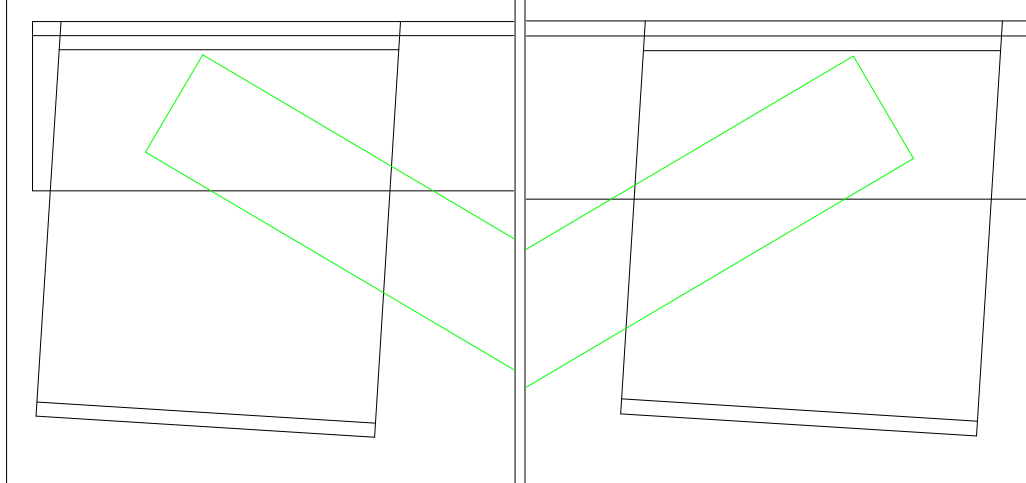

LSD Design

- | | |
|--|--|
| Case 1a: DL | Case 6a: 1.25(DL)+0.5(CL+SL)+1.4(WL+AX)+0.8(TL) |
| Case 1b: 1.4(DL) | Case 6b: 1.25(DL)+0.5(CL+SL)+1.4(WL-AX)+0.8(TL) |
| Case 2a: LL | Case 6c: 1.25(DL)+0.5(CL+SL)+1.4(WL+AX+IP)+0.8(TL) |
| Case 2b: SL | Case 6d: 1.25(DL)+0.5(CL+SL)+1.4(WL-AX+IP)+0.8(TL) |
| Case 3a: 1.25(DL+CL)+1.5(TL+LL) | Case 7a: 1.25(DL+CL)+0.4(WL+AX)+1.5(TL+LL) |
| Case 3b: 1.25(DL+CL)+1.5(TL+SL) | Case 7b: 1.25(DL+CL)+0.4(WL-AX)+1.5(TL+LL) |
| Case 3c: 1.25(DL+CL)+1.5(TL+LL+FEM) | Case 7c: 1.25(DL+CL)+0.4(WL+AX+IP)+1.5(TL+LL) |
| Case 3d: 1.25(DL+CL)+1.5(TL+SL+FEM) | Case 7d: 1.25(DL+CL)+0.4(WL-AX+IP)+1.5(TL+LL) |
| Case 3e: DL+CL+TL+LL | Case 8a: 1.25(DL+CL)+0.4(WL+AX)+1.5(TL+SL) |
| Case 3f: DL+CL+TL+SL | Case 8b: 1.25(DL+CL)+0.4(WL-AX)+1.5(TL+SL) |
| Case 4a: 1.25(DL)+0.5(CL+LL)+1.4(WL+AX)+0.8(TL) | Case 8c: 1.25(DL+CL)+0.4(WL+AX+IP)+1.5(TL+SL) |
| Case 4b: 1.25(DL)+0.5(CL+LL)+1.4(WL-AX)+0.8(TL) | Case 8d: 1.25(DL+CL)+0.4(WL-AX+IP)+1.5(TL+SL) |
| Case 4c: 1.25(DL)+0.5(CL+LL)+1.4(WL+AX+IP)+0.8(TL) | Case 9a: DL+CL+0.5(LL)+0.7(TL)+SM+AX+FEM |
| Case 4d: 1.25(DL)+0.5(CL+LL)+1.4(WL-AX+IP)+0.8(TL) | Case 9b: DL+CL+0.5(LL)+0.7(TL)+SM-AX+FEM |
| Case 4e: 1.25(DL+CL)+1.4(WL+AX)+1.1(TL)+LL | Case 9c: DL+CL+0.25(SL)+0.7(TL)+SM+AX+FEM |
| Case 4f: 1.25(DL+CL)+1.4(WL-AX)+1.1(TL)+LL | Case 9d: DL+CL+0.25(SL)+0.7(TL)+SM-AX+FEM |
| Case 5a: 0.9(DL)+1.4(WL+AX) | Case 9e: DL+CL+LL+1.1(TL)+SM+AX+FEM |
| Case 5b: 0.9(DL)+1.4(WL-AX) | Case 9f: DL+CL+LL+1.1(TL)+SM-AX+FEM |
| Case 5c: 0.9(DL)+1.4(WL+AX+IP) | Case 10a: DL+SM+AX |
| Case 5d: 0.9(DL)+1.4(WL-AX+IP) | Case 10b: DL+SM-AX |
| Case 5e: DL+SM+AX | Case 10c: DL+CL+SM+AX |
| Case 5f: DL+SM-AX | Case 10d: DL+CL+SM-AX |

STRESS ANALYSIS - PAGE 1



NEW MILLENNIUM
BUILDING SYSTEMS

Job Number: 8010-0704	Job Name: 10-123 BARRHAVEN FIRE STATION - SHOPORDERS	Date Run: 11/19/2010 3:57:02 PM
Location: OTTAWA, ON	Joist Description: Deep Long Span 58DLH515/235	Mark: J42

Geometry

Base Length: 81-4 3/4	Working Length: 81-0 3/4	Joist Depth: 58.00	Effective Depth: 56.29	BC Panel Length: 7 @ 9-4	Shape: Parallel Chords
---------------------------------	------------------------------------	------------------------------	----------------------------------	------------------------------------	----------------------------------

Variable	Left End	Right End	Deflection Case 2a: LL (Max Deflection: -1.79 in-Y, -0.30 in-X)
BC Panel	8-0 3/8	8-0 3/8	
TC Panel	6-4 1/4	6-4 1/4	
First Half	4-8	4-8	
First Diag.	12-8 3/8	12-8 3/8	
Depth	58.00	58.00	

Loads, *** All loads are factored ***

Load Type	Category	Load1	Load2	Position	Direction	Loc/Begin	Sp/End
Uniform (plf)	DL	162.50	162.50	TC	+	0-0	81-4 3/4
Uniform (plf)	LL	352.50	352.50	TC	+	0-0	81-4 3/4
Conc anywhere (lbs)	TL	315.00	0.00	BC	+	40-8 3/8	0-0
Conc anywhere (lbs)	TL	315.00	0.00	TC	+	40-8 3/8	0-0
Net Uplift (plf)	WL	250.00	250.00	TC	-	0-0	81-4 3/4
Conc Load (lbs)	LL	1,700.00	0.00	TC	+	19-11 1/2	25-11 1/2
Conc Load (lbs)	LL	1,700.00	0.00	TC	+	26-11 1/2	32-11 1/2
Conc Load (lbs)	LL	1,700.00	0.00	TC	+	48-11 1/2	54-11 1/2
Conc Load (lbs)	LL	1,700.00	0.00	TC	+	54-11 1/2	60-11 1/2
Conc Load (lbs)	LL	1,700.00	0.00	TC	+	72-11 1/2	78-11 1/2

Stress Analysis Summary

Int. Panel TC: 56.00	Max Panel BC: 112.00	Reaction LE: 25,325.68	Reaction RE: 26,779.06	Minimum Shear: 6,694.76	Max TC Comp.: 114,280.76	Max BC Tension 115,461.19
--------------------------------	--------------------------------	----------------------------------	----------------------------------	-----------------------------------	------------------------------------	-------------------------------------

Member	TC Tension	TC Compression	BC Tension	BC Compression	Web Tension	Web Comp.	Web Length	PP Dist.
W2	15,997.01	41,112.49	0.00	0.00	49,165.00	18,626.65	109.89	0-2
V1S	15,426.09	39,550.72	0.00	0.00	1,695.94	10,142.16	59.78	6-4 1/4
W3	15,426.09	39,550.72	59,600.15	23,329.71	11,206.66	28,786.87	79.40	8-0 3/8
W4	29,837.49	76,273.75	59,600.15	23,329.71	24,787.73	9,227.47	79.40	12-8 3/8
W5	29,837.49	76,273.75	90,556.52	35,162.04	7,549.75	21,222.24	79.40	17-4 3/8
W6	39,303.35	102,354.08	90,556.52	35,162.04	17,832.24	5,872.03	79.40	22-0 3/8
V3	39,303.35	102,354.08	90,556.52	35,162.04	1,189.42	4,405.32	56.29	26-8 3/8
W7	39,303.35	102,354.08	110,164.01	42,261.43	4,194.31	12,464.20	79.40	26-8 3/8
W8	44,036.28	114,280.76	110,164.01	42,261.43	9,443.24	3,642.87	79.40	31-4 3/8
V4	44,036.28	114,280.76	110,164.01	42,261.43	1,189.42	3,604.74	56.29	36-0 3/8
W9	44,036.28	114,280.76	115,461.19	44,627.89	3,642.87	9,443.24	79.40	36-0 3/8

* Symmetrical Joist

Standard Verticals

Member	Position	Max Tension	Max Comp.	Length
V2	Interior	2,067.50	5,304.74	56.29

STRESS ANALYSIS - PAGE 2



NEW MILLENNIUM
BUILDING SYSTEMS

Job Number: 8010-0704	Job Name: 10-123 BARRHAVEN FIRE STATION - SHOPORDERS	Date Run: 11/19/2010 3:57:02 PM
Location: OTTAWA, ON		Joist Description: Deep Long Span 58DLH515/235
		Mark: J42

Chord Properties

Chord	Area	Rx	Rz	Ryy	Y	Ix	Q	Material
TC	1.6070	0.9260	0.5907	1.6920	0.8536	1.3780	1.0000	34 = 3 x 3 x .281
BC	1.6070	0.9260	0.5907	1.6920	0.8536	1.3780	1.0000	34 = 3 x 3 x .281

Axial and Bending Analysis

K: 0.75	Fy: 50,000.00	Fb: 45,000.00	Mom of Inertia: 5,095.25	LL 360: 357.36	LL 240: 536.04	Max Bridg TC: 23-11 5/8	Max Bridg BC: 16-11 7/8
-------------------	-------------------------	-------------------------	------------------------------------	--------------------------	--------------------------	-----------------------------------	-----------------------------------

Top Chord Check	End Panel LE	First Panel LE	Interior Panel	First Panel RE	End Panel RE	
Length	74.25	76.13	56.00	76.13	74.25	Gap Between Chords: 1.1250
Bending Load	499.74	499.74	499.74	499.74	499.74	Min Weld Len 2X: 0.8209
Axial Load	38,841.09	37,687.49	114,280.76	39,550.72	41,112.49	Max Load Fillers TC: 118,132.91
fa	12,084.68	11,725.76	35,556.31	12,305.46	12,791.38	Max Load no Fillers TC: 96,436.74
Maximum K L/r	80.18	82.21	47.40	82.21	80.18	TC OAL/Ryy: 574.9000
Fcr	31,247.35	30,505.07	42,424.75	30,505.07	31,247.35	BC Stress: 38,467.57
Fa	28,122.62	27,454.56	38,182.27	27,454.56	28,122.62	BC L/Rz: 189.6082
F'e	44,518.25	42,352.24	139,133.72	42,352.24	44,518.25	TC Shear Stress: 16,318.58
Cm	0.9095	0.9077	0.8864	0.9031	0.9042	BC Shear Stress: 16,318.58
Panel Point Moment	28500.70	27324.90	12516.55	27324.90	28500.70	
Mid Panel Moment	19834.95	11535.63	6819.73	11535.63	19834.95	
Panel Point fb	22195.59	21279.90	9747.56	21279.90	22195.59	
Mid Panel fb	6143.57	3572.98	2112.31	3572.98	6143.57	
Fillers	1	1	8	1	1	
Panel Point Stress	34,280.26	33,005.66	45,303.87	33,585.37	34,986.96	
Mid Panel Stress	0.5878	0.5196	0.9829	0.5423	0.6160	

Web Design

Member	Web Tension	Allow Tension	Web Comp	Allow Comp	Weld	Qty	Material
W2	49,165.00	74,296.57	18,626.65	19,028.03	11.77 x 0.188	2	20 = 2 x 2 x .216
W3	11,206.66	65,039.63	28,786.87	29,498.59	6.91 x 0.187	2	A36 = 2.0938 x .187
W4	24,787.73	33,914.79	9,227.47	9,458.19	8.56 x 0.130	2	09A = 1 1/2 x 1 1/2 x .130
W5	7,549.75	56,851.68	21,222.24	26,809.57	5.85 x 0.163	2	17 = 2 x 2 x .163
W6	17,832.24	28,425.84	5,872.03	6,282.29	4.91 x 0.163	1	17 = 2 x 2 x .163
W7	4,194.31	43,636.64	12,464.20	16,591.25	3.91 x 0.143	2	14 = 1 3/4 x 1 3/4 x .143
W8	9,443.24	36,889.49	3,642.87	4,413.76	2.26 x 0.188	1	C38 = 1.125 x 1.844 x .200
W9	3,642.87	33,914.79	9,443.24	9,458.19	3.26 x 0.130	2	09A = 1 1/2 x 1 1/2 x .130
V1	1,695.94	28,425.84	10,142.16	11,044.29	2.79 x 0.163	1	17 = 2 x 2 x .163
V2	2,067.50	16,459.83	5,304.74	3,838.63	2.00 x 0.134	1	C22 = 1.125 x 1.086 x .134

* Symmetrical Joist

STRESS ANALYSIS - PAGE 3



NEW MILLENNIUM
BUILDING SYSTEMS

Job Number: 8010-0704	Job Name: 10-123 BARRHAVEN FIRE STATION - SHOPORDERS	Date Run: 11/19/2010 3:57:02 PM
Location: OTTAWA, ON	Joist Description: Deep Long Span 58DLH515/235	Mark: J42

TCX Design

TCX Left		TCX Right	
TCX Length	0-0 1/2	TCX Length	0-0 1/2
TCX Type	R	TCX Type	R
TCX Depth	7	TCX Depth	7
BPL Length	0-6	BPL Length	0-6
Clear Bearing	0-11 3/8	Clear Bearing	0-8 1/2
BPL Material: 69L = 2 x 3 x .250		BPL Material: 69L = 2 x 3 x .250	
Total Load	515.00	Total Load	515.00
Reqd TL Def L/80	0.01	Reqd TL Def L/80	0.01
Live Load	352.50	Live Load	352.50
Reqd LL Def L/120	0.00	Reqd LL Def L/120	0.00
Section Modulus	1.2841	Section Modulus	1.2841
Reqd SM	0.0001	Reqd SM	0.0001
Mom of Inertia	2.7561	Mom of Inertia	2.7561
Reqd MI	0.0000	Reqd MI	0.0000
Seat Type: T-Plate		Seat Type: T-Plate	

LSD Design

- | | |
|--|--|
| Case 1a: DL | Case 6a: 1.25(DL)+0.5(CL+SL)+1.4(WL+AX)+0.8(TL) |
| Case 1b: 1.4(DL) | Case 6b: 1.25(DL)+0.5(CL+SL)+1.4(WL-AX)+0.8(TL) |
| Case 2a: LL | Case 6c: 1.25(DL)+0.5(CL+SL)+1.4(WL+AX+IP)+0.8(TL) |
| Case 2b: SL | Case 6d: 1.25(DL)+0.5(CL+SL)+1.4(WL-AX+IP)+0.8(TL) |
| Case 3a: 1.25(DL+CL)+1.5(TL+LL) | Case 7a: 1.25(DL+CL)+0.4(WL+AX)+1.5(TL+LL) |
| Case 3b: 1.25(DL+CL)+1.5(TL+SL) | Case 7b: 1.25(DL+CL)+0.4(WL-AX)+1.5(TL+LL) |
| Case 3c: 1.25(DL+CL)+1.5(TL+LL+FEM) | Case 7c: 1.25(DL+CL)+0.4(WL+AX+IP)+1.5(TL+LL) |
| Case 3d: 1.25(DL+CL)+1.5(TL+SL+FEM) | Case 7d: 1.25(DL+CL)+0.4(WL-AX+IP)+1.5(TL+LL) |
| Case 3e: DL+CL+TL+LL | Case 8a: 1.25(DL+CL)+0.4(WL+AX)+1.5(TL+SL) |
| Case 3f: DL+CL+TL+SL | Case 8b: 1.25(DL+CL)+0.4(WL-AX)+1.5(TL+SL) |
| Case 4a: 1.25(DL)+0.5(CL+LL)+1.4(WL+AX)+0.8(TL) | Case 8c: 1.25(DL+CL)+0.4(WL+AX+IP)+1.5(TL+SL) |
| Case 4b: 1.25(DL)+0.5(CL+LL)+1.4(WL-AX)+0.8(TL) | Case 8d: 1.25(DL+CL)+0.4(WL-AX+IP)+1.5(TL+SL) |
| Case 4c: 1.25(DL)+0.5(CL+LL)+1.4(WL+AX+IP)+0.8(TL) | Case 9a: DL+CL+0.5(LL)+0.7(TL)+SM+AX+FEM |
| Case 4d: 1.25(DL)+0.5(CL+LL)+1.4(WL-AX+IP)+0.8(TL) | Case 9b: DL+CL+0.5(LL)+0.7(TL)+SM-AX+FEM |
| Case 4e: 1.25(DL+CL)+1.4(WL+AX)+1.1(TL)+LL | Case 9c: DL+CL+0.25(SL)+0.7(TL)+SM+AX+FEM |
| Case 4f: 1.25(DL+CL)+1.4(WL-AX)+1.1(TL)+LL | Case 9d: DL+CL+0.25(SL)+0.7(TL)+SM-AX+FEM |
| Case 5a: 0.9(DL)+1.4(WL+AX) | Case 9e: DL+CL+LL+1.1(TL)+SM+AX+FEM |
| Case 5b: 0.9(DL)+1.4(WL-AX) | Case 9f: DL+CL+LL+1.1(TL)+SM-AX+FEM |
| Case 5c: 0.9(DL)+1.4(WL+AX+IP) | Case 10a: DL+SM+AX |
| Case 5d: 0.9(DL)+1.4(WL-AX+IP) | Case 10b: DL+SM-AX |
| Case 5e: DL+SM+AX | Case 10c: DL+CL+SM+AX |
| Case 5f: DL+SM-AX | Case 10d: DL+CL+SM-AX |

STRESS ANALYSIS - PAGE 1



NEW MILLENNIUM
BUILDING SYSTEMS

Job Number: 8010-0704	Job Name: 10-123 BARRHAVEN FIRE STATION - SHOPORDERS	Date Run: 11/19/2010 3:57:03 PM
Location: OTTAWA, ON	Joist Description: Deep Long Span 58DLH515/235	Mark: J44

Geometry

Base Length: 81-4 3/4	Working Length: 81-0 3/4	Joist Depth: 58.00	Effective Depth: 56.03	BC Panel Length: 7 @ 9-4	Shape: Parallel Chords
---------------------------------	------------------------------------	------------------------------	----------------------------------	------------------------------------	----------------------------------

Variable	Left End	Right End
BC Panel	12-1	12-1
TC Panel	7-5	7-5
First Half	0-7 3/8	0-7 3/8
First Diag.	12-8 3/8	12-8 3/8
Depth	58.00	58.00

Deflection Case 2a: LL (Max Deflection: -3.20 in-Y, -0.51 in-X)

Loads, *** All loads are factored ***

Load Type	Category	Load1	Load2	Position	Direction	Loc/Begin	Sp/End
Uniform (plf)	DL	162.50	162.50	TC	+	0-0	81-4 3/4
Uniform (plf)	LL	352.50	352.50	TC	+	0-0	81-4 3/4
Conc anywhere (lbs)	TL	315.00	0.00	BC	+	40-8 3/8	0-0
Conc anywhere (lbs)	TL	315.00	0.00	TC	+	40-8 3/8	0-0
Net Uplift (plf)	WL	250.00	250.00	TC	-	0-0	81-4 3/4
Conc Load (lbs)	LL	3,375.00	0.00	TC	+	7-4	7-4
Conc Load (lbs)	LL	3,375.00	0.00	TC	+	22-10	22-10
Conc Load (lbs)	LL	3,375.00	0.00	TC	+	25-8 1/2	25-8 1/2
Conc Load (lbs)	LL	3,375.00	0.00	TC	+	41-2 1/4	41-2 1/4
Conc Load (lbs)	LL	3,375.00	0.00	TC	+	44-1	44-1
Uniform (plf)	LL	245.00	245.00	TC	+	52-6 1/2	81-5 1/4
Conc Load (lbs)	LL	3,375.00	0.00	TC	+	59-6 7/8	59-6 7/8

Stress Analysis Summary

Int. Panel TC: 56.00	Max Panel BC: 112.00	Reaction LE: 34,905.35	Reaction RE: 35,989.49	Minimum Shear: 8,997.37	Max TC Comp.: 159,659.08	Max BC Tension: 161,684.11
--------------------------------	--------------------------------	----------------------------------	----------------------------------	-----------------------------------	------------------------------------	--------------------------------------

Member	TC Tension	TC Compression	BC Tension	BC Compression	Web Tension	Web Comp.	Web Length	PP Dist.
W2	24,007.96	84,024.69	0.00	0.00	91,102.08	25,784.96	153.58	0-2
V1S	22,411.82	79,265.21	0.00	0.00	2,257.86	10,882.94	79.22	7-5
W3	22,411.82	79,265.21	82,971.85	23,439.79	7,876.90	28,620.16	56.51	12-1
W4	29,978.27	107,338.85	82,971.85	23,439.79	34,774.04	9,249.15	79.22	12-8 3/8
W5	29,978.27	107,338.85	128,010.41	35,327.93	7,567.49	30,118.79	79.22	17-4 3/8
W6	39,488.79	141,914.39	128,010.41	35,327.93	21,757.34	5,885.82	79.22	22-0 3/8
V3	39,488.79	141,914.39	128,010.41	35,327.93	1,189.42	7,071.03	56.03	26-8 3/8
W7	39,488.79	141,914.39	152,273.48	42,460.82	4,204.16	14,755.41	79.22	26-8 3/8
W8	44,244.04	159,659.08	152,273.48	42,460.82	12,720.99	3,651.42	79.22	31-4 3/8
V4	44,244.04	159,659.08	152,273.48	42,460.82	1,189.42	3,831.63	56.03	36-0 3/8
W9	44,244.04	159,659.08	161,684.11	44,838.44	3,651.42	12,720.99	79.22	36-0 3/8

* Symmetrical Joist

Standard Verticals

Member	Position	Max Tension	Max Comp.	Length
V2	Interior	1,189.42	7,071.03	56.03

STRESS ANALYSIS - PAGE 2



Job Number: 8010-0704	Job Name: 10-123 BARRHAVEN FIRE STATION - SHOPORDERS	Date Run: 11/19/2010 3:57:03 PM
Location: OTTAWA, ON	Joist Description: Deep Long Span 58DLH515/235	Mark: J44

Chord Properties

Chord	Area	Rx	Rz	Ryy	Y	Ix	Q	Material
TC	2.0930	1.0824	0.6899	1.8930	0.9905	2.4522	0.9871	38 = 3 1/2 x 3 1/2 x .313
BC	1.9266	1.0861	0.6914	1.8874	0.9811	2.2726	0.9552	37 = 3 1/2 x 3 1/2 x .287

Axial and Bending Analysis

K: 0.75	Fy: 50,000.00	Fb: 45,000.00	Mom of Inertia: 6,303.13	LL 360: 442.08	LL 240: 663.11	Max Bridg TC: 26-9 7/8	Max Bridg BC: 21-5 3/8
-------------------	-------------------------	-------------------------	------------------------------------	--------------------------	--------------------------	----------------------------------	----------------------------------

Top Chord Check	End Panel LE	First Panel LE	Interior Panel	First Panel RE	End Panel RE	Gap Between Chords: 1.1250
Length	87.00	63.38	56.00	63.38	87.00	Min Weld Len 2X: 1.1469
Bending Load	499.74	499.74	499.74	729.43	729.43	Max Load Fillers TC: 162,466.98
Axial Load	83,430.34	76,870.66	159,659.08	79,265.21	84,024.69	Max Load no Fillers TC: 140,145.23
fa	19,930.51	18,363.48	38,140.64	18,935.51	20,072.49	TC OAL/Ryy: 513.8587
Maximum K L/r	80.38	91.86	40.58	91.86	80.38	BC Stress: 43,770.70
Fcr	30,962.78	26,844.08	43,824.02	26,844.08	30,962.78	BC L/Rz: 161.9966
Fa	27,866.50	24,159.67	39,441.62	24,159.67	27,866.50	TC Shear Stress: 18,241.13
F'e	44,304.26	83,492.61	190,101.45	83,492.61	44,304.26	BC Shear Stress: 19,869.89
Cm	0.8500	0.9267	0.9108	0.9244	0.8490	
Panel Point Moment	33201.07	31535.56	12516.55	45279.06	46945.76	
Mid Panel Moment	28846.94	4711.13	6819.73	6243.02	40736.01	
Panel Point fb	16987.90	16135.72	6404.31	23167.82	24020.62	
Mid Panel fb	5826.15	951.49	1377.37	1260.89	8227.35	
Fillers	1	0	8	0	1	
Panel Point Stress	36,918.41	34,499.20	44,544.95	42,103.33	44,093.11	
Mid Panel Stress	0.9134	0.7834	0.9993	0.8149	1.0018	

Web Design

Member	Web Tension	Allow Tension	Web Comp	Allow Comp	Weld	Qty	Material
W2	91,102.08	119,121.80	25,784.96	35,750.04	18.02 x 0.227	2	32 = 3 x 3 x .227
W3	7,876.90	47,129.38	28,620.16	28,620.46	8.29 x 0.155	2	15 = 1 3/4 x 1 3/4 x .155
W4	34,774.04	35,653.80	9,249.15	9,964.70	11.40 x 0.137	2	10 = 1 1/2 x 1 1/2 x .137
W5	7,567.49	74,296.57	30,118.79	35,277.99	7.21 x 0.188	2	20 = 2 x 2 x .216
W6	21,757.34	28,425.84	5,885.82	6,312.01	5.99 x 0.163	1	17 = 2 x 2 x .163
W7	4,204.16	43,636.64	14,755.41	16,663.27	4.63 x 0.143	2	14 = 1 3/4 x 1 3/4 x .143
W8	12,720.99	36,889.49	3,651.42	4,432.26	3.05 x 0.188	1	C38 = 1.125 x 1.844 x .200
W9	3,651.42	43,636.64	12,720.99	16,663.27	3.99 x 0.143	2	14 = 1 3/4 x 1 3/4 x .143
V1	2,257.86	40,084.63	10,882.94	11,135.88	3.15 x 0.155	2	12 = 1 1/2 x 1 1/2 x .155
V2	1,189.42	16,459.83	7,071.03	3,869.68	2.00 x 0.134	1	C22 = 1.125 x 1.086 x .134

* Symmetrical Joist

STRESS ANALYSIS - PAGE 3



NEW MILLENNIUM
BUILDING SYSTEMS

Job Number: 8010-0704	Job Name: 10-123 BARRHAVEN FIRE STATION - SHOPORDERS	Date Run: 11/19/2010 3:57:03 PM
Location: OTTAWA, ON	Joist Description: Deep Long Span 58DLH515/235	Mark: J44

TCX Design

TCX Left		TCX Right	
TCX Length	0-0 1/2	TCX Length	0-0 1/2
TCX Type	R	TCX Type	R
TCX Depth	7	TCX Depth	7
BPL Length	0-6	BPL Length	0-6
Clear Bearing	1-0 3/4	Clear Bearing	0-8 1/2
BPL Material: 69L = 2 x 3 x .250		BPL Material: 69L = 2 x 3 x .250	

Total Load	515.00	Total Load	515.00
Reqd TL Def L/80	0.01	Reqd TL Def L/80	0.01
Live Load	352.50	Live Load	352.50
Reqd LL Def L/120	0.00	Reqd LL Def L/120	0.00
Section Modulus	1.9544	Section Modulus	1.9544
Reqd SM	0.0001	Reqd SM	0.0001
Mom of Inertia	4.9045	Mom of Inertia	4.9045
Reqd MI	0.0000	Reqd MI	0.0000

Seat Type: T-Plate

Seat Type: T-Plate

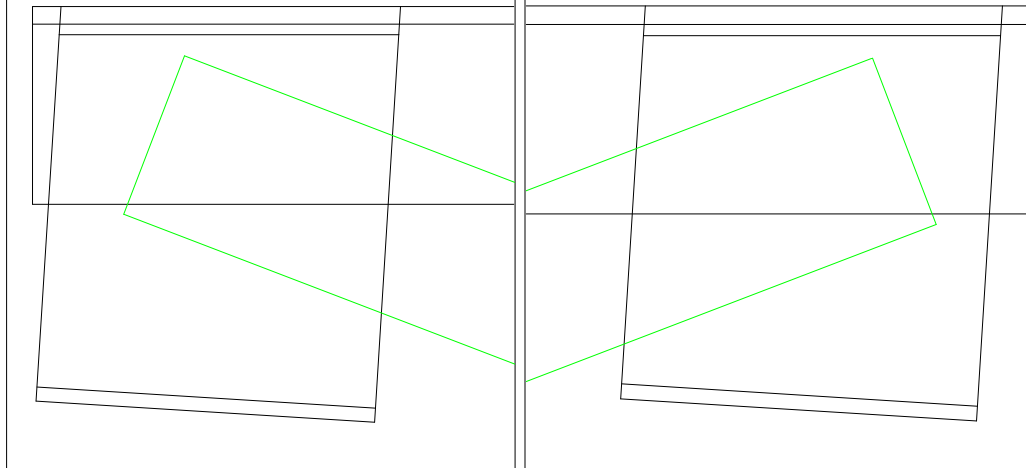

LSD Design

- | | |
|--|--|
| Case 1a: DL | Case 6a: 1.25(DL)+0.5(CL+SL)+1.4(WL+AX)+0.8(TL) |
| Case 1b: 1.4(DL) | Case 6b: 1.25(DL)+0.5(CL+SL)+1.4(WL-AX)+0.8(TL) |
| Case 2a: LL | Case 6c: 1.25(DL)+0.5(CL+SL)+1.4(WL+AX+IP)+0.8(TL) |
| Case 2b: SL | Case 6d: 1.25(DL)+0.5(CL+SL)+1.4(WL-AX+IP)+0.8(TL) |
| Case 3a: 1.25(DL+CL)+1.5(TL+LL) | Case 7a: 1.25(DL+CL)+0.4(WL+AX)+1.5(TL+LL) |
| Case 3b: 1.25(DL+CL)+1.5(TL+SL) | Case 7b: 1.25(DL+CL)+0.4(WL-AX)+1.5(TL+LL) |
| Case 3c: 1.25(DL+CL)+1.5(TL+LL+FEM) | Case 7c: 1.25(DL+CL)+0.4(WL+AX+IP)+1.5(TL+LL) |
| Case 3d: 1.25(DL+CL)+1.5(TL+SL+FEM) | Case 7d: 1.25(DL+CL)+0.4(WL-AX+IP)+1.5(TL+LL) |
| Case 3e: DL+CL+TL+LL | Case 8a: 1.25(DL+CL)+0.4(WL+AX)+1.5(TL+SL) |
| Case 3f: DL+CL+TL+SL | Case 8b: 1.25(DL+CL)+0.4(WL-AX)+1.5(TL+SL) |
| Case 4a: 1.25(DL)+0.5(CL+LL)+1.4(WL+AX)+0.8(TL) | Case 8c: 1.25(DL+CL)+0.4(WL+AX+IP)+1.5(TL+SL) |
| Case 4b: 1.25(DL)+0.5(CL+LL)+1.4(WL-AX)+0.8(TL) | Case 8d: 1.25(DL+CL)+0.4(WL-AX+IP)+1.5(TL+SL) |
| Case 4c: 1.25(DL)+0.5(CL+LL)+1.4(WL+AX+IP)+0.8(TL) | Case 9a: DL+CL+0.5(LL)+0.7(TL)+SM+AX+FEM |
| Case 4d: 1.25(DL)+0.5(CL+LL)+1.4(WL-AX+IP)+0.8(TL) | Case 9b: DL+CL+0.5(LL)+0.7(TL)+SM-AX+FEM |
| Case 4e: 1.25(DL+CL)+1.4(WL+AX)+1.1(TL)+LL | Case 9c: DL+CL+0.25(SL)+0.7(TL)+SM+AX+FEM |
| Case 4f: 1.25(DL+CL)+1.4(WL-AX)+1.1(TL)+LL | Case 9d: DL+CL+0.25(SL)+0.7(TL)+SM-AX+FEM |
| Case 5a: 0.9(DL)+1.4(WL+AX) | Case 9e: DL+CL+LL+1.1(TL)+SM+AX+FEM |
| Case 5b: 0.9(DL)+1.4(WL-AX) | Case 9f: DL+CL+LL+1.1(TL)+SM-AX+FEM |
| Case 5c: 0.9(DL)+1.4(WL+AX+IP) | Case 10a: DL+SM+AX |
| Case 5d: 0.9(DL)+1.4(WL-AX+IP) | Case 10b: DL+SM-AX |
| Case 5e: DL+SM+AX | Case 10c: DL+CL+SM+AX |
| Case 5f: DL+SM-AX | Case 10d: DL+CL+SM-AX |

STRESS ANALYSIS - PAGE 1



NEW MILLENNIUM
BUILDING SYSTEMS

Job Number: 8010-0704	Job Name: 10-123 BARRHAVEN FIRE STATION - SHOPORDERS	Date Run: 11/19/2010 4:15:07 PM
Location: OTTAWA, ON	Joist Description: Deep Long Span 58DLH515/235	Mark: J46

Geometry

Base Length: 81-4 3/4	Working Length: 81-0 3/4	Joist Depth: 58.00	Effective Depth: 54.88	BC Panel Length: 7 @ 9-4	Shape: Parallel Chords
---------------------------------	------------------------------------	------------------------------	----------------------------------	------------------------------------	----------------------------------

Variable	Left End	Right End	Deflection Case 2a: LL (Max Deflection: -1.57 in-Y, -0.18 in-X)
BC Panel	12-1	12-1	
TC Panel	7-5	7-5	
First Half	0-7 3/8	0-7 3/8	
First Diag.	12-8 3/8	12-8 3/8	
Depth	58.00	58.00	

Loads, *** All loads are factored ***

Load Type	Category	Load1	Load2	Position	Direction	Loc/Begin	Sp/End
Uniform (plf)	DL	162.50	162.50	TC	+	0-0	81-4 3/4
Uniform (plf)	LL	352.50	352.50	TC	+	0-0	81-4 3/4
Conc anywhere (lbs)	TL	315.00	0.00	BC	+	40-8 3/8	0-0
Conc anywhere (lbs)	TL	315.00	0.00	TC	+	40-8 3/8	0-0
Net Uplift (plf)	WL	250.00	250.00	TC	-	0-0	81-4 3/4
Conc Load (lbs)	LL	3,375.00	0.00	TC	+	7-4	7-4
Conc Load (lbs)	LL	3,375.00	0.00	TC	+	22-10	22-10
Conc Load (lbs)	LL	3,375.00	0.00	TC	+	25-8 1/2	25-8 1/2
Conc Load (lbs)	LL	3,375.00	0.00	TC	+	41-2 1/4	41-2 1/4
Conc Load (lbs)	LL	3,375.00	0.00	TC	+	44-1	44-1
Uniform (plf)	LL	0.00	500.00	TC	+	52-6 1/2	68-3
Conc Load (lbs)	LL	3,375.00	0.00	TC	+	59-6 7/8	59-6 7/8

Stress Analysis Summary

Int. Panel TC: 56.00	Max Panel BC: 112.00	Reaction LE: 34,508.52	Reaction RE: 33,409.50	Minimum Shear: 8,627.13	Max TC Comp.: 159,075.22	Max BC Tension: 161,547.53
--------------------------------	--------------------------------	----------------------------------	----------------------------------	-----------------------------------	------------------------------------	--------------------------------------

Member	TC Tension	TC Compression	BC Tension	BC Compression	Web Tension	Web Comp.	Web Length	PP Dist.
W2	24,509.88	84,140.59	0.00	0.00	90,992.63	26,252.93	153.17	0-2
V1S	22,880.37	78,080.34	0.00	0.00	2,281.57	10,985.93	78.41	7-5
W3	22,880.37	78,080.34	81,843.41	23,929.83	7,879.73	28,472.26	55.37	12-1
W4	30,605.00	106,687.27	81,843.41	23,929.83	35,093.63	9,346.28	78.41	12-8 3/8
W5	30,605.00	106,687.27	127,139.37	36,066.51	7,646.96	29,868.14	78.41	17-4 3/8
W6	40,314.36	140,880.59	127,139.37	36,066.51	21,418.88	5,947.63	78.41	22-0 3/8
V3	40,314.36	140,880.59	127,139.37	36,066.51	1,189.42	7,068.11	54.88	26-8 3/8
W7	40,314.36	140,880.59	151,130.28	43,348.53	4,248.31	14,764.76	78.41	26-8 3/8
W8	45,169.02	159,075.22	151,130.28	43,348.53	12,325.61	3,689.77	78.41	31-4 3/8
V4	45,169.02	159,075.22	151,130.28	43,348.53	1,189.42	3,828.71	54.88	36-0 3/8
W9	45,169.02	159,075.22	161,547.53	45,775.86	3,689.77	12,325.61	78.41	36-0 3/8

* Symmetrical Joist

Standard Verticals

Member	Position	Max Tension	Max Comp.	Length
V2	Interior	1,189.42	7,068.11	54.88

STRESS ANALYSIS - PAGE 2



Job Number: 8010-0704	Job Name: 10-123 BARRHAVEN FIRE STATION - SHOPORDERS	Date Run: 11/19/2010 4:15:07 PM
Location: OTTAWA, ON		Joist Description: Deep Long Span 58DLH515/235
		Mark: J46

Chord Properties

Chord	Area	Rx	Rz	Ryy	Y	Ix	Q	Material
TC	5.7500	1.8607	1.1847	2.9176	1.6848	19.9078	0.9613	50 = 6 x 6 x .500
BC	4.7500	1.5390	0.9829	2.5210	1.4342	11.2503	1.0000	47 = 5 x 5 x .500

Axial and Bending Analysis

K: 0.75	Fy: 50,000.00	Fb: 45,000.00	Mom of Inertia: 15,700.34	LL 300: 1,321.39	TL 489: 810.67	Max Bridg TC: 41-4	Max Bridg BC: 45-5 3/4
-------------------	-------------------------	-------------------------	-------------------------------------	----------------------------	--------------------------	------------------------------	----------------------------------

Top Chord Check	End Panel LE	First Panel LE	Interior Panel	First Panel RE	End Panel RE	Gap Between Chords: 1.1250
Length	87.00	63.38	56.00	63.38	87.00	Min Weld Len 2X: 1.1427
Bending Load	499.74	499.74	499.74	499.74	499.74	Max Load Fillers TC: 484,563.25
Axial Load	84,140.59	77,443.77	159,075.22	78,080.34	81,372.94	Max Load no Fillers TC: 461,365.13
fa	7,316.57	6,734.24	13,832.63	6,789.60	7,075.91	TC OAL/Ryy: 333.4052
Maximum K L/r	73.43	53.49	35.45	53.49	73.43	BC Stress: 17,522.69
Fcr	32,902.23	39,308.54	44,001.90	39,308.54	32,902.23	BC L/Rz: 113.9466
Fa	29,612.01	35,377.68	39,601.71	35,377.68	29,612.01	TC Shear Stress: 6,570.27
F'e	130,922.84	246,727.73	561,765.81	246,727.73	130,922.84	BC Shear Stress: 7,906.25
Cm	0.9814	0.9909	0.9891	0.9908	0.9820	
Panel Point Moment	33201.07	31535.56	12516.55	31535.56	33201.07	
Mid Panel Moment	28846.94	4711.13	6819.73	4711.13	28846.94	
Panel Point fb	3598.33	3417.82	1356.54	3417.82	3598.33	
Mid Panel fb	1220.65	199.35	288.57	199.35	1220.65	
Fillers	0	0	0	0	0	
Panel Point Stress	10,914.90	10,152.06	15,189.17	10,207.42	10,674.24	
Mid Panel Stress	0.2733	0.0999	0.3553	0.1007	0.2652	

Web Design

Member	Web Tension	Allow Tension	Web Comp	Allow Comp	Weld	Qty	Material
W2	90,992.63	119,121.80	26,252.93	35,943.95	21.79 x 0.188	2	32 = 3 x 3 x .227
W3	7,879.73	47,129.38	28,472.26	29,175.87	8.25 x 0.155	2	15 = 1 3/4 x 1 3/4 x .155
W4	35,093.63	42,291.04	9,346.28	9,395.65	8.40 x 0.188	1	22 = 2 x 2 x .248
W5	7,646.96	65,039.63	29,868.14	30,084.91	7.17 x 0.187	2	A36 = 2.0938 x .187
W6	21,418.88	28,425.84	5,947.63	6,442.66	5.90 x 0.163	1	17 = 2 x 2 x .163
W7	4,248.31	43,636.64	14,764.76	16,975.48	4.64 x 0.143	2	14 = 1 3/4 x 1 3/4 x .143
W8	12,325.61	36,889.49	3,689.77	4,513.32	2.95 x 0.188	1	C38 = 1.125 x 1.844 x .200
W9	3,689.77	43,636.64	12,325.61	16,975.48	3.87 x 0.143	2	14 = 1 3/4 x 1 3/4 x .143
V1	2,281.57	40,084.63	10,985.93	11,366.38	3.18 x 0.155	2	12 = 1 1/2 x 1 1/2 x .155
V2	1,189.42	16,459.83	7,068.11	4,008.67	2.00 x 0.134	1	C22 = 1.125 x 1.086 x .134

* Symmetrical Joist

STRESS ANALYSIS - PAGE 3



NEW MILLENNIUM
BUILDING SYSTEMS

Job Number: 8010-0704	Job Name: 10-123 BARRHAVEN FIRE STATION - SHOPORDERS	Date Run: 11/19/2010 4:15:07 PM
Location: OTTAWA, ON	Joist Description: Deep Long Span 58DLH515/235	Mark: J46

TCX Design

TCX Left		TCX Right	
TCX Length	0-0 1/2	TCX Length	0-0 1/2
TCX Type	R	TCX Type	R
TCX Depth	7	TCX Depth	7
BPL Length	0-6 1/2	BPL Length	0-6 1/2
Clear Bearing	1-0 1/2	Clear Bearing	0-8 3/8
BPL Material: 50 = 6 x 6 x .500		BPL Material: 50 = 6 x 6 x .500	

Total Load	515.00	Total Load	515.00
Reqd TL Def L/80	0.01	Reqd TL Def L/80	0.01
Live Load	352.50	Live Load	352.50
Reqd LL Def L/120	0.00	Reqd LL Def L/120	0.00
Section Modulus	9.2268	Section Modulus	9.2268
Reqd SM	0.0001	Reqd SM	0.0001
Mom of Inertia	39.8157	Mom of Inertia	39.8157
Reqd MI	0.0000	Reqd MI	0.0000

Seat Type: Lapped

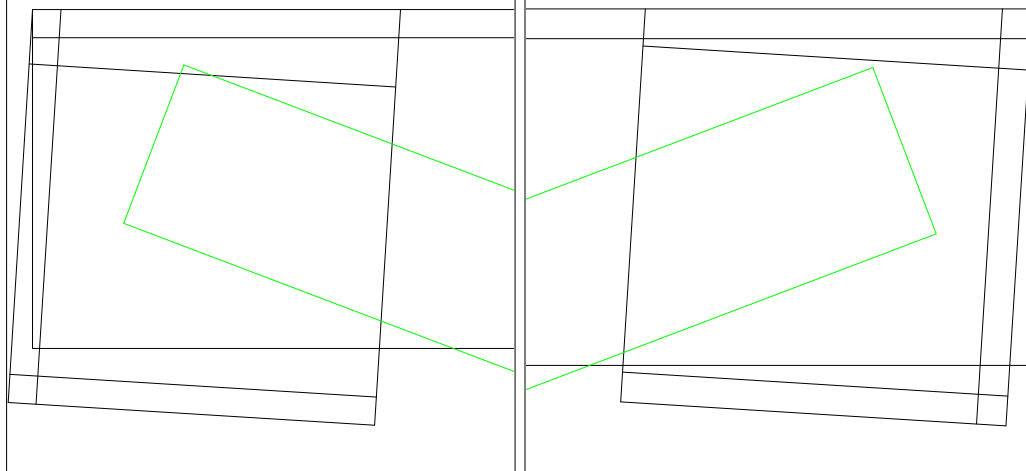

LSD Design

- | | |
|--|--|
| Case 1a: DL | Case 6a: 1.25(DL)+0.5(CL+SL)+1.4(WL+AX)+0.8(TL) |
| Case 1b: 1.4(DL) | Case 6b: 1.25(DL)+0.5(CL+SL)+1.4(WL-AX)+0.8(TL) |
| Case 2a: LL | Case 6c: 1.25(DL)+0.5(CL+SL)+1.4(WL+AX+IP)+0.8(TL) |
| Case 2b: SL | Case 6d: 1.25(DL)+0.5(CL+SL)+1.4(WL-AX+IP)+0.8(TL) |
| Case 3a: 1.25(DL+CL)+1.5(TL+LL) | Case 7a: 1.25(DL+CL)+0.4(WL+AX)+1.5(TL+LL) |
| Case 3b: 1.25(DL+CL)+1.5(TL+SL) | Case 7b: 1.25(DL+CL)+0.4(WL-AX)+1.5(TL+LL) |
| Case 3c: 1.25(DL+CL)+1.5(TL+LL+FEM) | Case 7c: 1.25(DL+CL)+0.4(WL+AX+IP)+1.5(TL+LL) |
| Case 3d: 1.25(DL+CL)+1.5(TL+SL+FEM) | Case 7d: 1.25(DL+CL)+0.4(WL-AX+IP)+1.5(TL+LL) |
| Case 3e: DL+CL+TL+LL | Case 8a: 1.25(DL+CL)+0.4(WL+AX)+1.5(TL+SL) |
| Case 3f: DL+CL+TL+SL | Case 8b: 1.25(DL+CL)+0.4(WL-AX)+1.5(TL+SL) |
| Case 4a: 1.25(DL)+0.5(CL+LL)+1.4(WL+AX)+0.8(TL) | Case 8c: 1.25(DL+CL)+0.4(WL+AX+IP)+1.5(TL+SL) |
| Case 4b: 1.25(DL)+0.5(CL+LL)+1.4(WL-AX)+0.8(TL) | Case 8d: 1.25(DL+CL)+0.4(WL-AX+IP)+1.5(TL+SL) |
| Case 4c: 1.25(DL)+0.5(CL+LL)+1.4(WL+AX+IP)+0.8(TL) | Case 9a: DL+CL+0.5(LL)+0.7(TL)+SM+AX+FEM |
| Case 4d: 1.25(DL)+0.5(CL+LL)+1.4(WL-AX+IP)+0.8(TL) | Case 9b: DL+CL+0.5(LL)+0.7(TL)+SM-AX+FEM |
| Case 4e: 1.25(DL+CL)+1.4(WL+AX)+1.1(TL)+LL | Case 9c: DL+CL+0.25(SL)+0.7(TL)+SM+AX+FEM |
| Case 4f: 1.25(DL+CL)+1.4(WL-AX)+1.1(TL)+LL | Case 9d: DL+CL+0.25(SL)+0.7(TL)+SM-AX+FEM |
| Case 5a: 0.9(DL)+1.4(WL+AX) | Case 9e: DL+CL+LL+1.1(TL)+SM+AX+FEM |
| Case 5b: 0.9(DL)+1.4(WL-AX) | Case 9f: DL+CL+LL+1.1(TL)+SM-AX+FEM |
| Case 5c: 0.9(DL)+1.4(WL+AX+IP) | Case 10a: DL+SM+AX |
| Case 5d: 0.9(DL)+1.4(WL-AX+IP) | Case 10b: DL+SM-AX |
| Case 5e: DL+SM+AX | Case 10c: DL+CL+SM+AX |
| Case 5f: DL+SM-AX | Case 10d: DL+CL+SM-AX |

STRESS ANALYSIS - PAGE 1



NEW MILLENNIUM
BUILDING SYSTEMS

Job Number: 8010-0704	Job Name: 10-123 BARRHAVEN FIRE STATION - SHOPORDERS	Date Run: 11/19/2010 4:15:50 PM
Location: OTTAWA, ON	Joist Description: Deep Long Span 58DLH515/235	Mark: J48

Geometry

Base Length: 68-2 1/2	Working Length: 67-10 1/2	Joist Depth: 58.00	Effective Depth: 54.61	BC Panel Length: 6 @ 9-4	Shape: Parallel Chords
---------------------------------	-------------------------------------	------------------------------	----------------------------------	------------------------------------	----------------------------------

Variable	Left End	Right End
BC Panel	6-1 1/4	6-1 1/4
TC Panel	5-4 5/8	5-4 5/8
First Half	4-8	4-8
First Diag.	10-9 1/4	10-9 1/4
Depth	58.00	58.00

Deflection Case 2a: LL (Max Deflection: -0.77 in-Y, -0.09 in-X)

Loads, *** All loads are factored ***

Load Type	Category	Load1	Load2	Position	Direction	Loc/Begin	Sp/End
Uniform (plf)	DL	162.50	162.50	TC	+	0-0	68-2 1/2
Uniform (plf)	LL	352.50	352.50	TC	+	0-0	68-2 1/2
Net Uplift (plf)	WL	250.00	250.00	TC	-	0-0	68-2 1/2
Conc Load (lbs)	LL	3,375.00	0.00	TC	+	7-4	7-4
Conc Load (lbs)	LL	3,375.00	0.00	TC	+	22-10	22-10
Conc Load (lbs)	LL	3,375.00	0.00	TC	+	25-8 1/2	25-8 1/2
Conc anywhere (lbs)	TL	315.00	0.00	BC	+	34-1 1/4	0-0
Conc anywhere (lbs)	TL	315.00	0.00	TC	+	34-1 1/4	0-0
Conc Load (lbs)	LL	3,375.00	0.00	TC	+	41-2 1/4	41-2 1/4
Conc Load (lbs)	LL	3,375.00	0.00	TC	+	44-1	44-1
Uniform (plf)	LL	0.00	500.00	TC	+	52-6 1/2	68-3
Conc Load (lbs)	LL	3,375.00	0.00	TC	+	59-6 7/8	59-6 7/8

Stress Analysis Summary

Int. Panel TC: 56.00	Max Panel BC: 112.00	Reaction LE: 28,902.71	Reaction RE: 32,540.32	Minimum Shear: 8,135.08	Max TC Comp.: 113,621.27	Max BC Tension: 112,757.67
--------------------------------	--------------------------------	----------------------------------	----------------------------------	-----------------------------------	------------------------------------	--------------------------------------

Member	TC Tension	TC Compression	BC Tension	BC Compression	Web Tension	Web Comp.	Web Length	PP Dist.
W2	10,418.19	38,705.07	0.00	0.00	49,279.41	13,126.12	89.77	0-2
V1S	10,204.75	37,754.18	0.00	0.00	1,368.12	7,251.53	55.28	5-4 5/8
W3	10,204.75	37,754.18	62,001.11	17,007.27	9,501.37	34,174.77	78.22	6-1 1/4
W4	22,496.11	80,275.32	62,001.11	17,007.27	26,881.38	7,666.50	78.22	10-9 1/4
W5	22,496.11	80,275.32	95,524.84	26,765.20	5,962.84	23,315.75	78.22	15-5 1/4
W6	29,814.55	107,760.76	95,524.84	26,765.20	17,866.27	4,259.17	78.22	20-1 1/4
V3	29,814.55	107,760.76	95,524.84	26,765.20	1,189.42	8,272.20	54.61	24-9 1/4
W7	29,814.55	107,760.76	112,757.67	31,644.17	3,097.40	11,652.33	78.22	24-9 1/4
W8	32,254.04	113,621.27	112,757.67	31,644.17	11,652.33	4,602.72	78.22	29-5 1/4
V4	32,254.04	113,621.27	112,757.67	31,644.17	1,189.42	3,601.44	54.61	34-1 1/4

* Symmetrical Joist

Standard Verticals

Member	Position	Max Tension	Max Comp.	Length
V2	Interior	1,189.42	8,272.20	54.61

STRESS ANALYSIS - PAGE 2



Job Number: 8010-0704	Job Name: 10-123 BARRHAVEN FIRE STATION - SHOPORDERS	Date Run: 11/19/2010 4:15:50 PM
Location: OTTAWA, ON		Joist Description: Deep Long Span 58DLH515/235
		Mark: J48

Chord Properties

Chord	Area	Rx	Rz	Ryy	Y	Ix	Q	Material
TC	6.4336	1.8520	1.1814	2.9296	1.7075	22.0655	1.0000	51 = 6 x 6 x .5625
BC	5.7500	1.8607	1.1847	2.9176	1.6848	19.9078	0.9613	50 = 6 x 6 x .500

Axial and Bending Analysis

K: 0.75	Fy: 50,000.00	Fb: 45,000.00	Mom of Inertia: 18,150.55	LL 300: 2,602.21	TL 820: 952.03	Max Bridg TC: 41-6	Max Bridg BC: 58-4 1/4
-------------------	-------------------------	-------------------------	-------------------------------------	----------------------------	--------------------------	------------------------------	----------------------------------

Top Chord Check	End Panel LE	First Panel LE	Interior Panel	First Panel RE	End Panel RE	
Length	62.63	64.63	56.00	64.63	62.63	Gap Between Chords: 1.1250
Bending Load	499.74	499.74	499.74	801.33	934.30	Min Weld Len 2X: 0.8162
Axial Load	35,552.80	34,781.27	113,621.27	37,754.18	38,705.07	Max Load Fillers TC: 563,434.13
fa	2,763.06	2,703.10	8,830.31	2,934.14	3,008.04	Max Load no Fillers TC: 535,244.25
Maximum K L/r	53.01	54.70	35.55	54.70	53.01	TC OAL/Ryy: 278.0245
Fcr	40,713.14	40,173.90	45,586.21	40,173.90	40,713.14	BC Stress: 10,159.06
Fa	36,641.83	36,156.51	41,027.59	36,156.51	36,641.83	BC L/Rz: 94.5348
F'e	250,301.23	235,048.42	556,493.19	235,048.42	250,301.23	TC Shear Stress: 4,693.94
Cm	0.9963	0.9962	0.9929	0.9958	0.9960	BC Shear Stress: 5,277.68
Panel Point Moment	20431.48	19693.29	12516.55	30592.51	36134.94	
Mid Panel Moment	14529.54	8233.17	6819.73	12370.19	25299.10	
Panel Point fb	1987.32	1915.52	1217.45	2975.66	3514.76	
Mid Panel fb	562.16	318.55	263.86	478.62	978.85	
Fillers	0	0	0	0	0	
Panel Point Stress	4,750.38	4,618.62	10,047.76	5,909.80	6,522.80	
Mid Panel Stress	0.0503	0.0445	0.2205	0.0513	0.0630	

Web Design

Member	Web Tension	Allow Tension	Web Comp	Allow Comp	Weld	Qty	Material
W2	49,279.41	51,226.85	13,126.12	14,707.33	13.41 x 0.165	2	A32 = 1.8750 x .165
W3	9,501.37	74,296.57	34,174.77	35,942.28	8.18 x 0.188	2	20 = 2 x 2 x .216
W4	26,881.38	37,148.29	7,666.50	8,345.97	6.44 x 0.188	1	20 = 2 x 2 x .216
W5	5,962.84	56,851.68	23,315.75	27,374.29	6.42 x 0.163	2	17 = 2 x 2 x .163
W6	17,866.27	36,889.49	4,259.17	4,532.81	4.28 x 0.188	1	C38 = 1.125 x 1.844 x .200
W7	3,097.40	43,636.64	11,652.33	17,049.73	3.66 x 0.143	2	14 = 1 3/4 x 1 3/4 x .143
W8	11,652.33	41,419.47	4,602.72	5,006.48	2.79 x 0.188	1	C40 = 1.125 x 2.006 x .209
V1	1,368.12	36,889.49	7,251.53	8,136.06	2.00 x 0.188	1	C38 = 1.125 x 1.844 x .200
V2	1,189.42	16,459.83	8,272.20	4,042.82	2.00 x 0.134	1	C22 = 1.125 x 1.086 x .134

* Symmetrical Joist

STRESS ANALYSIS - PAGE 3



NEW MILLENNIUM
BUILDING SYSTEMS

Job Number: 8010-0704	Job Name: 10-123 BARRHAVEN FIRE STATION - SHOPORDERS	Date Run: 11/19/2010 4:15:50 PM
Location: OTTAWA, ON	Joist Description: Deep Long Span 58DLH515/235	Mark: J48

TCX Design

TCX Left		TCX Right	
TCX Length	0-0 1/2	TCX Length	0-0 1/2
TCX Type	R	TCX Type	R
TCX Depth	7	TCX Depth	7
BPL Length	0-6 1/2	BPL Length	0-6 1/2
Clear Bearing	0-9	Clear Bearing	0-6 7/8
BPL Material: 50 = 6 x 6 x .500		BPL Material: 50 = 6 x 6 x .500	

Total Load	515.00	Total Load	515.00
Reqd TL Def L/80	0.01	Reqd TL Def L/80	0.01
Live Load	352.50	Live Load	352.50
Reqd LL Def L/120	0.00	Reqd LL Def L/120	0.00
Section Modulus	10.2809	Section Modulus	10.2809
Reqd SM	0.0001	Reqd SM	0.0001
Mom of Inertia	44.1311	Mom of Inertia	44.1311
Reqd MI	0.0000	Reqd MI	0.0000

Seat Type: Lapped

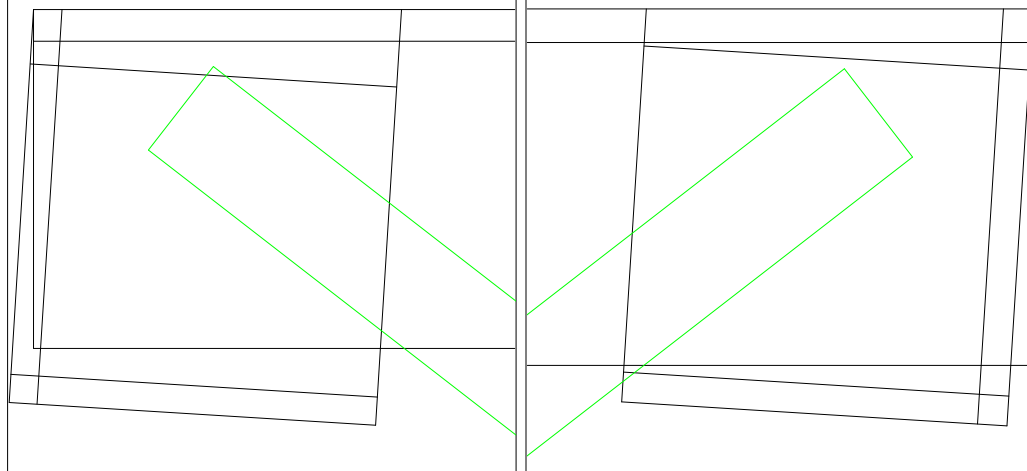

LSD Design

- | | |
|--|--|
| Case 1a: DL | Case 6a: 1.25(DL)+0.5(CL+SL)+1.4(WL+AX)+0.8(TL) |
| Case 1b: 1.4(DL) | Case 6b: 1.25(DL)+0.5(CL+SL)+1.4(WL-AX)+0.8(TL) |
| Case 2a: LL | Case 6c: 1.25(DL)+0.5(CL+SL)+1.4(WL+AX+IP)+0.8(TL) |
| Case 2b: SL | Case 6d: 1.25(DL)+0.5(CL+SL)+1.4(WL-AX+IP)+0.8(TL) |
| Case 3a: 1.25(DL+CL)+1.5(TL+LL) | Case 7a: 1.25(DL+CL)+0.4(WL+AX)+1.5(TL+LL) |
| Case 3b: 1.25(DL+CL)+1.5(TL+SL) | Case 7b: 1.25(DL+CL)+0.4(WL-AX)+1.5(TL+LL) |
| Case 3c: 1.25(DL+CL)+1.5(TL+LL+FEM) | Case 7c: 1.25(DL+CL)+0.4(WL+AX+IP)+1.5(TL+LL) |
| Case 3d: 1.25(DL+CL)+1.5(TL+SL+FEM) | Case 7d: 1.25(DL+CL)+0.4(WL-AX+IP)+1.5(TL+LL) |
| Case 3e: DL+CL+TL+LL | Case 8a: 1.25(DL+CL)+0.4(WL+AX)+1.5(TL+SL) |
| Case 3f: DL+CL+TL+SL | Case 8b: 1.25(DL+CL)+0.4(WL-AX)+1.5(TL+SL) |
| Case 4a: 1.25(DL)+0.5(CL+LL)+1.4(WL+AX)+0.8(TL) | Case 8c: 1.25(DL+CL)+0.4(WL+AX+IP)+1.5(TL+SL) |
| Case 4b: 1.25(DL)+0.5(CL+LL)+1.4(WL-AX)+0.8(TL) | Case 8d: 1.25(DL+CL)+0.4(WL-AX+IP)+1.5(TL+SL) |
| Case 4c: 1.25(DL)+0.5(CL+LL)+1.4(WL+AX+IP)+0.8(TL) | Case 9a: DL+CL+0.5(LL)+0.7(TL)+SM+AX+FEM |
| Case 4d: 1.25(DL)+0.5(CL+LL)+1.4(WL-AX+IP)+0.8(TL) | Case 9b: DL+CL+0.5(LL)+0.7(TL)+SM-AX+FEM |
| Case 4e: 1.25(DL+CL)+1.4(WL+AX)+1.1(TL)+LL | Case 9c: DL+CL+0.25(SL)+0.7(TL)+SM+AX+FEM |
| Case 4f: 1.25(DL+CL)+1.4(WL-AX)+1.1(TL)+LL | Case 9d: DL+CL+0.25(SL)+0.7(TL)+SM-AX+FEM |
| Case 5a: 0.9(DL)+1.4(WL+AX) | Case 9e: DL+CL+LL+1.1(TL)+SM+AX+FEM |
| Case 5b: 0.9(DL)+1.4(WL-AX) | Case 9f: DL+CL+LL+1.1(TL)+SM-AX+FEM |
| Case 5c: 0.9(DL)+1.4(WL+AX+IP) | Case 10a: DL+SM+AX |
| Case 5d: 0.9(DL)+1.4(WL-AX+IP) | Case 10b: DL+SM-AX |
| Case 5e: DL+SM+AX | Case 10c: DL+CL+SM+AX |
| Case 5f: DL+SM-AX | Case 10d: DL+CL+SM-AX |

STRESS ANALYSIS - PAGE 1



NEW MILLENNIUM
BUILDING SYSTEMS

Job Number: 8010-0704	Job Name: 10-123 BARRHAVEN FIRE STATION - SHOPORDERS	Date Run: 11/19/2010 3:57:06 PM
Location: OTTAWA, ON	Joist Description: Short Span Round 12K594/271	Mark: J49

Geometry

Base Length: 15-4 1/8	Working Length: 15-0 1/8	Joist Depth: 12.00	Effective Depth: 11.15	BC Panel Length: 7 @ 1-8	Shape: Parallel Chords
---------------------------------	------------------------------------	------------------------------	----------------------------------	------------------------------------	----------------------------------

Variable	Left End	Right End	Deflection Case 2a: LL (Max Deflection: -0.33 in-Y, -0.06 in-X)
BC Panel	1-10	1-10	
TC Panel	1-0	1-0	
First Half	0-10	0-10	
First Diag.	2-8	2-8	
Depth	12.00	12.00	

Loads, *** All loads are factored ***

Load Type	Category	Load1	Load2	Position	Direction	Loc/Begin	Sp/End
Uniform (plf)	DL	187.50	187.50	TC	+	0-0	15-4 1/8
Uniform (plf)	LL	406.50	406.50	TC	+	0-0	15-4 1/8
Conc Load (lbs)	DL	250.00	0.00	TC	+	<1-1 3/8>	4-10 5/8
Conc anywhere (lbs)	TL	315.00	0.00	BC	+	7-8	0-0
Net Uplift (plf)	WL	186.00	186.00	TC	-	0-0	15-4 1/8
Conc anywhere (lbs)	TL	315.00	0.00	TC	+	7-8	0-0
Conc Load (lbs)	DL	250.00	0.00	TC	+	7-10 5/8	13-10 5/8

Stress Analysis Summary

Int. Panel TC: 20.00	Max Panel BC: 20.00	Reaction LE: 5,456.77	Reaction RE: 5,379.58	Minimum Shear: 1,364.19	Max TC Comp.: 21,404.79	Max BC Tension: 22,033.21
--------------------------------	-------------------------------	---------------------------------	---------------------------------	-----------------------------------	-----------------------------------	-------------------------------------

Member	TC Tension	TC Compression	BC Tension	BC Compression	Web Tension	Web Comp.	Web Length	PP Dist.
W2	2,452.71	8,646.46	0.00	0.00	10,701.28	3,202.25	22.90	0-2
V1S	2,234.20	7,980.27	0.00	0.00	585.81	2,403.99	14.97	1-0
W3	2,234.20	7,980.27	11,637.30	3,237.13	1,798.13	5,874.18	14.97	1-10
W4	3,952.61	14,406.09	11,637.30	3,237.13	4,544.11	1,367.70	14.97	2-8
W5	3,952.61	14,406.09	17,174.87	4,668.09	1,395.92	4,445.36	14.97	3-6
W6	5,097.02	18,905.40	17,174.87	4,668.09	3,115.29	966.83	14.97	4-4
W7	5,097.02	18,905.40	20,635.93	5,525.96	995.05	3,030.65	14.97	5-2
W8	5,668.34	21,404.79	20,635.93	5,525.96	1,832.80	709.63	14.97	6-0
W9	5,668.34	21,404.79	22,033.21	5,810.72	827.85	1,832.80	14.97	6-10

* Symmetrical Joist

STRESS ANALYSIS - PAGE 2



Job Number: 8010-0704	Job Name: 10-123 BARRHAVEN FIRE STATION - SHOPORDERS	Date Run: 11/19/2010 3:57:06 PM
Location: OTTAWA, ON	Joist Description: Short Span Round 12K594/271	Mark: J49

Chord Properties

Chord	Area	Rx	Rz	Ryy	Y	Ix	Q	Material
TC	0.2991	0.4478	0.2552	0.8119	0.4273	0.0600	1.0000	A18 = 1.4375 x .115
BC	0.2991	0.4478	0.2552	0.8119	0.4273	0.0600	1.0000	A18 = 1.4375 x .115

Axial and Bending Analysis

K: 1.00	Fy: 50,000.00	Fb: 45,000.00	Mom of Inertia: 37.28	LL 360: 411.80	LL 240: 617.71	Max Bridg TC: 9-9 3/4	Max Bridg BC: 9-10 3/8
-------------------	-------------------------	-------------------------	---------------------------------	--------------------------	--------------------------	---------------------------------	----------------------------------

Top Chord Check	End Panel LE	First Panel LE	Interior Panel	First Panel RE	End Panel RE	
Length	10.00	20.00	20.00	20.13	10.00	Gap Between Chords: 0.5000
Bending Load	576.41	0.00	0.00	0.00	576.41	Min Weld Len 2X: 0.5000
Axial Load	8,646.46	7,980.27	21,404.79	7,868.41	8,545.74	Max Load Fillers TC: 22,626.30
fa	14,452.31	13,338.80	35,777.53	13,151.84	14,283.97	Max Load no Fillers TC: 16,756.02
Maximum K L/r	44.34	78.36	44.67	78.85	44.34	TC OAL/Ryy: 221.8572
Fcr	43,304.98	31,913.93	43,213.45	31,734.76	43,304.98	BC Stress: 41,740.74
Fa	38,974.48	28,722.54	38,892.11	28,561.29	38,974.48	BC L/Rz: 78.3617
F'e	573,863.25	143,465.81	143,465.81	141,689.17	573,863.25	TC Shear Stress: 23,746.62
Cm	0.9916	0.9690	0.8892	0.9691	0.9917	BC Shear Stress: 23,746.62
Panel Point Moment	1614.03	583.33	583.33	583.33	1631.03	
Mid Panel Moment	484.12	492.19	492.19	492.19	480.02	
Panel Point fb	13593.36	4912.82	4912.82	4912.82	13736.54	
Mid Panel fb	1724.36	1753.11	1753.11	1753.11	1709.76	
Fillers	0	0	4	0	0	
Panel Point Stress	28,045.67	18,251.62	40,690.35	18,064.66	28,020.52	
Mid Panel Stress	0.4056	0.5018	0.9625	0.4979	0.4009	

Web Design

Member	Web Tension	Allow Tension	Web Comp	Allow Comp	Weld	Qty	Material
W2	10,701.28	12,549.50	3,202.25	7,110.22	2.60 x 0.185	1	R3 = round 5/8
V1S	585.81	11,294.55	2,403.99	6,479.35	2.00 x 0.177	1	R2 = round 9/16
W3	1,798.13	11,294.55	5,874.18	6,479.35	2.00 x 0.177	1	R2 = round 9/16
W4	4,544.11	11,294.55	1,367.70	6,479.35	2.00 x 0.177	1	R2 = round 9/16
W5	1,395.92	11,294.55	4,445.36	6,479.35	2.00 x 0.177	1	R2 = round 9/16
W6	3,115.29	8,924.09	966.83	4,416.93	2.00 x 0.170	1	R1 = round 1/2
W7	995.05	8,924.09	3,030.65	4,416.93	2.00 x 0.170	1	R1 = round 1/2
W8	1,832.80	8,924.09	709.63	4,416.93	2.00 x 0.170	1	R1 = round 1/2
W9	827.85	8,924.09	1,832.80	4,416.93	2.00 x 0.170	1	R1 = round 1/2

* Symmetrical Joist

STRESS ANALYSIS - PAGE 3



NEW MILLENNIUM
BUILDING SYSTEMS

Job Number: 8010-0704	Job Name: 10-123 BARRHAVEN FIRE STATION - SHOPORDERS	Date Run: 11/19/2010 3:57:06 PM
Location: OTTAWA, ON	Joist Description: Short Span Round 12K594/271	Mark: J49

TCX Design

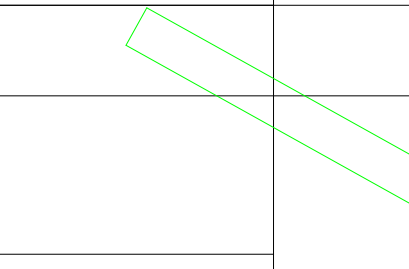
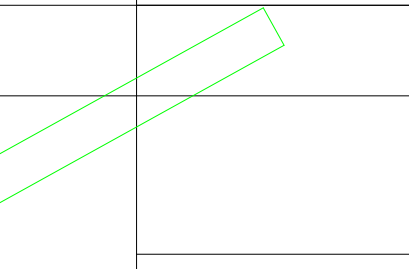
TCX Left		TCX Right	
TCX Length	0-1 3/8	TCX Length	0-1 3/8
TCX Type	R	TCX Type	R
TCX Depth	4	TCX Depth	4
BPL Length	0-4	BPL Length	0-4
Clear Bearing	0-7 3/4	Clear Bearing	0-7 3/4
BPL Material: 69L = 2 x 3 x .250		BPL Material: 69L = 2 x 3 x .250	
Total Load	594.00	Total Load	594.00
Reqd TL Def L/80	0.02	Reqd TL Def L/80	0.02
Live Load	406.50	Live Load	406.50
Reqd LL Def L/120	0.01	Reqd LL Def L/120	0.01
Section Modulus	0.1187	Section Modulus	0.1187
Reqd SM	0.0011	Reqd SM	0.0011
Mom of Inertia	0.1200	Mom of Inertia	0.1200
Reqd MI	0.0000	Reqd MI	0.0000
Seat Type: Bird Cage		Seat Type: Bird Cage	
			

LSD Design

- | | |
|--|--|
| Case 1a: DL | Case 6a: 1.25(DL)+0.5(CL+SL)+1.4(WL+AX)+0.8(TL) |
| Case 1b: 1.4(DL) | Case 6b: 1.25(DL)+0.5(CL+SL)+1.4(WL-AX)+0.8(TL) |
| Case 2a: LL | Case 6c: 1.25(DL)+0.5(CL+SL)+1.4(WL+AX+IP)+0.8(TL) |
| Case 2b: SL | Case 6d: 1.25(DL)+0.5(CL+SL)+1.4(WL-AX+IP)+0.8(TL) |
| Case 3a: 1.25(DL+CL)+1.5(TL+LL) | Case 7a: 1.25(DL+CL)+0.4(WL+AX)+1.5(TL+LL) |
| Case 3b: 1.25(DL+CL)+1.5(TL+SL) | Case 7b: 1.25(DL+CL)+0.4(WL-AX)+1.5(TL+LL) |
| Case 3c: 1.25(DL+CL)+1.5(TL+LL+FEM) | Case 7c: 1.25(DL+CL)+0.4(WL+AX+IP)+1.5(TL+LL) |
| Case 3d: 1.25(DL+CL)+1.5(TL+SL+FEM) | Case 7d: 1.25(DL+CL)+0.4(WL-AX+IP)+1.5(TL+LL) |
| Case 3e: DL+CL+TL+LL | Case 8a: 1.25(DL+CL)+0.4(WL+AX)+1.5(TL+SL) |
| Case 3f: DL+CL+TL+SL | Case 8b: 1.25(DL+CL)+0.4(WL-AX)+1.5(TL+SL) |
| Case 4a: 1.25(DL)+0.5(CL+LL)+1.4(WL+AX)+0.8(TL) | Case 8c: 1.25(DL+CL)+0.4(WL+AX+IP)+1.5(TL+SL) |
| Case 4b: 1.25(DL)+0.5(CL+LL)+1.4(WL-AX)+0.8(TL) | Case 8d: 1.25(DL+CL)+0.4(WL-AX+IP)+1.5(TL+SL) |
| Case 4c: 1.25(DL)+0.5(CL+LL)+1.4(WL+AX+IP)+0.8(TL) | Case 9a: DL+CL+0.5(LL)+0.7(TL)+SM+AX+FEM |
| Case 4d: 1.25(DL)+0.5(CL+LL)+1.4(WL-AX+IP)+0.8(TL) | Case 9b: DL+CL+0.5(LL)+0.7(TL)+SM-AX+FEM |
| Case 4e: 1.25(DL+CL)+1.4(WL+AX)+1.1(TL)+LL | Case 9c: DL+CL+0.25(SL)+0.7(TL)+SM+AX+FEM |
| Case 4f: 1.25(DL+CL)+1.4(WL-AX)+1.1(TL)+LL | Case 9d: DL+CL+0.25(SL)+0.7(TL)+SM-AX+FEM |
| Case 5a: 0.9(DL)+1.4(WL+AX) | Case 9e: DL+CL+LL+1.1(TL)+SM+AX+FEM |
| Case 5b: 0.9(DL)+1.4(WL-AX) | Case 9f: DL+CL+LL+1.1(TL)+SM-AX+FEM |
| Case 5c: 0.9(DL)+1.4(WL+AX+IP) | Case 10a: DL+SM+AX |
| Case 5d: 0.9(DL)+1.4(WL-AX+IP) | Case 10b: DL+SM-AX |
| Case 5e: DL+SM+AX | Case 10c: DL+CL+SM+AX |
| Case 5f: DL+SM-AX | Case 10d: DL+CL+SM-AX |

STRESS ANALYSIS - PAGE 1



NEW MILLENNIUM
BUILDING SYSTEMS

Job Number: 8010-0704	Job Name: 10-123 BARRHAVEN FIRE STATION - SHOPORDERS	Date Run: 11/19/2010 3:57:06 PM
Location: OTTAWA, ON	Joist Description: Short Span Round 12K594/271	Mark: J51

Geometry

Base Length: 19-9 3/8	Working Length: 19-5 3/8	Joist Depth: 12.00	Effective Depth: 11.14	BC Panel Length: 9 @ 1-8	Shape: Parallel Chords
---------------------------------	------------------------------------	------------------------------	----------------------------------	------------------------------------	----------------------------------

Variable	Left End	Right End	Deflection Case 2a: LL (Max Deflection: -0.62 in-Y, -0.09 in-X)
BC Panel	2-4 3/4	2-4 3/4	
TC Panel	1-6 3/4	1-6 3/4	
First Half	0-10	0-10	
First Diag.	3-2 3/4	3-2 3/4	
Depth	12.00	12.00	

Loads, *** All loads are factored ***

Load Type	Category	Load1	Load2	Position	Direction	Loc/Begin	Sp/End
Uniform (plf)	DL	187.50	187.50	TC	+	0-0	19-9 3/8
Uniform (plf)	LL	406.50	406.50	TC	+	0-0	19-9 3/8
Conc anywhere (lbs)	TL	315.00	0.00	BC	+	9-10 3/4	0-0
Conc anywhere (lbs)	TL	315.00	0.00	TC	+	9-10 3/4	0-0
Net Uplift (plf)	WL	186.00	186.00	TC	-	0-0	19-9 3/8

Stress Analysis Summary

Int. Panel TC: 20.00	Max Panel BC: 20.00	Reaction LE: 6,389.88	Reaction RE: 6,397.95	Minimum Shear: 1,599.49	Max TC Comp.: 32,839.18	Max BC Tension: 33,420.58
--------------------------------	-------------------------------	---------------------------------	---------------------------------	-----------------------------------	-----------------------------------	-------------------------------------

Member	TC Tension	TC Compression	BC Tension	BC Compression	Web Tension	Web Comp.	Web Length	PP Dist.
W2	4,154.79	13,635.72	0.00	0.00	15,547.67	4,500.43	28.98	0-2
V1S	3,891.30	12,818.94	0.00	0.00	394.37	2,157.42	14.97	1-6 3/4
W3	3,891.30	12,818.94	17,099.62	5,181.00	1,931.62	6,693.24	14.97	2-4 3/4
W4	6,183.89	20,491.28	17,099.62	5,181.00	5,366.82	1,503.71	14.97	3-2 3/4
W5	6,183.89	20,491.28	23,882.94	7,186.79	1,503.71	5,301.68	14.97	4-0 3/4
W6	7,902.89	26,385.58	23,882.94	7,186.79	3,971.10	1,074.46	14.97	4-10 3/4
W7	7,902.89	26,385.58	28,888.22	8,618.99	1,074.46	3,895.11	14.97	5-8 3/4
W8	9,048.30	30,501.84	28,888.22	8,618.99	2,564.53	645.21	14.97	6-6 3/4
W9	9,048.30	30,501.84	32,115.46	9,477.60	645.21	2,499.39	14.97	7-4 3/4
W10	9,620.10	32,839.18	32,115.46	9,477.60	2,149.75	626.10	14.97	8-2 3/4
W11	9,620.10	32,839.18	33,420.58	9,762.60	626.10	2,149.75	14.97	9-0 3/4

* Symmetrical Joist

STRESS ANALYSIS - PAGE 2



NEW MILLENNIUM
BUILDING SYSTEMS

Job Number: 8010-0704	Job Name: 10-123 BARRHAVEN FIRE STATION - SHOPORDERS	Date Run: 11/19/2010 3:57:06 PM
Location: OTTAWA, ON		Joist Description: Short Span Round 12K594/271
		Mark: J51

Chord Properties

Chord	Area	Rx	Rz	Ryy	Y	Ix	Q	Material
TC	0.4410	0.4610	0.2946	0.8233	0.4321	0.0937	1.0000	12 = 1 1/2 x 1 1/2 x .155
BC	0.4410	0.4610	0.2946	0.8233	0.4321	0.0937	1.0000	12 = 1 1/2 x 1 1/2 x .155

Axial and Bending Analysis

K: 1.00	Fy: 50,000.00	Fb: 45,000.00	Mom of Inertia: 54.87	LL 360: 278.69	LL 240: 418.04	Max Bridg TC: 9-11 3/8	Max Bridg BC: 9-6 3/8
-------------------	-------------------------	-------------------------	---------------------------------	--------------------------	--------------------------	----------------------------------	---------------------------------

Top Chord Check	End Panel LE	First Panel LE	Interior Panel	First Panel RE	End Panel RE	
Length	16.75	20.00	20.00	19.88	16.75	Gap Between Chords: 0.5000
Bending Load	576.41	0.00	0.00	0.00	576.41	Min Weld Len 2X: 0.5000
Axial Load	13,635.72	12,818.94	32,839.18	12,768.17	13,572.01	Max Load Fillers TC: 34,146.45
fa	15,460.88	14,534.77	37,234.74	14,477.21	15,388.63	Max Load no Fillers TC: 28,071.26
Maximum K L/r	56.85	67.88	43.73	67.46	56.85	TC OAL/Ryy: 283.4779
Fcr	39,477.18	35,699.19	43,475.94	35,849.37	39,477.18	BC Stress: 41,217.42
Fa	35,529.46	32,129.27	39,128.35	32,264.43	35,529.46	BC L/Rz: 67.8793
F'e	216,817.16	152,076.91	152,076.91	153,995.84	216,817.16	TC Shear Stress: 15,210.21
Cm	0.9762	0.9681	0.8912	0.9687	0.9763	BC Shear Stress: 15,210.21
Panel Point Moment	2277.26	583.33	583.33	583.33	2264.09	
Mid Panel Moment	1536.98	492.19	492.19	492.19	1541.97	
Panel Point fb	12974.37	3323.46	3323.46	3323.46	12899.32	
Mid Panel fb	3542.84	1134.53	1134.53	1134.53	3554.34	
Fillers	0	0	4	0	0	
Panel Point Stress	28,435.25	17,858.22	40,558.20	17,800.67	28,287.96	
Mid Panel Stress	0.5094	0.4767	0.9790	0.4729	0.5075	

Web Design

Member	Web Tension	Allow Tension	Web Comp	Allow Comp	Weld	Qty	Material
W2	15,547.67	18,071.28	4,500.43	9,676.85	3.49 x 0.200	1	R5 = round 3/4
V1S	394.37	13,943.89	2,157.42	8,996.48	2.00 x 0.185	1	R3 = round 5/8
W3	1,931.62	13,943.89	6,693.24	8,996.48	2.00 x 0.185	1	R3 = round 5/8
W4	5,366.82	13,943.89	1,503.71	8,996.48	2.00 x 0.185	1	R3 = round 5/8
W5	1,503.71	13,943.89	5,301.68	8,996.48	2.00 x 0.185	1	R3 = round 5/8
W6	3,971.10	8,924.09	1,074.46	4,499.90	2.00 x 0.170	1	R1 = round 1/2
W7	1,074.46	8,924.09	3,895.11	4,499.90	2.00 x 0.170	1	R1 = round 1/2
W8	2,564.53	8,924.09	645.21	4,499.90	2.00 x 0.170	1	R1 = round 1/2
W9	645.21	8,924.09	2,499.39	4,499.90	2.00 x 0.170	1	R1 = round 1/2
W10	2,149.75	8,924.09	626.10	4,499.90	2.00 x 0.170	1	R1 = round 1/2
W11	626.10	8,924.09	2,149.75	4,499.90	2.00 x 0.170	1	R1 = round 1/2

* Symmetrical Joist

STRESS ANALYSIS - PAGE 3



NEW MILLENNIUM
BUILDING SYSTEMS

Job Number: 8010-0704	Job Name: 10-123 BARRHAVEN FIRE STATION - SHOPORDERS	Date Run: 11/19/2010 3:57:06 PM
Location: OTTAWA, ON	Joist Description: Short Span Round 12K594/271	Mark: J51

TCX Design

TCX Left		TCX Right	
TCX Length	0-1 3/8	TCX Length	0-0 1/2
TCX Type	R	TCX Type	R
TCX Depth	4	TCX Depth	4
BPL Length	0-5 3/8	BPL Length	0-4 1/2
Clear Bearing	0-11	Clear Bearing	0-10
BPL Material: 69L = 2 x 3 x .250		BPL Material: 69L = 2 x 3 x .250	
Total Load	594.00	Total Load	594.00
Reqd TL Def L/80	0.02	Reqd TL Def L/80	0.01
Live Load	406.50	Live Load	406.50
Reqd LL Def L/120	0.01	Reqd LL Def L/120	0.00
Section Modulus	0.1755	Section Modulus	0.1755
Reqd SM	0.0011	Reqd SM	0.0001
Mom of Inertia	0.1874	Mom of Inertia	0.1874
Reqd MI	0.0000	Reqd MI	0.0000
Seat Type: Lapped		Seat Type: Lapped	

LSD Design

- | | |
|--|--|
| Case 1a: DL | Case 6a: 1.25(DL)+0.5(CL+SL)+1.4(WL+AX)+0.8(TL) |
| Case 1b: 1.4(DL) | Case 6b: 1.25(DL)+0.5(CL+SL)+1.4(WL-AX)+0.8(TL) |
| Case 2a: LL | Case 6c: 1.25(DL)+0.5(CL+SL)+1.4(WL+AX+IP)+0.8(TL) |
| Case 2b: SL | Case 6d: 1.25(DL)+0.5(CL+SL)+1.4(WL-AX+IP)+0.8(TL) |
| Case 3a: 1.25(DL+CL)+1.5(TL+LL) | Case 7a: 1.25(DL+CL)+0.4(WL+AX)+1.5(TL+LL) |
| Case 3b: 1.25(DL+CL)+1.5(TL+SL) | Case 7b: 1.25(DL+CL)+0.4(WL-AX)+1.5(TL+LL) |
| Case 3c: 1.25(DL+CL)+1.5(TL+LL+FEM) | Case 7c: 1.25(DL+CL)+0.4(WL+AX+IP)+1.5(TL+LL) |
| Case 3d: 1.25(DL+CL)+1.5(TL+SL+FEM) | Case 7d: 1.25(DL+CL)+0.4(WL-AX+IP)+1.5(TL+LL) |
| Case 3e: DL+CL+TL+LL | Case 8a: 1.25(DL+CL)+0.4(WL+AX)+1.5(TL+SL) |
| Case 3f: DL+CL+TL+SL | Case 8b: 1.25(DL+CL)+0.4(WL-AX)+1.5(TL+SL) |
| Case 4a: 1.25(DL)+0.5(CL+LL)+1.4(WL+AX)+0.8(TL) | Case 8c: 1.25(DL+CL)+0.4(WL+AX+IP)+1.5(TL+SL) |
| Case 4b: 1.25(DL)+0.5(CL+LL)+1.4(WL-AX)+0.8(TL) | Case 8d: 1.25(DL+CL)+0.4(WL-AX+IP)+1.5(TL+SL) |
| Case 4c: 1.25(DL)+0.5(CL+LL)+1.4(WL+AX+IP)+0.8(TL) | Case 9a: DL+CL+0.5(LL)+0.7(TL)+SM+AX+FEM |
| Case 4d: 1.25(DL)+0.5(CL+LL)+1.4(WL-AX+IP)+0.8(TL) | Case 9b: DL+CL+0.5(LL)+0.7(TL)+SM-AX+FEM |
| Case 4e: 1.25(DL+CL)+1.4(WL+AX)+1.1(TL)+LL | Case 9c: DL+CL+0.25(SL)+0.7(TL)+SM+AX+FEM |
| Case 4f: 1.25(DL+CL)+1.4(WL-AX)+1.1(TL)+LL | Case 9d: DL+CL+0.25(SL)+0.7(TL)+SM-AX+FEM |
| Case 5a: 0.9(DL)+1.4(WL+AX) | Case 9e: DL+CL+LL+1.1(TL)+SM+AX+FEM |
| Case 5b: 0.9(DL)+1.4(WL-AX) | Case 9f: DL+CL+LL+1.1(TL)+SM-AX+FEM |
| Case 5c: 0.9(DL)+1.4(WL+AX+IP) | Case 10a: DL+SM+AX |
| Case 5d: 0.9(DL)+1.4(WL-AX+IP) | Case 10b: DL+SM-AX |
| Case 5e: DL+SM+AX | Case 10c: DL+CL+SM+AX |
| Case 5f: DL+SM-AX | Case 10d: DL+CL+SM-AX |

STRESS ANALYSIS - PAGE 1



NEW MILLENNIUM
BUILDING SYSTEMS

Job Number: 8010-0704	Job Name: 10-123 BARRHAVEN FIRE STATION - SHOPORDERS	Date Run: 11/19/2010 3:57:06 PM
Location: OTTAWA, ON	Joist Description: Short Span Crimp 20K626/289	Mark: TJ03

Geometry

Base Length: 22-8 5/8	Working Length: 22-4 5/8	Joist Depth: 20.00	Effective Depth: 19.15	BC Panel Length: 5 @ 4-0	Shape: Parallel Chords
---------------------------------	------------------------------------	------------------------------	----------------------------------	------------------------------------	----------------------------------

Variable	Left End	Right End	Deflection Case 2a: LL (Max Deflection: -0.50 in-Y, -0.09 in-X)
BC Panel	1-9 1/2	1-9 1/2	
TC Panel	1-8 1/8	1-8 1/8	
First Half	1-6 3/4	1-6 7/8	
First Diag.	3-4 1/4	3-4 3/8	
Depth	20.00	20.00	

Loads, *** All loads are factored ***

Load Type	Category	Load1	Load2	Position	Direction	Loc/Begin	Sp/End
Uniform (plf)	DL	192.50	192.50	TC	+	0-0	22-8 5/8
Uniform (plf)	LL	433.50	433.50	TC	+	0-0	22-8 5/8
Uniform (plf)	TL	234.00	0.00	TC	+	<0-0 1/4>	6-9 3/4
Conc anywhere (lbs)	TL	315.00	0.00	BC	+	11-4 1/4	0-0
Net Uplift (plf)	WL	197.00	197.00	TC	-	0-0	22-8 5/8
Conc anywhere (lbs)	TL	315.00	0.00	TC	+	11-4 1/4	0-0

Stress Analysis Summary

Int. Panel TC: 24.00	Max Panel BC: 48.00	Reaction LE: 8,374.88	Reaction RE: 7,718.10	Minimum Shear: 2,093.72	Max TC Comp.: 26,329.89	Max BC Tension 27,206.54
--------------------------------	-------------------------------	---------------------------------	---------------------------------	-----------------------------------	-----------------------------------	------------------------------------

Member	TC Tension	TC Compression	BC Tension	BC Compression	Web Tension	Web Comp.	Web Length	PP Dist.
W2	2,155.27	7,570.15	0.00	0.00	11,039.23	3,020.70	27.33	0-2
V1S	2,132.07	7,477.51	0.00	0.00	325.06	1,999.91	19.20	1-8 1/8
W3	2,132.07	7,477.51	13,493.28	3,898.59	2,516.54	8,900.72	26.80	1-9 1/2
W4	5,676.28	19,456.94	13,493.28	3,898.59	8,025.37	2,277.58	30.70	3-4 1/4
W5	5,676.28	19,456.94	23,688.20	6,945.69	1,627.33	5,836.33	30.70	5-4 1/4
W6	7,706.80	26,329.89	23,688.20	6,945.69	3,828.89	977.07	30.70	7-4 1/4
W7	7,706.80	26,329.89	27,206.54	7,959.62	909.76	3,357.04	30.70	9-4 1/4

* Symmetrical Joist

Standard Verticals

Member	Position	Max Tension	Max Comp.	Length
V2	Interior	440.07	2,143.88	19.15

STRESS ANALYSIS - PAGE 2



Job Number: 8010-0704	Job Name: 10-123 BARRHAVEN FIRE STATION - SHOPORDERS	Date Run: 11/19/2010 3:57:06 PM
Location: OTTAWA, ON	Joist Description: Short Span Crimp 20K626/289	Mark: TJ03

Chord Properties

Chord	Area	Rx	Rz	Ryy	Y	Ix	Q	Material
TC	0.3922	0.4635	0.2955	1.0914	0.4256	0.0843	0.9945	10 = 1 1/2 x 1 1/2 x .137
BC	0.3922	0.4635	0.2955	1.0914	0.4256	0.0843	0.9945	10 = 1 1/2 x 1 1/2 x .137

Axial and Bending Analysis

K: 1.00	Fy: 50,000.00	Fb: 45,000.00	Mom of Inertia: 143.99	LL 360: 479.56	LL 240: 719.34	Max Bridg TC: 13-2 1/4	Max Bridg BC: 11-11 3/4
-------------------	-------------------------	-------------------------	----------------------------------	--------------------------	--------------------------	----------------------------------	-----------------------------------

Top Chord Check	End Panel LE	First Panel LE	Interior Panel	First Panel RE	End Panel RE	
Length	18.13	20.13	24.00	20.25	18.13	Gap Between Chords: 1.1250
Bending Load	816.34	0.00	0.00	0.00	606.93	Min Weld Len 2X: 0.5000
Axial Load	7,570.15	7,477.51	26,329.89	6,992.74	7,064.62	Max Load Fillers TC: 28,203.87
fa	9,650.11	9,532.02	33,564.26	8,914.06	9,005.69	Max Load no Fillers TC: 21,290.23
Maximum K L/r	61.33	68.10	51.78	68.52	61.33	TC OAL/Ryy: 246.1366
Fcr	37,825.30	35,491.27	40,916.21	35,342.46	37,825.30	BC Stress: 43,607.73
Fa	34,042.77	31,942.14	36,824.59	31,808.21	34,042.77	BC L/Rz: 162.4212
F'e	187,166.20	151,813.95	106,748.30	149,945.48	187,166.20	TC Shear Stress: 19,477.30
Cm	0.9828	0.9791	0.8603	0.9802	0.9840	BC Shear Stress: 19,477.30
Panel Point Moment	3097.04	700.00	700.00	700.00	2491.71	
Mid Panel Moment	2339.08	590.63	590.63	590.63	1893.19	
Panel Point fb	19745.72	4462.97	4462.97	4462.97	15886.36	
Mid Panel fb	5906.69	1491.46	1491.46	1491.46	4780.71	
Fillers	0	0	4	0	0	
Panel Point Stress	29,395.83	13,995.00	38,027.24	13,377.04	24,892.04	
Mid Panel Stress	0.4058	0.3296	0.9506	0.3113	0.3633	

Web Design

Member	Web Tension	Allow Tension	Web Comp	Allow Comp	Weld	Qty	Material
W2	11,039.23	12,234.36	3,020.70	8,092.45	4.31 x 0.115	1	C18 = 1.125 x 1.012 x .115
W3	2,516.54	16,459.83	8,900.72	9,059.74	2.98 x 0.134	1	C22 = 1.125 x 1.086 x .134
W4	8,025.37	8,461.40	2,277.58	2,586.29	4.00 x 0.090	1	C12 = 1.125 x 0.715 x .090
W5	1,627.33	11,869.06	5,836.33	5,921.31	2.50 x 0.105	1	C16 = 1.125 x 0.943 x .105
W6	3,828.89	7,215.59	977.07	2,150.88	2.24 x 0.077	1	C10 = 1.125 x 0.700 x 0.07
W7	909.76	11,869.06	3,357.04	5,921.31	2.00 x 0.105	1	C16 = 1.125 x 0.943 x .105
V1	325.06	7,215.59	1,999.91	4,324.84	2.00 x 0.077	1	C10 = 1.125 x 0.700 x 0.07
V2	440.07	7,215.59	2,143.88	4,334.94	2.00 x 0.077	1	C10 = 1.125 x 0.700 x 0.07

* Symmetrical Joist

STRESS ANALYSIS - PAGE 3



NEW MILLENNIUM
BUILDING SYSTEMS

Job Number: 8010-0704	Job Name: 10-123 BARRHAVEN FIRE STATION - SHOPORDERS	Date Run: 11/19/2010 3:57:06 PM
Location: OTTAWA, ON	Joist Description: Short Span Crimp 20K626/289	Mark: TJ03

TCX Design

TCX Left		TCX Right	
TCX Length	0-0 1/4	TCX Length	0-0
TCX Type	R	TCX Type	R
TCX Depth	4	TCX Depth	4
BPL Length	0-4 1/4	BPL Length	0-10 1/8
Clear Bearing	0-4 3/8	Clear Bearing	0-5 1/4
BPL Material: 69L = 2 x 3 x .250		BPL Material: 27 = 2 1/2 x 2 1/2 x .250	
Total Load	626.00	Total Load	626.00
Reqd TL Def L/80	0.00	Reqd TL Def L/80	0.00
Live Load	433.50	Live Load	433.50
Reqd LL Def L/120	0.00	Reqd LL Def L/120	0.00
Section Modulus	0.1568	Section Modulus	0.0000
Reqd SM	0.0000	Reqd SM	0.0000
Mom of Inertia	0.1685	Mom of Inertia	0.0000
Reqd MI	0.0000	Reqd MI	0.0000
Seat Type: Lapped		Seat Type: Pegged or Butted	

LSD Design

- | | |
|--|--|
| Case 1a: DL | Case 6a: 1.25(DL)+0.5(CL+SL)+1.4(WL+AX)+0.8(TL) |
| Case 1b: 1.4(DL) | Case 6b: 1.25(DL)+0.5(CL+SL)+1.4(WL-AX)+0.8(TL) |
| Case 2a: LL | Case 6c: 1.25(DL)+0.5(CL+SL)+1.4(WL+AX+IP)+0.8(TL) |
| Case 2b: SL | Case 6d: 1.25(DL)+0.5(CL+SL)+1.4(WL-AX+IP)+0.8(TL) |
| Case 3a: 1.25(DL+CL)+1.5(TL+LL) | Case 7a: 1.25(DL+CL)+0.4(WL+AX)+1.5(TL+LL) |
| Case 3b: 1.25(DL+CL)+1.5(TL+SL) | Case 7b: 1.25(DL+CL)+0.4(WL-AX)+1.5(TL+LL) |
| Case 3c: 1.25(DL+CL)+1.5(TL+LL+FEM) | Case 7c: 1.25(DL+CL)+0.4(WL+AX+IP)+1.5(TL+LL) |
| Case 3d: 1.25(DL+CL)+1.5(TL+SL+FEM) | Case 7d: 1.25(DL+CL)+0.4(WL-AX+IP)+1.5(TL+LL) |
| Case 3e: DL+CL+TL+LL | Case 8a: 1.25(DL+CL)+0.4(WL+AX)+1.5(TL+SL) |
| Case 3f: DL+CL+TL+SL | Case 8b: 1.25(DL+CL)+0.4(WL-AX)+1.5(TL+SL) |
| Case 4a: 1.25(DL)+0.5(CL+LL)+1.4(WL+AX)+0.8(TL) | Case 8c: 1.25(DL+CL)+0.4(WL+AX+IP)+1.5(TL+SL) |
| Case 4b: 1.25(DL)+0.5(CL+LL)+1.4(WL-AX)+0.8(TL) | Case 8d: 1.25(DL+CL)+0.4(WL-AX+IP)+1.5(TL+SL) |
| Case 4c: 1.25(DL)+0.5(CL+LL)+1.4(WL+AX+IP)+0.8(TL) | Case 9a: DL+CL+0.5(LL)+0.7(TL)+SM+AX+FEM |
| Case 4d: 1.25(DL)+0.5(CL+LL)+1.4(WL-AX+IP)+0.8(TL) | Case 9b: DL+CL+0.5(LL)+0.7(TL)+SM-AX+FEM |
| Case 4e: 1.25(DL+CL)+1.4(WL+AX)+1.1(TL)+LL | Case 9c: DL+CL+0.25(SL)+0.7(TL)+SM+AX+FEM |
| Case 4f: 1.25(DL+CL)+1.4(WL-AX)+1.1(TL)+LL | Case 9d: DL+CL+0.25(SL)+0.7(TL)+SM-AX+FEM |
| Case 5a: 0.9(DL)+1.4(WL+AX) | Case 9e: DL+CL+LL+1.1(TL)+SM+AX+FEM |
| Case 5b: 0.9(DL)+1.4(WL-AX) | Case 9f: DL+CL+LL+1.1(TL)+SM-AX+FEM |
| Case 5c: 0.9(DL)+1.4(WL+AX+IP) | Case 10a: DL+SM+AX |
| Case 5d: 0.9(DL)+1.4(WL-AX+IP) | Case 10b: DL+SM-AX |
| Case 5e: DL+SM+AX | Case 10c: DL+CL+SM+AX |
| Case 5f: DL+SM-AX | Case 10d: DL+CL+SM-AX |

STRESS ANALYSIS - PAGE 1



NEW MILLENNIUM
BUILDING SYSTEMS

Job Number: 8010-0704	Job Name: 10-123 BARRHAVEN FIRE STATION - SHOPORDERS	Date Run: 11/19/2010 3:57:07 PM
Location: OTTAWA, ON	Joist Description: Short Span Crimp 20K616/281	Mark: TJ05

Geometry

Base Length: 23-2	Working Length: 22-10	Joist Depth: 20.00	Effective Depth: 19.15	BC Panel Length: 5 @ 4-0	Shape: Parallel Chords
-----------------------------	---------------------------------	------------------------------	----------------------------------	------------------------------------	----------------------------------

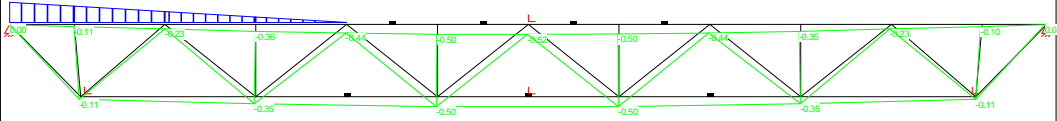
Variable	Left End	Right End	Deflection Case 2a: LL (Max Deflection: -0.52 in-Y, -0.10 in-X) 
BC Panel	1-8 3/4	1-8 3/4	
TC Panel	1-7	1-7	
First Half	1-10 1/4	1-10 1/4	
First Diag.	3-7	3-7	
Depth	20.00	20.00	

Loads, *** All loads are factored ***

Load Type	Category	Load1	Load2	Position	Direction	Loc/Begin	Sp/End
Uniform (plf)	DL	193.50	193.50	TC	+	0-0	23-2
Uniform (plf)	LL	421.50	421.50	TC	+	0-0	23-2
Conc anywhere (lbs)	TL	315.00	0.00	BC	+	11-7	0-0
Uniform (plf)	TL	234.00	0.00	TC	+	0-0	6-10
Net Uplift (plf)	WL	197.00	197.00	TC	-	0-0	23-2
Conc anywhere (lbs)	TL	315.00	0.00	TC	+	11-7	0-0

Stress Analysis Summary

Int. Panel TC: 24.00	Max Panel BC: 48.00	Reaction LE: 8,412.75	Reaction RE: 7,736.74	Minimum Shear: 2,103.19	Max TC Comp.: 26,981.64	Max BC Tension 27,834.02
--------------------------------	-------------------------------	---------------------------------	---------------------------------	-----------------------------------	-----------------------------------	------------------------------------

Member	TC Tension	TC Compression	BC Tension	BC Compression	Web Tension	Web Comp.	Web Length	PP Dist.
W2	2,126.47	7,361.52	0.00	0.00	10,943.57	3,039.43	26.80	0-2
V1S	2,094.80	7,236.67	0.00	0.00	347.90	2,090.72	19.23	1-7
W3	2,094.80	7,236.67	14,384.94	4,215.64	2,798.12	9,754.75	29.36	1-8 3/4
W4	5,994.92	20,237.48	14,384.94	4,215.64	7,905.48	2,276.23	30.70	3-7
W5	5,994.92	20,237.48	24,390.25	7,265.84	1,625.88	5,755.71	30.70	5-7
W6	8,028.39	26,981.64	24,390.25	7,265.84	3,783.54	975.53	30.70	7-7
W7	8,028.39	26,981.64	27,834.02	8,282.57	928.10	3,372.22	30.70	9-7

* Symmetrical Joist

Standard Verticals

Member	Position	Max Tension	Max Comp.	Length
V2	Interior	438.50	2,121.11	19.15

STRESS ANALYSIS - PAGE 2



NEW MILLENNIUM
BUILDING SYSTEMS

Job Number: 8010-0704	Job Name: 10-123 BARRHAVEN FIRE STATION - SHOPORDERS	Date Run: 11/19/2010 3:57:07 PM
Location: OTTAWA, ON	Joist Description: Short Span Crimp 20K616/281	Mark: TJ05

Chord Properties

Chord	Area	Rx	Rz	Ryy	Y	Ix	Q	Material
TC	0.3922	0.4635	0.2955	1.0914	0.4256	0.0843	0.9945	10 = 1 1/2 x 1 1/2 x .137
BC	0.3922	0.4635	0.2955	1.0914	0.4256	0.0843	0.9945	10 = 1 1/2 x 1 1/2 x .137

Axial and Bending Analysis

K: 1.00	Fy: 50,000.00	Fb: 45,000.00	Mom of Inertia: 143.99	LL 360: 451.89	LL 240: 677.83	Max Bridg TC: 13-2 1/4	Max Bridg BC: 11-8 5/8
-------------------	-------------------------	-------------------------	----------------------------------	--------------------------	--------------------------	----------------------------------	----------------------------------

Top Chord Check	End Panel LE	First Panel LE	Interior Panel	First Panel RE	End Panel RE	
Length	17.00	24.00	24.00	24.00	17.00	Gap Between Chords: 1.1250
Bending Load	808.37	0.00	0.00	0.00	596.72	Min Weld Len 2X: 0.5000
Axial Load	7,361.52	7,236.67	26,981.64	6,751.35	6,847.36	Max Load Fillers TC: 28,203.87
fa	9,384.17	9,225.01	34,395.09	8,606.34	8,728.74	Max Load no Fillers TC: 21,290.23
Maximum K L/r	57.52	81.21	51.78	81.21	57.52	TC OAL/Ryy: 251.0616
Fcr	39,090.43	30,782.02	40,916.21	30,782.02	39,090.43	BC Stress: 44,407.62
Fa	35,181.39	27,703.82	36,824.59	27,703.82	35,181.39	BC L/Rz: 162.4212
F'e	212,757.86	106,748.30	106,748.30	106,748.30	212,757.86	TC Shear Stress: 19,640.94
Cm	0.9853	0.9712	0.8568	0.9731	0.9863	BC Shear Stress: 19,640.94
Panel Point Moment	3518.45	700.00	700.00	700.00	2765.87	
Mid Panel Moment	1790.73	590.63	590.63	590.63	1474.30	
Panel Point fb	22432.52	4462.97	4462.97	4462.97	17634.31	
Mid Panel fb	4521.98	1491.46	1491.46	1491.46	3722.94	
Fillers	0	0	4	0	0	
Panel Point Stress	31,816.69	13,687.99	38,858.06	13,069.31	26,363.05	
Mid Panel Stress	0.3598	0.3648	0.9736	0.3423	0.3245	

Web Design

Member	Web Tension	Allow Tension	Web Comp	Allow Comp	Weld	Qty	Material
W2	10,943.57	12,234.36	3,039.43	8,176.97	4.27 x 0.115	1	C18 = 1.125 x 1.012 x .115
W3	2,798.12	21,718.85	9,754.75	11,681.61	2.92 x 0.150	1	C28 = 1.125 x 1.347 x .150
W4	7,905.48	8,461.40	2,276.23	2,586.29	3.94 x 0.090	1	C12 = 1.125 x 0.715 x .090
W5	1,625.88	11,869.06	5,755.71	5,921.31	2.46 x 0.105	1	C16 = 1.125 x 0.943 x .105
W6	3,783.54	7,215.59	975.53	2,150.88	2.21 x 0.077	1	C10 = 1.125 x 0.700 x 0.07
W7	928.10	11,869.06	3,372.22	5,921.31	2.00 x 0.105	1	C16 = 1.125 x 0.943 x .105
V1	347.90	7,215.59	2,090.72	4,318.59	2.00 x 0.077	1	C10 = 1.125 x 0.700 x 0.07
V2	438.50	7,215.59	2,121.11	4,334.94	2.00 x 0.077	1	C10 = 1.125 x 0.700 x 0.07

* Symmetrical Joist

STRESS ANALYSIS - PAGE 3



NEW MILLENNIUM
BUILDING SYSTEMS

Job Number: 8010-0704	Job Name: 10-123 BARRHAVEN FIRE STATION - SHOPORDERS	Date Run: 11/19/2010 3:57:07 PM
Location: OTTAWA, ON	Joist Description: Short Span Crimp 20K616/281	Mark: TJ05

TCX Design

TCX Left		TCX Right	
TCX Length	0-0	TCX Length	0-0 1/2
TCX Type	R	TCX Type	R
TCX Depth	4	TCX Depth	4
BPL Length	0-4	BPL Length	0-10 3/8
Clear Bearing	0-4 1/8	Clear Bearing	0-5 5/8
BPL Material: 69L = 2 x 3 x .250		BPL Material: 27 = 2 1/2 x 2 1/2 x .250	

Total Load	615.00	Total Load	615.00
Reqd TL Def L/80	0.00	Reqd TL Def L/80	0.01
Live Load	421.50	Live Load	421.50
Reqd LL Def L/120	0.00	Reqd LL Def L/120	0.00
Section Modulus	0.0000	Section Modulus	0.1568
Reqd SM	0.0000	Reqd SM	0.0002
Mom of Inertia	0.0000	Mom of Inertia	0.1685
Reqd MI	0.0000	Reqd MI	0.0000

Seat Type: Lapped

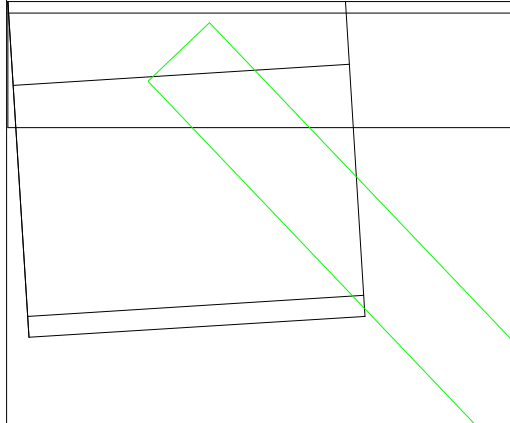

Seat Type: Pegged or Butted

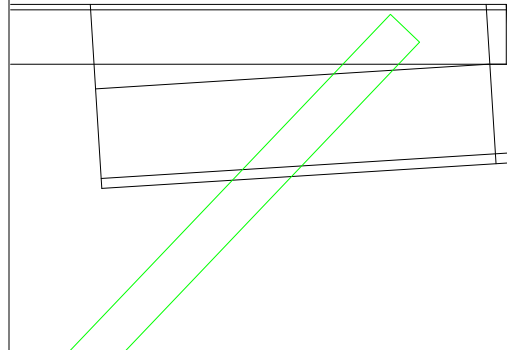

LSD Design

- | | |
|--|--|
| Case 1a: DL | Case 6a: 1.25(DL)+0.5(CL+SL)+1.4(WL+AX)+0.8(TL) |
| Case 1b: 1.4(DL) | Case 6b: 1.25(DL)+0.5(CL+SL)+1.4(WL-AX)+0.8(TL) |
| Case 2a: LL | Case 6c: 1.25(DL)+0.5(CL+SL)+1.4(WL+AX+IP)+0.8(TL) |
| Case 2b: SL | Case 6d: 1.25(DL)+0.5(CL+SL)+1.4(WL-AX+IP)+0.8(TL) |
| Case 3a: 1.25(DL+CL)+1.5(TL+LL) | Case 7a: 1.25(DL+CL)+0.4(WL+AX)+1.5(TL+LL) |
| Case 3b: 1.25(DL+CL)+1.5(TL+SL) | Case 7b: 1.25(DL+CL)+0.4(WL-AX)+1.5(TL+LL) |
| Case 3c: 1.25(DL+CL)+1.5(TL+LL+FEM) | Case 7c: 1.25(DL+CL)+0.4(WL+AX+IP)+1.5(TL+LL) |
| Case 3d: 1.25(DL+CL)+1.5(TL+SL+FEM) | Case 7d: 1.25(DL+CL)+0.4(WL-AX+IP)+1.5(TL+LL) |
| Case 3e: DL+CL+TL+LL | Case 8a: 1.25(DL+CL)+0.4(WL+AX)+1.5(TL+SL) |
| Case 3f: DL+CL+TL+SL | Case 8b: 1.25(DL+CL)+0.4(WL-AX)+1.5(TL+SL) |
| Case 4a: 1.25(DL)+0.5(CL+LL)+1.4(WL+AX)+0.8(TL) | Case 8c: 1.25(DL+CL)+0.4(WL+AX+IP)+1.5(TL+SL) |
| Case 4b: 1.25(DL)+0.5(CL+LL)+1.4(WL-AX)+0.8(TL) | Case 8d: 1.25(DL+CL)+0.4(WL-AX+IP)+1.5(TL+SL) |
| Case 4c: 1.25(DL)+0.5(CL+LL)+1.4(WL+AX+IP)+0.8(TL) | Case 9a: DL+CL+0.5(LL)+0.7(TL)+SM+AX+FEM |
| Case 4d: 1.25(DL)+0.5(CL+LL)+1.4(WL-AX+IP)+0.8(TL) | Case 9b: DL+CL+0.5(LL)+0.7(TL)+SM-AX+FEM |
| Case 4e: 1.25(DL+CL)+1.4(WL+AX)+1.1(TL)+LL | Case 9c: DL+CL+0.25(SL)+0.7(TL)+SM+AX+FEM |
| Case 4f: 1.25(DL+CL)+1.4(WL-AX)+1.1(TL)+LL | Case 9d: DL+CL+0.25(SL)+0.7(TL)+SM-AX+FEM |
| Case 5a: 0.9(DL)+1.4(WL+AX) | Case 9e: DL+CL+LL+1.1(TL)+SM+AX+FEM |
| Case 5b: 0.9(DL)+1.4(WL-AX) | Case 9f: DL+CL+LL+1.1(TL)+SM-AX+FEM |
| Case 5c: 0.9(DL)+1.4(WL+AX+IP) | Case 10a: DL+SM+AX |
| Case 5d: 0.9(DL)+1.4(WL-AX+IP) | Case 10b: DL+SM-AX |
| Case 5e: DL+SM+AX | Case 10c: DL+CL+SM+AX |
| Case 5f: DL+SM-AX | Case 10d: DL+CL+SM-AX |

STRESS ANALYSIS - PAGE 1



NEW MILLENNIUM
BUILDING SYSTEMS

Job Number: 8010-0704	Job Name: 10-123 BARRHAVEN FIRE STATION - SHOPORDERS	Date Run: 11/19/2010 3:57:07 PM
Location: OTTAWA, ON	Joist Description: Short Span Crimp 20K616/281	Mark: TJ08

Geometry

Base Length: 22-6 5/8	Working Length: 22-2 5/8	Joist Depth: 20.00	Effective Depth: 19.00	BC Panel Length: 5 @ 4-0	Shape: Parallel Chords
---------------------------------	------------------------------------	------------------------------	----------------------------------	------------------------------------	----------------------------------

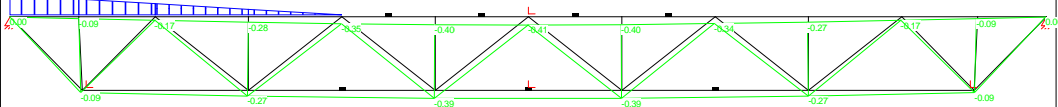
Variable	Left End	Right End	Deflection Case 2a: LL (Max Deflection: -0.41 in-Y, -0.06 in-X) 
BC Panel	1-8 5/8	1-8 5/8	
TC Panel	1-7 3/4	1-7 3/4	
First Half	1-6 3/4	1-6 5/8	
First Diag.	3-3 3/8	3-3 1/4	
Depth	20.00	20.00	

Loads, *** All loads are factored ***

Load Type	Category	Load1	Load2	Position	Direction	Loc/Begin	Sp/End
Uniform (plf)	DL	193.50	193.50	TC	+	0-0	22-6 5/8
Uniform (plf)	LL	421.50	421.50	TC	+	0-0	22-6 5/8
Uniform (plf)	TL	234.00	0.00	TC	+	<0-2 1/4>	6-7 3/4
Axial (lbs)	WL	24,750.00	0.00	TC	+	0-0	0-0
Conc anywhere (lbs)	TL	315.00	0.00	BC	+	11-3 3/8	0-0
Net Uplift (plf)	WL	197.00	197.00	TC	-	0-0	22-6 5/8
Conc anywhere (lbs)	TL	315.00	0.00	TC	+	11-3 3/8	0-0

Stress Analysis Summary

Int. Panel TC: 24.00	Max Panel BC: 48.00	Reaction LE: 8,193.12	Reaction RE: 7,542.58	Minimum Shear: 2,048.28	Max TC Comp.: 44,508.89	Max BC Tension 26,595.03
--------------------------------	-------------------------------	---------------------------------	---------------------------------	-----------------------------------	-----------------------------------	------------------------------------

Member	TC Tension	TC Compression	BC Tension	BC Compression	Web Tension	Web Comp.	Web Length	PP Dist.
W2	26,811.72	30,217.89	0.00	0.00	10,606.83	2,945.08	26.61	0-2
V1S	26,797.22	30,174.17	0.00	0.00	316.16	2,049.31	19.02	1-7 3/4
W3	26,797.22	30,174.17	13,023.31	3,811.03	2,511.04	8,774.08	26.69	1-8 5/8
W4	30,353.07	39,282.82	13,023.31	3,811.03	7,948.79	2,288.97	30.61	3-3 3/8
W5	30,353.07	39,282.82	23,120.94	6,882.73	1,635.46	5,784.58	30.61	5-3 3/8
W6	32,399.98	44,508.89	23,120.94	6,882.73	3,802.85	981.96	30.61	7-3 3/8
W7	32,399.98	44,508.89	26,595.03	7,904.84	907.50	3,300.11	30.61	9-3 3/8

* Symmetrical Joist

Standard Verticals

Member	Position	Max Tension	Max Comp.	Length
V2	Interior	438.50	2,214.11	19.00

STRESS ANALYSIS - PAGE 2



NEW MILLENNIUM
BUILDING SYSTEMS

Job Number: 8010-0704	Job Name: 10-123 BARRHAVEN FIRE STATION - SHOPORDERS	Date Run: 11/19/2010 3:57:07 PM
Location: OTTAWA, ON	Joist Description: Short Span Crimp 20K616/281	Mark: TJ08

Chord Properties

Chord	Area	Rx	Rz	Ryy	Y	Ix	Q	Material
TC	0.6208	0.6001	0.3508	1.2870	0.5761	0.2235	1.0000	A34 = 1.9375 x .176
BC	0.3922	0.4635	0.2955	1.0914	0.4256	0.0843	0.9945	10 = 1 1/2 x 1 1/2 x .137

Axial and Bending Analysis

K: 1.00	Fy: 50,000.00	Fb: 45,000.00	Mom of Inertia: 173.82	LL 360: 592.02	LL 240: 888.03	Max Bridg TC: 15-6 5/8	Max Bridg BC: 12-0 3/8
-------------------	-------------------------	-------------------------	----------------------------------	--------------------------	--------------------------	----------------------------------	----------------------------------

Top Chord Check	End Panel LE	First Panel LE	Interior Panel	First Panel RE	End Panel RE	Gap Between Chords: 1.1250
Length	17.75	19.63	24.00	19.50	17.75	Min Weld Len 2X: 0.5000
Bending Load	806.39	0.00	0.00	0.00	596.72	Max Load Fillers TC: 49,707.06
Axial Load	30,217.89	30,174.17	44,508.89	29,829.14	29,863.06	Max Load no Fillers TC: 39,713.25
fa	24,339.03	24,303.82	35,849.72	24,025.91	24,053.23	TC OAL/Ryy: 207.1611
Maximum K L/r	50.59	55.94	40.00	55.58	50.59	BC Stress: 42,828.21
Fcr	41,466.14	39,775.49	44,480.71	39,891.21	41,466.14	BC L/Rz: 162.4212
Fa	37,319.52	35,797.94	40,032.64	35,902.09	37,319.52	TC Shear Stress: 15,148.10
F'e	327,098.69	267,581.56	178,917.59	271,023.09	327,098.69	BC Shear Stress: 19,026.76
Cm	0.9752	0.9697	0.9109	0.9705	0.9755	
Panel Point Moment	2924.35	700.00	700.00	700.00	2326.55	
Mid Panel Moment	2248.21	590.63	590.63	590.63	1826.54	
Panel Point fb	8905.85	2131.79	2131.79	2131.79	7085.31	
Mid Panel fb	2897.33	761.15	761.15	761.15	2353.91	
Fillers	0	0	4	0	0	
Panel Point Stress	33,244.88	26,435.61	37,981.51	26,157.70	31,138.54	
Mid Panel Stress	0.7130	0.6951	0.9131	0.6854	0.6939	

Web Design

Member	Web Tension	Allow Tension	Web Comp	Allow Comp	Weld	Qty	Material
W2	10,606.83	10,682.16	2,945.08	7,195.38	4.54 x 0.105	1	C16 = 1.125 x 0.943 x .105
W3	2,511.04	16,459.83	8,774.08	9,274.62	2.94 x 0.134	1	C22 = 1.125 x 1.086 x .134
W4	7,948.79	8,461.40	2,288.97	2,698.49	3.97 x 0.090	1	C12 = 1.125 x 0.715 x .090
W5	1,635.46	11,869.06	5,784.58	6,080.55	2.47 x 0.105	1	C16 = 1.125 x 0.943 x .105
W6	3,802.85	7,215.59	981.96	2,244.19	2.23 x 0.077	1	C10 = 1.125 x 0.700 x 0.07
W7	907.50	11,869.06	3,300.11	6,080.55	2.00 x 0.105	1	C16 = 1.125 x 0.943 x .105
V1	316.16	7,215.59	2,049.31	4,431.69	2.00 x 0.077	1	C10 = 1.125 x 0.700 x 0.07
V2	438.50	7,215.59	2,214.11	4,435.73	2.00 x 0.077	1	C10 = 1.125 x 0.700 x 0.07

* Symmetrical Joist

STRESS ANALYSIS - PAGE 3



NEW MILLENNIUM
BUILDING SYSTEMS

Job Number: 8010-0704	Job Name: 10-123 BARRHAVEN FIRE STATION - SHOPORDERS	Date Run: 11/19/2010 3:57:07 PM
Location: OTTAWA, ON	Joist Description: Short Span Crimp 20K616/281	Mark: TJ08

TCX Design

TCX Left		TCX Right	
TCX Length	0-2 1/4	TCX Length	0-0
TCX Type	R	TCX Type	R
TCX Depth	4	TCX Depth	4
BPL Length	0-6 1/4	BPL Length	0-4
Clear Bearing	0-6 3/8	Clear Bearing	0-5 1/8
BPL Material: 69L = 2 x 3 x .250		BPL Material: 69L = 2 x 3 x .250	

Total Load	615.00	Total Load	615.00
Reqd TL Def L/80	0.03	Reqd TL Def L/80	0.00
Live Load	421.50	Live Load	421.50
Reqd LL Def L/120	0.02	Reqd LL Def L/120	0.00
Section Modulus	0.3284	Section Modulus	0.0000
Reqd SM	0.0031	Reqd SM	0.0000
Mom of Inertia	0.4470	Mom of Inertia	0.0000
Reqd MI	0.0001	Reqd MI	0.0000

Seat Type: Lapped

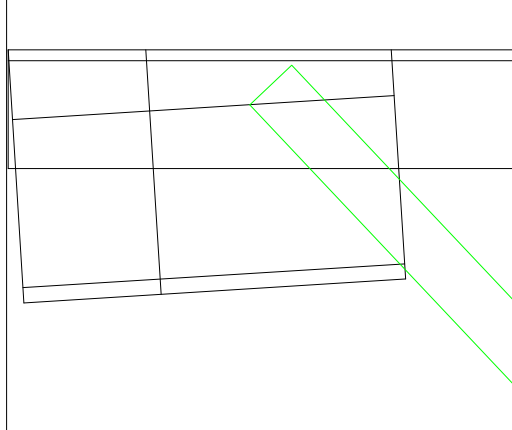

Seat Type: Lapped

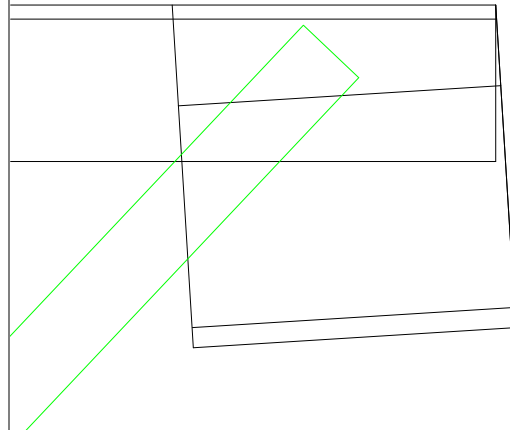

LSD Design

- | | |
|--|--|
| Case 1a: DL | Case 6a: 1.25(DL)+0.5(CL+SL)+1.4(WL+AX)+0.8(TL) |
| Case 1b: 1.4(DL) | Case 6b: 1.25(DL)+0.5(CL+SL)+1.4(WL-AX)+0.8(TL) |
| Case 2a: LL | Case 6c: 1.25(DL)+0.5(CL+SL)+1.4(WL+AX+IP)+0.8(TL) |
| Case 2b: SL | Case 6d: 1.25(DL)+0.5(CL+SL)+1.4(WL-AX+IP)+0.8(TL) |
| Case 3a: 1.25(DL+CL)+1.5(TL+LL) | Case 7a: 1.25(DL+CL)+0.4(WL+AX)+1.5(TL+LL) |
| Case 3b: 1.25(DL+CL)+1.5(TL+SL) | Case 7b: 1.25(DL+CL)+0.4(WL-AX)+1.5(TL+LL) |
| Case 3c: 1.25(DL+CL)+1.5(TL+LL+FEM) | Case 7c: 1.25(DL+CL)+0.4(WL+AX+IP)+1.5(TL+LL) |
| Case 3d: 1.25(DL+CL)+1.5(TL+SL+FEM) | Case 7d: 1.25(DL+CL)+0.4(WL-AX+IP)+1.5(TL+LL) |
| Case 3e: DL+CL+TL+LL | Case 8a: 1.25(DL+CL)+0.4(WL+AX)+1.5(TL+SL) |
| Case 3f: DL+CL+TL+SL | Case 8b: 1.25(DL+CL)+0.4(WL-AX)+1.5(TL+SL) |
| Case 4a: 1.25(DL)+0.5(CL+LL)+1.4(WL+AX)+0.8(TL) | Case 8c: 1.25(DL+CL)+0.4(WL+AX+IP)+1.5(TL+SL) |
| Case 4b: 1.25(DL)+0.5(CL+LL)+1.4(WL-AX)+0.8(TL) | Case 8d: 1.25(DL+CL)+0.4(WL-AX+IP)+1.5(TL+SL) |
| Case 4c: 1.25(DL)+0.5(CL+LL)+1.4(WL+AX+IP)+0.8(TL) | Case 9a: DL+CL+0.5(LL)+0.7(TL)+SM+AX+FEM |
| Case 4d: 1.25(DL)+0.5(CL+LL)+1.4(WL-AX+IP)+0.8(TL) | Case 9b: DL+CL+0.5(LL)+0.7(TL)+SM-AX+FEM |
| Case 4e: 1.25(DL+CL)+1.4(WL+AX)+1.1(TL)+LL | Case 9c: DL+CL+0.25(SL)+0.7(TL)+SM+AX+FEM |
| Case 4f: 1.25(DL+CL)+1.4(WL-AX)+1.1(TL)+LL | Case 9d: DL+CL+0.25(SL)+0.7(TL)+SM-AX+FEM |
| Case 5a: 0.9(DL)+1.4(WL+AX) | Case 9e: DL+CL+LL+1.1(TL)+SM+AX+FEM |
| Case 5b: 0.9(DL)+1.4(WL-AX) | Case 9f: DL+CL+LL+1.1(TL)+SM-AX+FEM |
| Case 5c: 0.9(DL)+1.4(WL+AX+IP) | Case 10a: DL+SM+AX |
| Case 5d: 0.9(DL)+1.4(WL-AX+IP) | Case 10b: DL+SM-AX |
| Case 5e: DL+SM+AX | Case 10c: DL+CL+SM+AX |
| Case 5f: DL+SM-AX | Case 10d: DL+CL+SM-AX |

STRESS ANALYSIS - PAGE 1



NEW MILLENNIUM
BUILDING SYSTEMS

Job Number: 8010-0704	Job Name: 10-123 BARRHAVEN FIRE STATION - SHOPORDERS	Date Run: 11/19/2010 4:00:09 PM
Location: OTTAWA, ON	Joist Description: Short Span Crimp 20K551/251	Mark: TJ15

Geometry

Base Length: 18-2 3/4	Working Length: 17-10 3/4	Joist Depth: 20.00	Effective Depth: 18.80	BC Panel Length: 4 @ 4-0	Shape: Parallel Chords
---------------------------------	-------------------------------------	------------------------------	----------------------------------	------------------------------------	----------------------------------

Variable	Left End	Right End
BC Panel	1-8 3/8	1-8 3/8
TC Panel	1-6 5/8	1-6 5/8
First Half	1-5	1-5
First Diag.	3-1 3/8	3-1 3/8
Depth	20.00	20.00

Deflection Case 2a: LL (Max Deflection: -0.25 in-Y, -0.05 in-X)

Loads, *** All loads are factored ***

Load Type	Category	Load1	Load2	Position	Direction	Loc/Begin	Sp/End
Uniform (plf)	DL	174.50	174.50	TC	+	0-0	18-2 3/4
Uniform (plf)	LL	376.50	376.50	TC	+	0-0	18-2 3/4
Uniform (plf)	LL	238.00	883.00	TC	+	0-0	18-9 3/8
Axial (lbs)	WL	19,125.00	0.00	TC	+	0-0	0-0
Net Uplift (plf)	WL	204.00	204.00	TC	-	0-0	18-2 3/4
Conc Load (lbs)	LL	1,700.00	0.00	TC	+	5-0	11-0
Conc Load (lbs)	LL	3,375.00	0.00	TC	+	9-0	15-0
Conc anywhere (lbs)	TL	315.00	0.00	TC	+	9-1 3/8	0-0
Conc anywhere (lbs)	TL	315.00	0.00	BC	+	9-1 3/8	0-0
Conc Load (lbs)	LL	1,700.00	0.00	TC	+	12-0	18-0

Stress Analysis Summary

Int. Panel TC: 24.00	Max Panel BC: 48.00	Reaction LE: 13,114.19	Reaction RE: 16,980.12	Minimum Shear: 4,245.03	Max TC Comp.: 53,444.22	Max BC Tension: 44,239.38
--------------------------------	-------------------------------	----------------------------------	----------------------------------	-----------------------------------	-----------------------------------	-------------------------------------

Member	TC Tension	TC Compression	BC Tension	BC Compression	Web Tension	Web Comp.	Web Length	PP Dist.
W2	20,813.13	28,674.38	0.00	0.00	22,366.03	2,415.21	26.29	0-2
V1S	20,784.42	28,539.95	0.00	0.00	309.74	8,242.67	18.88	1-6 5/8
W3	20,784.42	28,539.95	24,129.63	2,942.36	1,912.89	18,330.77	25.35	1-8 3/8
W4	23,402.82	44,559.04	24,129.63	2,942.36	18,224.35	1,696.45	30.49	3-1 3/8
W5	23,402.82	44,559.04	44,239.38	5,079.10	3,024.11	11,845.14	30.49	5-1 3/8
W6	24,471.19	53,444.22	44,239.38	5,079.10	8,474.16	3,279.74	30.49	7-1 3/8
V3	24,471.19	53,444.22	44,239.38	5,079.10	5,547.36	8,195.22	18.80	9-1 3/8

* Symmetrical Joist

Standard Verticals

Member	Position	Max Tension	Max Comp.	Length
V2	Interior	5,547.36	8,483.56	18.80

STRESS ANALYSIS - PAGE 2



NEW MILLENNIUM
BUILDING SYSTEMS

Job Number: 8010-0704	Job Name: 10-123 BARRHAVEN FIRE STATION - SHOPORDERS	Date Run: 11/19/2010 4:00:09 PM
Location: OTTAWA, ON	Joist Description: Short Span Crimp 20K551/251	Mark: TJ15

Chord Properties

Chord	Area	Rx	Rz	Ryy	Y	Ix	Q	Material
TC	0.8173	0.6134	0.3924	1.2963	0.5795	0.3076	1.0000	20 = 2 x 2 x .216
BC	0.7155	0.6489	0.3818	1.3483	0.6194	0.3013	1.0000	A36 = 2.0938 x .187

Axial and Bending Analysis

K: 1.00	Fy: 50,000.00	Fb: 45,000.00	Mom of Inertia: 270.33	LL 300: 2,114.58	TL 480: 1,321.61	Max Bridg TC: 15-8	Max Bridg BC: 26-11 5/8
-------------------	-------------------------	-------------------------	----------------------------------	----------------------------	----------------------------	------------------------------	-----------------------------------

Top Chord Check	End Panel LE	First Panel LE	Interior Panel	First Panel RE	End Panel RE	Gap Between Chords: 1.1250
Length	16.63	18.75	24.00	18.75	16.63	Min Weld Len 2X: 0.5000
Bending Load	782.83	835.96	1,116.41	1,324.77	1,377.90	Max Load Fillers TC: 62,568.33
Axial Load	27,336.91	27,252.06	53,444.22	28,539.95	28,674.38	Max Load no Fillers TC: 53,326.26
fa	16,723.02	16,671.11	32,693.84	17,458.96	17,541.19	TC OAL/Ryy: 165.6659
Maximum K L/r	42.36	47.78	39.13	47.78	42.36	BC Stress: 34,340.34
Fcr	43,851.24	42,313.84	44,705.54	42,313.84	43,851.24	BC L/Rz: 125.7236
Fa	39,466.11	38,082.45	40,234.98	38,082.45	39,466.11	TC Shear Stress: 19,120.75
F'e	389,661.16	306,342.94	186,976.89	306,342.94	389,661.16	BC Shear Stress: 27,377.16
Cm	0.9857	0.9819	0.9223	0.9810	0.9850	
Panel Point Moment	2532.39	2730.74	5165.63	3918.20	3978.58	
Mid Panel Moment	1972.29	1282.51	2823.44	1687.09	3038.73	
Panel Point fb	5848.41	6306.48	11929.69	9048.84	9188.29	
Mid Panel fb	1858.00	1208.19	2659.83	1589.32	2862.64	
Fillers	0	0	2	0	0	
Panel Point Stress	22,571.42	22,977.58	44,623.53	26,507.80	26,729.48	
Mid Panel Stress	0.4617	0.4627	0.8727	0.4913	0.5031	

Web Design

Member	Web Tension	Allow Tension	Web Comp	Allow Comp	Weld	Qty	Material
W2	22,366.03	22,785.30	2,415.21	15,261.15	6.16 x 0.163	1	C32 = 1.125 x 1.479 x .163
W3	1,912.89	36,889.49	18,330.77	20,903.20	4.39 x 0.188	1	C38 = 1.125 x 1.844 x .200
W4	18,224.35	21,718.85	1,696.45	11,921.07	5.45 x 0.150	1	C28 = 1.125 x 1.347 x .150
W5	3,024.11	21,718.85	11,845.14	11,921.07	3.55 x 0.150	1	C28 = 1.125 x 1.347 x .150
W6	8,474.16	11,869.06	3,279.74	6,329.97	3.62 x 0.105	1	C16 = 1.125 x 0.943 x .105
V1	309.74	13,593.73	8,242.67	9,309.11	3.22 x 0.115	1	C18 = 1.125 x 1.012 x .115
V2	5,547.36	7,215.59	8,483.56	4,586.17	2.65 x 0.077	1	C10 = 1.125 x 0.700 x 0.07

* Symmetrical Joist

STRESS ANALYSIS - PAGE 3



NEW MILLENNIUM
BUILDING SYSTEMS

<i>Job Number:</i> 8010-0704	<i>Job Name:</i> 10-123 BARRHAVEN FIRE STATION - SHOPORDERS	<i>Date Run:</i> 11/19/2010 4:00:09 PM
<i>Location:</i> OTTAWA, ON	<i>Joist Description:</i> Short Span Crimp 20K551/251	<i>Mark:</i> TJ15

TCX Design

TCX Left		TCX Right	
TCX Length	0-0	TCX Length	0-0
TCX Type	R	TCX Type	R
TCX Depth	4	TCX Depth	4
BPL Length	0-4	BPL Length	0-4
Clear Bearing	0-4 5/8	Clear Bearing	0-4 1/4
BPL Material: 69L = 2 x 3 x .250		BPL Material: 69L = 2 x 3 x .250	

Total Load	551.00	Total Load	551.00
Reqd TL Def L/80	0.00	Reqd TL Def L/80	0.00
Live Load	376.50	Live Load	376.50
Reqd LL Def L/120	0.00	Reqd LL Def L/120	0.00
Section Modulus	0.0000	Section Modulus	0.0000
Reqd SM	0.0000	Reqd SM	0.0000
Mom of Inertia	0.0000	Mom of Inertia	0.0000
Reqd MI	0.0000	Reqd MI	0.0000

Seat Type: Lapped

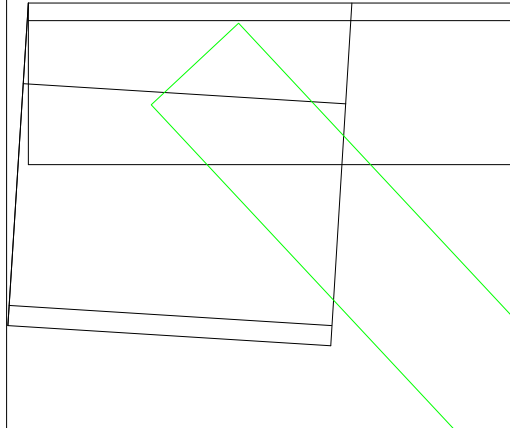

Seat Type: Lapped

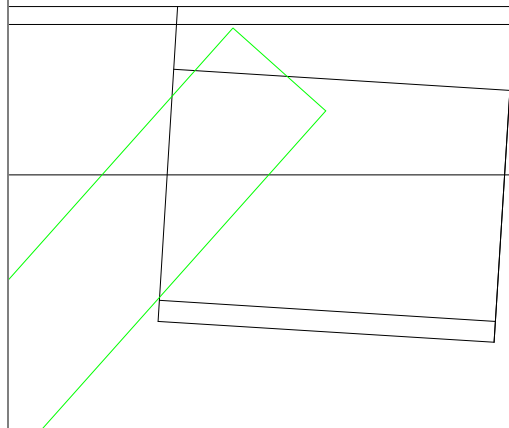

LSD Design

- | | |
|--|--|
| Case 1a: DL | Case 6a: 1.25(DL)+0.5(CL+SL)+1.4(WL+AX)+0.8(TL) |
| Case 1b: 1.4(DL) | Case 6b: 1.25(DL)+0.5(CL+SL)+1.4(WL-AX)+0.8(TL) |
| Case 2a: LL | Case 6c: 1.25(DL)+0.5(CL+SL)+1.4(WL+AX+IP)+0.8(TL) |
| Case 2b: SL | Case 6d: 1.25(DL)+0.5(CL+SL)+1.4(WL-AX+IP)+0.8(TL) |
| Case 3a: 1.25(DL+CL)+1.5(TL+LL) | Case 7a: 1.25(DL+CL)+0.4(WL+AX)+1.5(TL+LL) |
| Case 3b: 1.25(DL+CL)+1.5(TL+SL) | Case 7b: 1.25(DL+CL)+0.4(WL-AX)+1.5(TL+LL) |
| Case 3c: 1.25(DL+CL)+1.5(TL+LL+FEM) | Case 7c: 1.25(DL+CL)+0.4(WL+AX+IP)+1.5(TL+LL) |
| Case 3d: 1.25(DL+CL)+1.5(TL+SL+FEM) | Case 7d: 1.25(DL+CL)+0.4(WL-AX+IP)+1.5(TL+LL) |
| Case 3e: DL+CL+TL+LL | Case 8a: 1.25(DL+CL)+0.4(WL+AX)+1.5(TL+SL) |
| Case 3f: DL+CL+TL+SL | Case 8b: 1.25(DL+CL)+0.4(WL-AX)+1.5(TL+SL) |
| Case 4a: 1.25(DL)+0.5(CL+LL)+1.4(WL+AX)+0.8(TL) | Case 8c: 1.25(DL+CL)+0.4(WL+AX+IP)+1.5(TL+SL) |
| Case 4b: 1.25(DL)+0.5(CL+LL)+1.4(WL-AX)+0.8(TL) | Case 8d: 1.25(DL+CL)+0.4(WL-AX+IP)+1.5(TL+SL) |
| Case 4c: 1.25(DL)+0.5(CL+LL)+1.4(WL+AX+IP)+0.8(TL) | Case 9a: DL+CL+0.5(LL)+0.7(TL)+SM+AX+FEM |
| Case 4d: 1.25(DL)+0.5(CL+LL)+1.4(WL-AX+IP)+0.8(TL) | Case 9b: DL+CL+0.5(LL)+0.7(TL)+SM-AX+FEM |
| Case 4e: 1.25(DL+CL)+1.4(WL+AX)+1.1(TL)+LL | Case 9c: DL+CL+0.25(SL)+0.7(TL)+SM+AX+FEM |
| Case 4f: 1.25(DL+CL)+1.4(WL-AX)+1.1(TL)+LL | Case 9d: DL+CL+0.25(SL)+0.7(TL)+SM-AX+FEM |
| Case 5a: 0.9(DL)+1.4(WL+AX) | Case 9e: DL+CL+LL+1.1(TL)+SM+AX+FEM |
| Case 5b: 0.9(DL)+1.4(WL-AX) | Case 9f: DL+CL+LL+1.1(TL)+SM-AX+FEM |
| Case 5c: 0.9(DL)+1.4(WL+AX+IP) | Case 10a: DL+SM+AX |
| Case 5d: 0.9(DL)+1.4(WL-AX+IP) | Case 10b: DL+SM-AX |
| Case 5e: DL+SM+AX | Case 10c: DL+CL+SM+AX |
| Case 5f: DL+SM-AX | Case 10d: DL+CL+SM-AX |

STRESS ANALYSIS - PAGE 1



NEW MILLENNIUM
BUILDING SYSTEMS

Job Number: 8010-0704	Job Name: 10-123 BARRHAVEN FIRE STATION - SHOPORDERS	Date Run: 11/19/2010 4:00:23 PM
Location: OTTAWA, ON	Joist Description: Short Span Crimp 20K630/288	Mark: TJ17

Geometry

Base Length: 18-5 3/8	Working Length: 18-1 3/8	Joist Depth: 20.00	Effective Depth: 18.85	BC Panel Length: 4 @ 4-0	Shape: Parallel Chords
---------------------------------	------------------------------------	------------------------------	----------------------------------	------------------------------------	----------------------------------

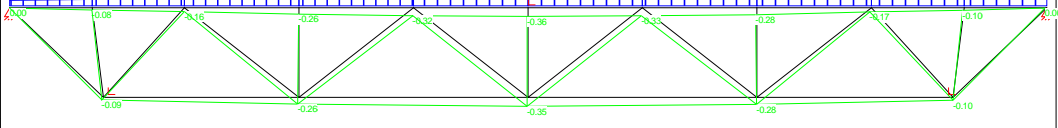
Variable	Left End	Right End	Deflection Case 2a: LL (Max Deflection: -0.36 in-Y, -0.07 in-X) 
BC Panel	1-9 5/8	1-9 5/8	
TC Panel	1-7 1/4	1-7 1/4	
First Half	1-5	1-5 1/8	
First Diag.	3-2 5/8	3-2 3/4	
Depth	20.00	20.00	

Loads, *** All loads are factored ***

Load Type	Category	Load1	Load2	Position	Direction	Loc/Begin	Sp/End
Uniform (plf)	DL	198.00	198.00	TC	+	0-0	18-5 3/8
Uniform (plf)	LL	432.00	432.00	TC	+	0-0	18-5 3/8
Uniform (plf)	LL	238.00	883.00	TC	+	<0-0 1/4>	18-9 1/8
Net Uplift (plf)	WL	204.00	204.00	TC	-	0-0	18-5 3/8
Conc anywhere (lbs)	TL	315.00	0.00	BC	+	9-2 5/8	0-0
Conc anywhere (lbs)	TL	315.00	0.00	TC	+	9-2 5/8	0-0

Stress Analysis Summary

Int. Panel TC: 24.00	Max Panel BC: 48.00	Reaction LE: 10,416.43	Reaction RE: 12,382.73	Minimum Shear: 3,095.68	Max TC Comp.: 32,903.50	Max BC Tension: 31,586.88
--------------------------------	-------------------------------	----------------------------------	----------------------------------	-----------------------------------	-----------------------------------	-------------------------------------

Member	TC Tension	TC Compression	BC Tension	BC Compression	Web Tension	Web Comp.	Web Length	PP Dist.
W2	1,822.78	11,451.72	0.00	0.00	16,319.86	2,527.27	27.21	0-2
V1S	1,782.41	11,169.99	0.00	0.00	324.01	3,000.11	19.00	1-7 1/4
W3	1,782.41	11,169.99	19,131.41	3,080.76	1,930.93	12,110.97	25.38	1-9 5/8
W4	4,416.02	27,056.46	19,131.41	3,080.76	10,527.15	1,701.33	30.52	3-2 5/8
W5	4,416.02	27,056.46	31,586.88	5,216.61	1,021.50	6,921.40	30.52	5-2 5/8
W6	5,482.55	32,903.50	31,586.88	5,216.61	5,012.18	769.67	30.52	7-2 5/8

* Symmetrical Joist

Standard Verticals

Member	Position	Max Tension	Max Comp.	Length
V2	Interior	435.43	3,460.00	18.85

STRESS ANALYSIS - PAGE 2



NEW MILLENNIUM
BUILDING SYSTEMS

Job Number: 8010-0704	Job Name: 10-123 BARRHAVEN FIRE STATION - SHOPORDERS	Date Run: 11/19/2010 4:00:23 PM
Location: OTTAWA, ON	Joist Description: Short Span Crimp 20K630/288	Mark: TJ17

Chord Properties

Chord	Area	Rx	Rz	Ryy	Y	Ix	Q	Material
TC	0.6208	0.6001	0.3508	1.2870	0.5761	0.2235	1.0000	A34 = 1.9375 x .176
BC	0.6208	0.6001	0.3508	1.2870	0.5761	0.2235	1.0000	A34 = 1.9375 x .176

Axial and Bending Analysis

K: 1.00	Fy: 50,000.00	Fb: 45,000.00	Mom of Inertia: 220.97	LL 300: 1,666.59	TL 480: 1,041.62	Max Bridg TC: 15-6 5/8	Max Bridg BC: 23-11
-------------------	-------------------------	-------------------------	----------------------------------	----------------------------	----------------------------	----------------------------------	-------------------------------

Top Chord Check	End Panel LE	First Panel LE	Interior Panel	First Panel RE	End Panel RE	Gap Between Chords: 1.1250
Length	17.25	19.38	24.00	19.50	17.25	Min Weld Len 2X: 0.5000
Bending Load	859.97	914.30	1,192.30	1,399.26	1,453.78	Max Load Fillers TC: 45,766.25
Axial Load	9,877.02	9,699.96	32,903.50	11,169.99	11,451.72	Max Load no Fillers TC: 36,663.55
fa	7,955.45	7,812.84	26,502.15	8,996.88	9,223.80	TC OAL/Ryy: 168.8951
Maximum K L/r	49.17	55.22	68.41	55.58	49.17	BC Stress: 29,705.26
Fcr	41,899.42	40,006.52	35,512.37	39,891.21	41,899.42	BC L/Rz: 136.8117
Fa	37,709.48	36,005.87	31,961.13	35,902.09	37,709.48	TC Shear Stress: 22,664.77
F'e	346,335.75	274,531.44	178,917.59	271,023.09	346,335.75	BC Shear Stress: 22,664.77
Cm	0.9923	0.9905	0.9342	0.9889	0.9911	
Panel Point Moment	2934.27	3123.94	5469.19	4438.93	4539.54	
Mid Panel Moment	2237.92	1444.00	2975.22	1940.57	3363.37	
Panel Point fb	8936.08	9513.69	16655.94	13518.38	13824.78	
Mid Panel fb	2884.07	1860.92	3834.24	2500.86	4334.46	
Fillers	0	0	0	0	0	
Panel Point Stress	16,891.53	17,326.53	43,158.09	22,515.26	23,048.58	
Mid Panel Stress	0.2690	0.2546	0.9139	0.3013	0.3320	

Web Design

Member	Web Tension	Allow Tension	Web Comp	Allow Comp	Weld	Qty	Material
W2	16,319.86	19,546.97	2,527.27	12,930.10	4.88 x 0.150	1	C28 = 1.125 x 1.347 x .150
W3	1,930.93	21,718.85	12,110.97	12,763.80	3.62 x 0.150	1	C28 = 1.125 x 1.347 x .150
W4	10,527.15	11,869.06	1,701.33	6,241.79	4.50 x 0.105	1	C16 = 1.125 x 0.943 x .105
W5	1,021.50	13,593.73	6,921.40	7,593.62	2.70 x 0.115	1	C18 = 1.125 x 1.012 x .115
W6	5,012.18	7,215.59	769.67	2,344.51	2.93 x 0.077	1	C10 = 1.125 x 0.700 x 0.07
V1	324.01	7,215.59	3,000.11	4,506.92	2.00 x 0.077	1	C10 = 1.125 x 0.700 x 0.07
V2	435.43	7,215.59	3,460.00	4,536.14	2.00 x 0.077	1	C10 = 1.125 x 0.700 x 0.07

* Symmetrical Joist

STRESS ANALYSIS - PAGE 3



NEW MILLENNIUM
BUILDING SYSTEMS

Job Number: 8010-0704	Job Name: 10-123 BARRHAVEN FIRE STATION - SHOPORDERS	Date Run: 11/19/2010 4:00:23 PM
Location: OTTAWA, ON	Joist Description: Short Span Crimp 20K630/288	Mark: TJ17

TCX Design

TCX Left		TCX Right	
TCX Length	0-0 1/4	TCX Length	0-0
TCX Type	R	TCX Type	R
TCX Depth	4	TCX Depth	4
BPL Length	0-4 1/4	BPL Length	0-4
Clear Bearing	0-5 1/8	Clear Bearing	0-3 7/8
BPL Material: 69L = 2 x 3 x .250		BPL Material: 69L = 2 x 3 x .250	

Total Load	630.00	Total Load	630.00
Reqd TL Def L/80	0.00	Reqd TL Def L/80	0.00
Live Load	432.00	Live Load	432.00
Reqd LL Def L/120	0.00	Reqd LL Def L/120	0.00
Section Modulus	0.3284	Section Modulus	0.0000
Reqd SM	0.0000	Reqd SM	0.0000
Mom of Inertia	0.4470	Mom of Inertia	0.0000
Reqd MI	0.0000	Reqd MI	0.0000

Seat Type: Lapped

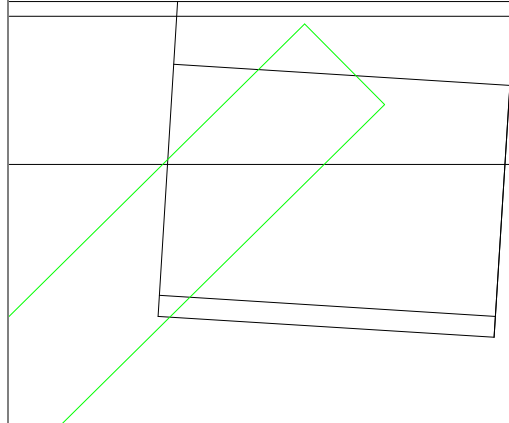
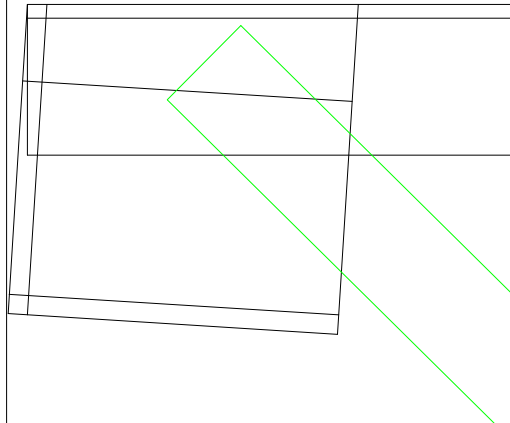

LSD Design

- | | |
|--|--|
| Case 1a: DL | Case 6a: 1.25(DL)+0.5(CL+SL)+1.4(WL+AX)+0.8(TL) |
| Case 1b: 1.4(DL) | Case 6b: 1.25(DL)+0.5(CL+SL)+1.4(WL-AX)+0.8(TL) |
| Case 2a: LL | Case 6c: 1.25(DL)+0.5(CL+SL)+1.4(WL+AX+IP)+0.8(TL) |
| Case 2b: SL | Case 6d: 1.25(DL)+0.5(CL+SL)+1.4(WL-AX+IP)+0.8(TL) |
| Case 3a: 1.25(DL+CL)+1.5(TL+LL) | Case 7a: 1.25(DL+CL)+0.4(WL+AX)+1.5(TL+LL) |
| Case 3b: 1.25(DL+CL)+1.5(TL+SL) | Case 7b: 1.25(DL+CL)+0.4(WL-AX)+1.5(TL+LL) |
| Case 3c: 1.25(DL+CL)+1.5(TL+LL+FEM) | Case 7c: 1.25(DL+CL)+0.4(WL+AX+IP)+1.5(TL+LL) |
| Case 3d: 1.25(DL+CL)+1.5(TL+SL+FEM) | Case 7d: 1.25(DL+CL)+0.4(WL-AX+IP)+1.5(TL+LL) |
| Case 3e: DL+CL+TL+LL | Case 8a: 1.25(DL+CL)+0.4(WL+AX)+1.5(TL+SL) |
| Case 3f: DL+CL+TL+SL | Case 8b: 1.25(DL+CL)+0.4(WL-AX)+1.5(TL+SL) |
| Case 4a: 1.25(DL)+0.5(CL+LL)+1.4(WL+AX)+0.8(TL) | Case 8c: 1.25(DL+CL)+0.4(WL+AX+IP)+1.5(TL+SL) |
| Case 4b: 1.25(DL)+0.5(CL+LL)+1.4(WL-AX)+0.8(TL) | Case 8d: 1.25(DL+CL)+0.4(WL-AX+IP)+1.5(TL+SL) |
| Case 4c: 1.25(DL)+0.5(CL+LL)+1.4(WL+AX+IP)+0.8(TL) | Case 9a: DL+CL+0.5(LL)+0.7(TL)+SM+AX+FEM |
| Case 4d: 1.25(DL)+0.5(CL+LL)+1.4(WL-AX+IP)+0.8(TL) | Case 9b: DL+CL+0.5(LL)+0.7(TL)+SM-AX+FEM |
| Case 4e: 1.25(DL+CL)+1.4(WL+AX)+1.1(TL)+LL | Case 9c: DL+CL+0.25(SL)+0.7(TL)+SM+AX+FEM |
| Case 4f: 1.25(DL+CL)+1.4(WL-AX)+1.1(TL)+LL | Case 9d: DL+CL+0.25(SL)+0.7(TL)+SM-AX+FEM |
| Case 5a: 0.9(DL)+1.4(WL+AX) | Case 9e: DL+CL+LL+1.1(TL)+SM+AX+FEM |
| Case 5b: 0.9(DL)+1.4(WL-AX) | Case 9f: DL+CL+LL+1.1(TL)+SM-AX+FEM |
| Case 5c: 0.9(DL)+1.4(WL+AX+IP) | Case 10a: DL+SM+AX |
| Case 5d: 0.9(DL)+1.4(WL-AX+IP) | Case 10b: DL+SM-AX |
| Case 5e: DL+SM+AX | Case 10c: DL+CL+SM+AX |
| Case 5f: DL+SM-AX | Case 10d: DL+CL+SM-AX |

STRESS ANALYSIS - PAGE 1



NEW MILLENNIUM
BUILDING SYSTEMS

Job Number: 8010-0704	Job Name: 10-123 BARRHAVEN FIRE STATION - SHOPORDERS	Date Run: 11/19/2010 4:00:33 PM
Location: OTTAWA, ON	Joist Description: Short Span Crimp 20K630/288	Mark: TJ18

Geometry

Base Length: 18-11 1/2	Working Length: 18-7 1/2	Joist Depth: 20.00	Effective Depth: 18.80	BC Panel Length: 4 @ 4-0	Shape: Parallel Chords
----------------------------------	------------------------------------	------------------------------	----------------------------------	------------------------------------	----------------------------------

Variable	Left End	Right End
BC Panel	1-9 1/4	1-9 1/4
TC Panel	1-8 7/8	1-8 7/8
First Half	1-8 1/2	1-8 1/2
First Diag.	3-5 3/4	3-5 3/4
Depth	20.00	20.00

Deflection Case 2a: LL (Max Deflection: -0.37 in-Y, -0.07 in-X)

Loads, *** All loads are factored ***

Load Type	Category	Load1	Load2	Position	Direction	Loc/Begin	Sp/End
Uniform (plf)	DL	198.00	198.00	TC	+	0-0	18-11 1/2
Uniform (plf)	LL	432.00	432.00	TC	+	0-0	18-11 1/2
Net Uplift (plf)	WL	204.00	204.00	TC	-	0-0	18-11 1/2
Uniform (plf)	LL	238.00	883.00	TC	+	0-0	18-9 3/8
Conc anywhere (lbs)	TL	315.00	0.00	BC	+	9-5 3/4	0-0
Conc anywhere (lbs)	TL	315.00	0.00	TC	+	9-5 3/4	0-0

Stress Analysis Summary

Int. Panel TC: 24.00	Max Panel BC: 48.00	Reaction LE: 10,693.27	Reaction RE: 12,714.25	Minimum Shear: 3,178.56	Max TC Comp.: 34,814.00	Max BC Tension: 33,502.73
--------------------------------	-------------------------------	----------------------------------	----------------------------------	-----------------------------------	-----------------------------------	-------------------------------------

Member	TC Tension	TC Compression	BC Tension	BC Compression	Web Tension	Web Comp.	Web Length	PP Dist.
W2	1,832.36	11,494.55	0.00	0.00	16,507.37	2,561.54	26.91	0-2
V1S	1,825.43	11,446.43	0.00	0.00	347.78	3,158.37	18.81	1-8 7/8
W3	1,825.43	11,446.43	21,056.49	3,397.71	2,133.57	13,330.46	27.82	1-9 1/4
W4	4,737.42	28,975.83	21,056.49	3,397.71	10,567.13	1,701.97	30.49	3-5 3/4
W5	4,737.42	28,975.83	33,502.73	5,541.26	1,021.18	6,948.74	30.49	5-5 3/4
W6	5,809.20	34,814.00	33,502.73	5,541.26	5,153.69	792.48	30.49	7-5 3/4

* Symmetrical Joist

Standard Verticals

Member	Position	Max Tension	Max Comp.	Length
V2	Interior	435.43	3,462.12	18.80

STRESS ANALYSIS - PAGE 2



Job Number: 8010-0704	Job Name: 10-123 BARRHAVEN FIRE STATION - SHOPORDERS	Date Run: 11/19/2010 4:00:33 PM
Location: OTTAWA, ON	Joist Description: Short Span Crimp 20K630/288	Mark: TJ18

Chord Properties

Chord	Area	Rx	Rz	Ryy	Y	Ix	Q	Material
TC	0.7155	0.6489	0.3818	1.3483	0.6194	0.3013	1.0000	A36 = 2.0938 x .187
BC	0.6208	0.6001	0.3508	1.2870	0.5761	0.2235	1.0000	A34 = 1.9375 x .176

Axial and Bending Analysis

K: 1.00	Fy: 50,000.00	Fb: 45,000.00	Mom of Inertia: 235.60	LL 300: 1,634.80	TL 480: 1,021.75	Max Bridg TC: 16-3 1/2	Max Bridg BC: 23-2 1/2
-------------------	-------------------------	-------------------------	----------------------------------	----------------------------	----------------------------	----------------------------------	----------------------------------

Top Chord Check	End Panel LE	First Panel LE	Interior Panel	First Panel RE	End Panel RE	
Length	18.88	20.88	24.00	20.88	18.88	Gap Between Chords: 1.1250
Bending Load	861.61	918.97	1,191.51	1,394.78	1,452.14	Min Weld Len 2X: 0.5000
Axial Load	9,931.77	9,901.26	34,814.00	11,446.43	11,494.55	Max Load Fillers TC: 54,908.25
fa	6,940.37	6,919.05	24,328.19	7,998.82	8,032.45	Max Load no Fillers TC: 45,544.83
Maximum K L/r	49.44	54.68	62.86	54.68	49.44	TC OAL/Ryy: 165.7665
Fcr	41,817.49	40,182.69	37,453.21	40,182.69	41,817.49	BC Stress: 31,248.39
Fa	37,635.74	36,164.42	33,707.89	36,164.42	37,635.74	BC L/Rz: 136.8117
F'e	338,280.72	276,565.63	209,232.27	276,565.63	338,280.72	TC Shear Stress: 19,781.07
Cm	0.9932	0.9917	0.9483	0.9904	0.9921	BC Shear Stress: 23,110.19
Panel Point Moment	3505.47	3675.42	5466.02	5216.01	5417.91	
Mid Panel Moment	2600.94	1685.67	2973.64	2252.66	3940.54	
Panel Point fb	8577.50	8993.36	13374.76	12763.00	13257.03	
Mid Panel fb	2673.48	1732.68	3056.57	2315.48	4050.44	
Fillers	0	0	0	0	0	
Panel Point Stress	15,517.87	15,912.41	37,702.95	20,761.82	21,289.48	
Mid Panel Stress	0.1526	0.1349	0.7875	0.2680	0.2950	

Web Design

Member	Web Tension	Allow Tension	Web Comp	Allow Comp	Weld	Qty	Material
W2	16,507.37	19,546.97	2,561.54	13,054.88	4.94 x 0.150	1	C28 = 1.125 x 1.347 x .150
W3	2,133.57	25,317.00	13,330.46	14,147.43	3.67 x 0.163	1	C32 = 1.125 x 1.479 x .163
W4	10,567.13	11,869.06	1,701.97	6,302.35	4.52 x 0.105	1	C16 = 1.125 x 0.943 x .105
W5	1,021.18	13,593.73	6,948.74	7,629.28	2.71 x 0.115	1	C18 = 1.125 x 1.012 x .115
W6	5,153.69	7,215.59	792.48	2,383.82	3.02 x 0.077	1	C10 = 1.125 x 0.700 x 0.07
V1	347.78	7,215.59	3,158.37	4,571.16	2.00 x 0.077	1	C10 = 1.125 x 0.700 x 0.07
V2	435.43	7,215.59	3,462.12	4,571.89	2.00 x 0.077	1	C10 = 1.125 x 0.700 x 0.07

* Symmetrical Joist

STRESS ANALYSIS - PAGE 3



NEW MILLENNIUM
BUILDING SYSTEMS

<i>Job Number:</i> 8010-0704	<i>Job Name:</i> 10-123 BARRHAVEN FIRE STATION - SHOPORDERS	<i>Date Run:</i> 11/19/2010 4:00:33 PM
<i>Location:</i> OTTAWA, ON	<i>Joist Description:</i> Short Span Crimp 20K630/288	<i>Mark:</i> TJ18

TCX Design

TCX Left		TCX Right	
TCX Length	0-0	TCX Length	0-1 1/2
TCX Type	R	TCX Type	R
TCX Depth	4	TCX Depth	4
BPL Length	0-4	BPL Length	0-5 1/2
Clear Bearing	0-4 7/8	Clear Bearing	0-5 3/8
BPL Material: 69L = 2 x 3 x .250		BPL Material: 69L = 2 x 3 x .250	

Total Load	630.00	Total Load	630.00
Reqd TL Def L/80	0.00	Reqd TL Def L/80	0.02
Live Load	432.00	Live Load	432.00
Reqd LL Def L/120	0.00	Reqd LL Def L/120	0.01
Section Modulus	0.0000	Section Modulus	0.4087
Reqd SM	0.0000	Reqd SM	0.0014
Mom of Inertia	0.0000	Mom of Inertia	0.6026
Reqd MI	0.0000	Reqd MI	0.0000

Seat Type: Lapped

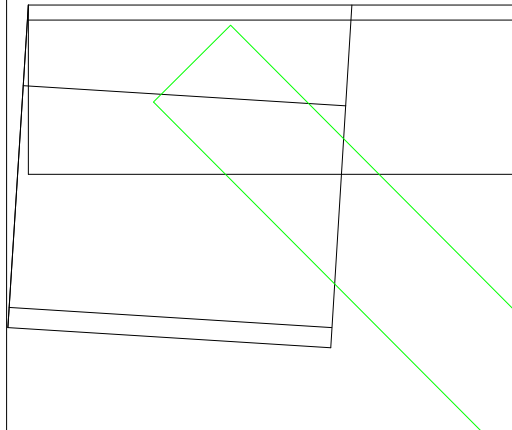

Seat Type: Lapped

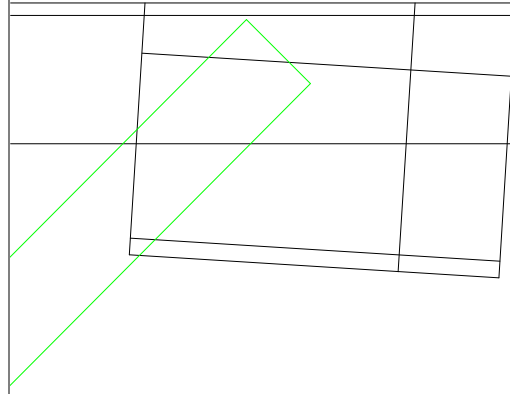

LSD Design

- | | |
|--|--|
| Case 1a: DL | Case 6a: 1.25(DL)+0.5(CL+SL)+1.4(WL+AX)+0.8(TL) |
| Case 1b: 1.4(DL) | Case 6b: 1.25(DL)+0.5(CL+SL)+1.4(WL-AX)+0.8(TL) |
| Case 2a: LL | Case 6c: 1.25(DL)+0.5(CL+SL)+1.4(WL+AX+IP)+0.8(TL) |
| Case 2b: SL | Case 6d: 1.25(DL)+0.5(CL+SL)+1.4(WL-AX+IP)+0.8(TL) |
| Case 3a: 1.25(DL+CL)+1.5(TL+LL) | Case 7a: 1.25(DL+CL)+0.4(WL+AX)+1.5(TL+LL) |
| Case 3b: 1.25(DL+CL)+1.5(TL+SL) | Case 7b: 1.25(DL+CL)+0.4(WL-AX)+1.5(TL+LL) |
| Case 3c: 1.25(DL+CL)+1.5(TL+LL+FEM) | Case 7c: 1.25(DL+CL)+0.4(WL+AX+IP)+1.5(TL+LL) |
| Case 3d: 1.25(DL+CL)+1.5(TL+SL+FEM) | Case 7d: 1.25(DL+CL)+0.4(WL-AX+IP)+1.5(TL+LL) |
| Case 3e: DL+CL+TL+LL | Case 8a: 1.25(DL+CL)+0.4(WL+AX)+1.5(TL+SL) |
| Case 3f: DL+CL+TL+SL | Case 8b: 1.25(DL+CL)+0.4(WL-AX)+1.5(TL+SL) |
| Case 4a: 1.25(DL)+0.5(CL+LL)+1.4(WL+AX)+0.8(TL) | Case 8c: 1.25(DL+CL)+0.4(WL+AX+IP)+1.5(TL+SL) |
| Case 4b: 1.25(DL)+0.5(CL+LL)+1.4(WL-AX)+0.8(TL) | Case 8d: 1.25(DL+CL)+0.4(WL-AX+IP)+1.5(TL+SL) |
| Case 4c: 1.25(DL)+0.5(CL+LL)+1.4(WL+AX+IP)+0.8(TL) | Case 9a: DL+CL+0.5(LL)+0.7(TL)+SM+AX+FEM |
| Case 4d: 1.25(DL)+0.5(CL+LL)+1.4(WL-AX+IP)+0.8(TL) | Case 9b: DL+CL+0.5(LL)+0.7(TL)+SM-AX+FEM |
| Case 4e: 1.25(DL+CL)+1.4(WL+AX)+1.1(TL)+LL | Case 9c: DL+CL+0.25(SL)+0.7(TL)+SM+AX+FEM |
| Case 4f: 1.25(DL+CL)+1.4(WL-AX)+1.1(TL)+LL | Case 9d: DL+CL+0.25(SL)+0.7(TL)+SM-AX+FEM |
| Case 5a: 0.9(DL)+1.4(WL+AX) | Case 9e: DL+CL+LL+1.1(TL)+SM+AX+FEM |
| Case 5b: 0.9(DL)+1.4(WL-AX) | Case 9f: DL+CL+LL+1.1(TL)+SM-AX+FEM |
| Case 5c: 0.9(DL)+1.4(WL+AX+IP) | Case 10a: DL+SM+AX |
| Case 5d: 0.9(DL)+1.4(WL-AX+IP) | Case 10b: DL+SM-AX |
| Case 5e: DL+SM+AX | Case 10c: DL+CL+SM+AX |
| Case 5f: DL+SM-AX | Case 10d: DL+CL+SM-AX |

STRESS ANALYSIS - PAGE 1



NEW MILLENNIUM
BUILDING SYSTEMS

Job Number: 8010-0704	Job Name: 10-123 BARRHAVEN FIRE STATION - SHOPORDERS	Date Run: 11/19/2010 4:00:45 PM
Location: OTTAWA, ON	Joist Description: Short Span Crimp 20K577/263	Mark: TJ19

Geometry

Base Length: 18-3 3/8	Working Length: 17-11 3/8	Joist Depth: 20.00	Effective Depth: 18.93	BC Panel Length: 4 @ 4-0	Shape: Parallel Chords
---------------------------------	-------------------------------------	------------------------------	----------------------------------	------------------------------------	----------------------------------

Variable	Left End	Right End
BC Panel	1-8 3/4	1-8 3/4
TC Panel	1-6 7/8	1-6 7/8
First Half	1-5	1-4 7/8
First Diag.	3-1 3/4	3-1 5/8
Depth	20.00	20.00

Deflection Case 2a: LL (Max Deflection: -0.36 in-Y, -0.07 in-X)

Loads, *** All loads are factored ***

Load Type	Category	Load1	Load2	Position	Direction	Loc/Begin	Sp/End
Uniform (plf)	DL	181.50	181.50	TC	+	0-0	18-3 3/8
Uniform (plf)	LL	394.50	394.50	TC	+	0-0	18-3 3/8
Uniform (plf)	LL	238.00	883.00	TC	+	<0-2 1/4>	18-7 1/8
Net Uplift (plf)	WL	204.00	204.00	TC	-	0-0	18-3 3/8
Conc Load (lbs)	TL	1,700.00	0.00	TC	+	1-9 3/4	7-9 3/4
Conc anywhere (lbs)	TL	315.00	0.00	BC	+	9-1 3/4	0-0
Conc anywhere (lbs)	TL	315.00	0.00	TC	+	9-1 3/4	0-0

Stress Analysis Summary

Int. Panel TC: 24.00	Max Panel BC: 48.00	Reaction LE: 11,373.04	Reaction RE: 12,501.57	Minimum Shear: 3,125.39	Max TC Comp.: 34,912.74	Max BC Tension: 32,729.27
--------------------------------	-------------------------------	----------------------------------	----------------------------------	-----------------------------------	-----------------------------------	-------------------------------------

Member	TC Tension	TC Compression	BC Tension	BC Compression	Web Tension	Web Comp.	Web Length	PP Dist.
W2	1,715.49	11,082.46	0.00	0.00	16,163.14	2,437.98	26.65	0-2
V1S	1,684.70	10,875.63	0.00	0.00	313.51	3,581.38	19.03	1-6 7/8
W3	1,684.70	10,875.63	18,988.32	2,959.85	1,908.80	12,457.39	25.45	1-8 3/4
W4	4,285.92	27,481.87	18,988.32	2,959.85	12,289.31	1,692.56	30.57	3-1 3/4
W5	4,285.92	27,481.87	32,729.27	5,081.01	1,060.53	8,247.02	30.57	5-1 3/4
W6	5,345.12	34,912.74	32,729.27	5,081.01	5,046.12	1,332.81	30.57	7-1 3/4

* Symmetrical Joist

Standard Verticals

Member	Position	Max Tension	Max Comp.	Length
V2	Interior	2,161.36	4,490.44	18.93

STRESS ANALYSIS - PAGE 2



NEW MILLENNIUM
BUILDING SYSTEMS

Job Number: 8010-0704	Job Name: 10-123 BARRHAVEN FIRE STATION - SHOPORDERS	Date Run: 11/19/2010 4:00:45 PM
Location: OTTAWA, ON		Joist Description: Short Span Crimp 20K577/263
		Mark: TJ19

Chord Properties

Chord	Area	Rx	Rz	Ryy	Y	Ix	Q	Material
TC	0.6208	0.6001	0.3508	1.2870	0.5761	0.2235	1.0000	A34 = 1.9375 x .176
BC	0.4801	0.5431	0.3457	1.1847	0.4904	0.1416	0.9538	14 = 1 3/4 x 1 3/4 x .143

Axial and Bending Analysis

K: 1.00	Fy: 50,000.00	Fb: 45,000.00	Mom of Inertia: 194.45	LL 300: 1,507.82	TL 480: 942.39	Max Bridg TC: 15-6 5/8	Max Bridg BC: 19-1
-------------------	-------------------------	-------------------------	----------------------------------	----------------------------	--------------------------	----------------------------------	------------------------------

Top Chord Check	End Panel LE	First Panel LE	Interior Panel	First Panel RE	End Panel RE	Gap Between Chords: 1.1250
Length	16.88	18.88	24.00	18.75	16.88	Min Weld Len 2X: 0.5000
Bending Load	807.30	860.83	1,140.66	1,348.42	1,401.76	Max Load Fillers TC: 45,934.63
Axial Load	9,842.32	9,714.57	34,912.74	10,875.63	11,082.46	Max Load no Fillers TC: 36,794.34
fa	7,927.51	7,824.61	28,120.50	8,759.78	8,926.38	TC OAL/Ryy: 167.3411
Maximum K L/r	48.10	53.80	68.41	53.44	48.10	BC Stress: 40,316.44
Fcr	42,219.13	40,463.59	35,512.37	40,576.79	42,219.13	BC L/Rz: 138.8426
Fa	37,997.21	36,417.23	31,961.13	36,519.11	37,997.21	TC Shear Stress: 22,977.83
F'e	361,899.47	289,268.81	178,917.59	293,138.56	361,899.47	BC Shear Stress: 23,698.34
Cm	0.9927	0.9910	0.9301	0.9900	0.9918	
Panel Point Moment	2655.86	2849.33	5262.62	4039.61	4112.57	
Mid Panel Moment	2070.48	1312.58	2871.94	1680.08	3180.69	
Panel Point fb	8088.21	8677.40	16026.87	12302.29	12524.48	
Mid Panel fb	2668.28	1691.56	3701.14	2165.17	4099.03	
Fillers	0	0	0	0	0	
Panel Point Stress	16,015.72	16,502.00	44,147.37	21,062.07	21,450.86	
Mid Panel Stress	0.2623	0.2490	0.9622	0.2837	0.3175	

Web Design

Member	Web Tension	Allow Tension	Web Comp	Allow Comp	Weld	Qty	Material
W2	16,163.14	19,546.97	2,437.98	13,023.98	4.84 x 0.150	1	C28 = 1.125 x 1.347 x .150
W3	1,908.80	21,718.85	12,457.39	12,712.09	3.73 x 0.150	1	C28 = 1.125 x 1.347 x .150
W4	12,289.31	13,593.73	1,692.56	7,555.70	4.80 x 0.115	1	C18 = 1.125 x 1.012 x .115
W5	1,060.53	16,459.83	8,247.02	9,429.84	2.76 x 0.134	1	C22 = 1.125 x 1.086 x .134
W6	5,046.12	7,215.59	1,332.81	2,303.80	2.95 x 0.077	1	C10 = 1.125 x 0.700 x 0.07
V1	313.51	7,215.59	3,581.38	4,474.84	2.10 x 0.077	1	C10 = 1.125 x 0.700 x 0.07
V2	2,161.36	7,215.59	4,490.44	4,493.16	2.63 x 0.077	1	C10 = 1.125 x 0.700 x 0.07

* Symmetrical Joist

STRESS ANALYSIS - PAGE 3



NEW MILLENNIUM
BUILDING SYSTEMS

Job Number: 8010-0704	Job Name: 10-123 BARRHAVEN FIRE STATION - SHOPORDERS	Date Run: 11/19/2010 4:00:45 PM
Location: OTTAWA, ON	Joist Description: Short Span Crimp 20K577/263	Mark: TJ19

TCX Design

TCX Left		TCX Right	
TCX Length	0-2 1/4	TCX Length	0-0
TCX Type	R	TCX Type	R
TCX Depth	4	TCX Depth	4
BPL Length	0-6 1/4	BPL Length	0-4
Clear Bearing	0-7	Clear Bearing	0-4 3/8
BPL Material: 69L = 2 x 3 x .250		BPL Material: 69L = 2 x 3 x .250	
Total Load	576.00	Total Load	576.00
Reqd TL Def L/80	0.03	Reqd TL Def L/80	0.00
Live Load	394.50	Live Load	394.50
Reqd LL Def L/120	0.02	Reqd LL Def L/120	0.00
Section Modulus	0.3284	Section Modulus	0.0000
Reqd SM	0.0029	Reqd SM	0.0000
Mom of Inertia	0.4470	Mom of Inertia	0.0000
Reqd MI	0.0001	Reqd MI	0.0000
Seat Type: Lapped		Seat Type: Lapped	

LSD Design

- | | |
|--|--|
| Case 1a: DL | Case 6a: 1.25(DL)+0.5(CL+SL)+1.4(WL+AX)+0.8(TL) |
| Case 1b: 1.4(DL) | Case 6b: 1.25(DL)+0.5(CL+SL)+1.4(WL-AX)+0.8(TL) |
| Case 2a: LL | Case 6c: 1.25(DL)+0.5(CL+SL)+1.4(WL+AX+IP)+0.8(TL) |
| Case 2b: SL | Case 6d: 1.25(DL)+0.5(CL+SL)+1.4(WL-AX+IP)+0.8(TL) |
| Case 3a: 1.25(DL+CL)+1.5(TL+LL) | Case 7a: 1.25(DL+CL)+0.4(WL+AX)+1.5(TL+LL) |
| Case 3b: 1.25(DL+CL)+1.5(TL+SL) | Case 7b: 1.25(DL+CL)+0.4(WL-AX)+1.5(TL+LL) |
| Case 3c: 1.25(DL+CL)+1.5(TL+LL+FEM) | Case 7c: 1.25(DL+CL)+0.4(WL+AX+IP)+1.5(TL+LL) |
| Case 3d: 1.25(DL+CL)+1.5(TL+SL+FEM) | Case 7d: 1.25(DL+CL)+0.4(WL-AX+IP)+1.5(TL+LL) |
| Case 3e: DL+CL+TL+LL | Case 8a: 1.25(DL+CL)+0.4(WL+AX)+1.5(TL+SL) |
| Case 3f: DL+CL+TL+SL | Case 8b: 1.25(DL+CL)+0.4(WL-AX)+1.5(TL+SL) |
| Case 4a: 1.25(DL)+0.5(CL+LL)+1.4(WL+AX)+0.8(TL) | Case 8c: 1.25(DL+CL)+0.4(WL+AX+IP)+1.5(TL+SL) |
| Case 4b: 1.25(DL)+0.5(CL+LL)+1.4(WL-AX)+0.8(TL) | Case 8d: 1.25(DL+CL)+0.4(WL-AX+IP)+1.5(TL+SL) |
| Case 4c: 1.25(DL)+0.5(CL+LL)+1.4(WL+AX+IP)+0.8(TL) | Case 9a: DL+CL+0.5(LL)+0.7(TL)+SM+AX+FEM |
| Case 4d: 1.25(DL)+0.5(CL+LL)+1.4(WL-AX+IP)+0.8(TL) | Case 9b: DL+CL+0.5(LL)+0.7(TL)+SM-AX+FEM |
| Case 4e: 1.25(DL+CL)+1.4(WL+AX)+1.1(TL)+LL | Case 9c: DL+CL+0.25(SL)+0.7(TL)+SM+AX+FEM |
| Case 4f: 1.25(DL+CL)+1.4(WL-AX)+1.1(TL)+LL | Case 9d: DL+CL+0.25(SL)+0.7(TL)+SM-AX+FEM |
| Case 5a: 0.9(DL)+1.4(WL+AX) | Case 9e: DL+CL+LL+1.1(TL)+SM+AX+FEM |
| Case 5b: 0.9(DL)+1.4(WL-AX) | Case 9f: DL+CL+LL+1.1(TL)+SM-AX+FEM |
| Case 5c: 0.9(DL)+1.4(WL+AX+IP) | Case 10a: DL+SM+AX |
| Case 5d: 0.9(DL)+1.4(WL-AX+IP) | Case 10b: DL+SM-AX |
| Case 5e: DL+SM+AX | Case 10c: DL+CL+SM+AX |
| Case 5f: DL+SM-AX | Case 10d: DL+CL+SM-AX |

STRESS ANALYSIS - PAGE 1



NEW MILLENNIUM
BUILDING SYSTEMS

Job Number: 8010-0704	Job Name: 10-123 BARRHAVEN FIRE STATION - SHOPORDERS	Date Run: 11/19/2010 4:00:55 PM
Location: OTTAWA, ON	Joist Description: Short Span Crimp 20K577/263	Mark: TJ22

Geometry

Base Length: 18-3 3/8	Working Length: 17-11 3/8	Joist Depth: 20.00	Effective Depth: 18.86	BC Panel Length: 4 @ 4-0	Shape: Parallel Chords
---------------------------------	-------------------------------------	------------------------------	----------------------------------	------------------------------------	----------------------------------

Variable	Left End	Right End
BC Panel	1-8 3/4	1-8 3/4
TC Panel	1-6 7/8	1-6 7/8
First Half	1-5	1-4 7/8
First Diag.	3-1 3/4	3-1 5/8
Depth	20.00	20.00

Deflection Case 2a: LL (Max Deflection: -0.33 in-Y, -0.04 in-X)

Loads, *** All loads are factored ***

Load Type	Category	Load1	Load2	Position	Direction	Loc/Begin	Sp/End
Uniform (plf)	DL	181.50	181.50	TC	+	0-0	18-3 3/8
Uniform (plf)	LL	394.50	394.50	TC	+	0-0	18-3 3/8
Uniform (plf)	LL	238.00	883.00	TC	+	<0-2 1/4>	18-7 1/8
Axial (lbs)	WL	45,000.00	0.00	TC	+	0-0	0-0
Net Uplift (plf)	WL	204.00	204.00	TC	-	0-0	18-3 3/8
Conc anywhere (lbs)	TL	315.00	0.00	BC	+	9-1 3/4	0-0
Conc anywhere (lbs)	TL	315.00	0.00	TC	+	9-1 3/4	0-0

Stress Analysis Summary

Int. Panel TC: 24.00	Max Panel BC: 48.00	Reaction LE: 9,841.59	Reaction RE: 11,789.96	Minimum Shear: 2,947.49	Max TC Comp.: 67,275.20	Max BC Tension: 29,638.54
--------------------------------	-------------------------------	---------------------------------	----------------------------------	-----------------------------------	-----------------------------------	-------------------------------------

Member	TC Tension	TC Compression	BC Tension	BC Compression	Web Tension	Web Comp.	Web Length	PP Dist.
W2	46,721.76	52,453.65	0.00	0.00	15,189.10	2,442.39	26.60	0-2
V1S	46,690.86	52,306.33	0.00	0.00	313.52	3,015.62	18.96	1-6 7/8
W3	46,690.86	52,306.33	17,690.08	2,970.67	1,911.92	11,522.80	25.39	1-8 3/4
W4	49,301.58	63,169.53	17,690.08	2,970.67	10,068.06	1,696.38	30.53	3-1 3/4
W5	49,301.58	63,169.53	29,638.54	5,099.58	1,018.53	6,627.98	30.53	5-1 3/4
W6	50,364.65	67,275.20	29,638.54	5,099.58	4,769.61	760.37	30.53	7-1 3/4

* Symmetrical Joist

Standard Verticals

Member	Position	Max Tension	Max Comp.	Length
V2	Interior	461.36	3,527.25	18.86

STRESS ANALYSIS - PAGE 2



NEW MILLENNIUM
BUILDING SYSTEMS

Job Number: 8010-0704	Job Name: 10-123 BARRHAVEN FIRE STATION - SHOPORDERS	Date Run: 11/19/2010 4:00:55 PM
Location: OTTAWA, ON		Joist Description: Short Span Crimp 20K577/263
		Mark: TJ22

Chord Properties

Chord	Area	Rx	Rz	Ryy	Y	Ix	Q	Material
TC	1.0151	0.7748	0.4934	1.4841	0.7033	0.6093	0.9679	25 = 2 1/2 x 2 1/2 x .212
BC	0.4410	0.4610	0.2946	1.0962	0.4321	0.0937	1.0000	12 = 1 1/2 x 1 1/2 x .155

Axial and Bending Analysis

K: 1.00	Fy: 50,000.00	Fb: 45,000.00	Mom of Inertia: 219.51	LL 300: 1,702.12	TL 480: 1,063.83	Max Bridg TC: 17-11 1/4	Max Bridg BC: 16-6
-------------------	-------------------------	-------------------------	----------------------------------	----------------------------	----------------------------	-----------------------------------	------------------------------

Top Chord Check	End Panel LE	First Panel LE	Interior Panel	First Panel RE	End Panel RE	
Length	16.88	18.88	24.00	18.75	16.88	Gap Between Chords: 1.1250
Bending Load	807.30	860.83	1,140.66	1,348.42	1,401.76	Min Weld Len 2X: 0.5000
Axial Load	51,457.16	51,362.73	67,275.20	52,306.33	52,453.65	Max Load Fillers TC: 80,809.30
fa	25,346.96	25,300.44	33,138.66	25,765.24	25,837.81	Max Load no Fillers TC: 73,183.34
Maximum K L/r	34.20	38.25	48.64	38.00	34.20	TC OAL/Ryy: 145.1202
Fcr	44,549.04	43,632.80	40,933.28	43,692.48	44,549.04	BC Stress: 41,582.00
Fa	40,094.14	39,269.52	36,839.95	39,323.23	40,094.14	BC L/Rz: 162.9103
F'e	603,342.19	482,255.66	298,283.19	488,707.16	603,342.19	TC Shear Stress: 10,499.78
Cm	0.9860	0.9825	0.9506	0.9824	0.9857	BC Shear Stress: 23,949.79
Panel Point Moment	2655.86	2849.33	5262.62	4039.61	4112.57	
Mid Panel Moment	2070.48	1312.58	2871.94	1680.08	3180.69	
Panel Point fb	3915.63	4200.86	7758.86	5955.73	6063.29	
Mid Panel fb	1194.96	757.55	1657.52	969.65	1835.71	
Fillers	0	0	0	0	0	
Panel Point Stress	29,262.58	29,501.30	40,897.52	31,720.98	31,901.11	
Mid Panel Stress	0.6574	0.6604	0.9362	0.6759	0.6832	

Web Design

Member	Web Tension	Allow Tension	Web Comp	Allow Comp	Weld	Qty	Material
W2	15,189.10	19,546.97	2,442.39	13,141.00	4.55 x 0.150	1	C28 = 1.125 x 1.347 x .150
W3	1,911.92	21,718.85	11,522.80	12,807.82	3.45 x 0.150	1	C28 = 1.125 x 1.347 x .150
W4	10,068.06	11,869.06	1,696.38	6,302.48	4.30 x 0.105	1	C16 = 1.125 x 0.943 x .105
W5	1,018.53	13,593.73	6,627.98	7,629.36	2.59 x 0.115	1	C18 = 1.125 x 1.012 x .115
W6	4,769.61	7,215.59	760.37	2,383.91	2.79 x 0.077	1	C10 = 1.125 x 0.700 x 0.07
V1	313.52	7,215.59	3,015.62	4,546.71	2.00 x 0.077	1	C10 = 1.125 x 0.700 x 0.07
V2	461.36	7,215.59	3,527.25	4,564.75	2.00 x 0.077	1	C10 = 1.125 x 0.700 x 0.07

* Symmetrical Joist

STRESS ANALYSIS - PAGE 3



NEW MILLENNIUM
BUILDING SYSTEMS

Job Number: 8010-0704	Job Name: 10-123 BARRHAVEN FIRE STATION - SHOPORDERS	Date Run: 11/19/2010 4:00:55 PM
Location: OTTAWA, ON	Joist Description: Short Span Crimp 20K577/263	Mark: TJ22

TCX Design

TCX Left		TCX Right	
TCX Length	0-2 1/4	TCX Length	0-0
TCX Type	R	TCX Type	R
TCX Depth	4	TCX Depth	4
BPL Length	0-6 1/4	BPL Length	0-4
Clear Bearing	0-6 1/2	Clear Bearing	0-4 1/4
BPL Material: 69L = 2 x 3 x .250		BPL Material: 69L = 2 x 3 x .250	
Total Load	576.00	Total Load	576.00
Reqd TL Def L/80	0.03	Reqd TL Def L/80	0.00
Live Load	394.50	Live Load	394.50
Reqd LL Def L/120	0.02	Reqd LL Def L/120	0.00
Section Modulus	0.6783	Section Modulus	0.0000
Reqd SM	0.0029	Reqd SM	0.0000
Mom of Inertia	1.2186	Mom of Inertia	0.0000
Reqd MI	0.0001	Reqd MI	0.0000
Seat Type: Lapped		Seat Type: Lapped	

LSD Design

- | | |
|--|--|
| Case 1a: DL | Case 6a: 1.25(DL)+0.5(CL+SL)+1.4(WL+AX)+0.8(TL) |
| Case 1b: 1.4(DL) | Case 6b: 1.25(DL)+0.5(CL+SL)+1.4(WL-AX)+0.8(TL) |
| Case 2a: LL | Case 6c: 1.25(DL)+0.5(CL+SL)+1.4(WL+AX+IP)+0.8(TL) |
| Case 2b: SL | Case 6d: 1.25(DL)+0.5(CL+SL)+1.4(WL-AX+IP)+0.8(TL) |
| Case 3a: 1.25(DL+CL)+1.5(TL+LL) | Case 7a: 1.25(DL+CL)+0.4(WL+AX)+1.5(TL+LL) |
| Case 3b: 1.25(DL+CL)+1.5(TL+SL) | Case 7b: 1.25(DL+CL)+0.4(WL-AX)+1.5(TL+LL) |
| Case 3c: 1.25(DL+CL)+1.5(TL+LL+FEM) | Case 7c: 1.25(DL+CL)+0.4(WL+AX+IP)+1.5(TL+LL) |
| Case 3d: 1.25(DL+CL)+1.5(TL+SL+FEM) | Case 7d: 1.25(DL+CL)+0.4(WL-AX+IP)+1.5(TL+LL) |
| Case 3e: DL+CL+TL+LL | Case 8a: 1.25(DL+CL)+0.4(WL+AX)+1.5(TL+SL) |
| Case 3f: DL+CL+TL+SL | Case 8b: 1.25(DL+CL)+0.4(WL-AX)+1.5(TL+SL) |
| Case 4a: 1.25(DL)+0.5(CL+LL)+1.4(WL+AX)+0.8(TL) | Case 8c: 1.25(DL+CL)+0.4(WL+AX+IP)+1.5(TL+SL) |
| Case 4b: 1.25(DL)+0.5(CL+LL)+1.4(WL-AX)+0.8(TL) | Case 8d: 1.25(DL+CL)+0.4(WL-AX+IP)+1.5(TL+SL) |
| Case 4c: 1.25(DL)+0.5(CL+LL)+1.4(WL+AX+IP)+0.8(TL) | Case 9a: DL+CL+0.5(LL)+0.7(TL)+SM+AX+FEM |
| Case 4d: 1.25(DL)+0.5(CL+LL)+1.4(WL-AX+IP)+0.8(TL) | Case 9b: DL+CL+0.5(LL)+0.7(TL)+SM-AX+FEM |
| Case 4e: 1.25(DL+CL)+1.4(WL+AX)+1.1(TL)+LL | Case 9c: DL+CL+0.25(SL)+0.7(TL)+SM+AX+FEM |
| Case 4f: 1.25(DL+CL)+1.4(WL-AX)+1.1(TL)+LL | Case 9d: DL+CL+0.25(SL)+0.7(TL)+SM-AX+FEM |
| Case 5a: 0.9(DL)+1.4(WL+AX) | Case 9e: DL+CL+LL+1.1(TL)+SM+AX+FEM |
| Case 5b: 0.9(DL)+1.4(WL-AX) | Case 9f: DL+CL+LL+1.1(TL)+SM-AX+FEM |
| Case 5c: 0.9(DL)+1.4(WL+AX+IP) | Case 10a: DL+SM+AX |
| Case 5d: 0.9(DL)+1.4(WL-AX+IP) | Case 10b: DL+SM-AX |
| Case 5e: DL+SM+AX | Case 10c: DL+CL+SM+AX |
| Case 5f: DL+SM-AX | Case 10d: DL+CL+SM-AX |

STRESS ANALYSIS - PAGE 1



NEW MILLENNIUM
BUILDING SYSTEMS

Job Number: 8010-0704	Job Name: 10-123 BARRHAVEN FIRE STATION - SHOPORDERS	Date Run: 11/19/2010 4:10:27 PM
Location: OTTAWA, ON		Joist Description: Short Span Crimp 22K704/321
		Mark: TJ25

Geometry

Base Length: 26-11 3/4	Working Length: 26-7 3/4	Joist Depth: 22.00	Effective Depth: 21.01	BC Panel Length: 6 @ 4-0	Shape: Double Pitch with Ridge @ 13-5 7/8
----------------------------------	------------------------------------	------------------------------	----------------------------------	------------------------------------	---

Variable	Left End	Right End	Deflection Case 2a: LL (Max Deflection: -0.68 in-Y, -0.13 in-X)
BC Panel	1-11 1/8	1-11 1/8	
TC Panel	1-8 7/8	1-8 7/8	
First Half	1-6 3/4	1-6 3/4	
First Diag.	3-5 7/8	3-5 7/8	
Depth	24.00	24.00	

Loads, *** All loads are factored ***

Load Type	Category	Load1	Load2	Position	Direction	Loc/Begin	Sp/End
Uniform (plf)	DL	222.50	222.50	TC	+	0-0	26-11 3/4
Uniform (plf)	LL	481.50	481.50	TC	+	0-0	26-11 3/4
Net Uplift (plf)	WL	221.00	221.00	TC	-	0-0	26-11 3/4
Conc anywhere (lbs)	TL	315.00	0.00	BC	+	13-5 7/8	0-0
Conc anywhere (lbs)	TL	315.00	0.00	TC	+	13-5 7/8	0-0

Stress Analysis Summary

Int. Panel TC: 24.00	Max Panel BC: 48.00	Reaction LE: 9,997.45	Reaction RE: 10,003.39	Minimum Shear: 2,500.85	Max TC Comp.: 38,076.88	Max BC Tension: 36,396.67
--------------------------------	-------------------------------	---------------------------------	----------------------------------	-----------------------------------	-----------------------------------	-------------------------------------

Member	TC Tension	TC Compression	BC Tension	BC Compression	Web Tension	Web Comp.	Web Length	PP Dist.
W2	2,652.99	8,496.18	0.00	0.00	12,967.65	3,920.73	31.22	0-2
V1S	2,615.54	8,380.38	0.00	0.00	380.58	1,952.85	22.87	1-8 7/8
W3	2,615.54	8,380.38	15,109.26	4,705.81	3,265.19	10,796.86	29.29	1-11 1/8
W4	6,984.31	22,502.73	15,109.26	4,705.81	10,450.71	3,122.32	32.90	3-5 7/8
W5	6,984.31	22,502.73	28,550.19	8,824.50	2,492.13	8,371.55	32.49	5-5 7/8
W6	10,210.78	33,204.06	28,550.19	8,824.50	6,474.83	1,875.80	32.49	7-5 7/8
V3	10,210.78	33,204.06	28,550.19	8,824.50	455.35	2,002.55	21.61	9-5 7/8
W7	10,210.78	33,204.06	36,396.66	11,121.25	1,218.66	4,301.63	32.10	9-5 7/8
W8	11,539.07	38,076.88	36,396.66	11,121.25	3,792.89	1,150.11	32.10	11-5 7/8
V4	11,539.07	38,076.88	36,396.66	11,121.25	740.46	3,109.99	21.01	13-5 7/8
W8	11,539.07	38,076.88	36,396.67	11,121.25	3,792.89	1,150.11	32.10	13-5 7/8
W7	10,210.78	33,204.06	36,396.67	11,121.25	1,218.66	4,310.52	32.10	15-5 7/8
V5	10,210.78	33,204.06	36,396.67	11,121.25	455.35	1,812.35	21.61	17-5 7/8
W6	10,210.78	33,204.06	28,550.19	8,824.50	6,483.71	1,875.80	32.49	17-5 7/8
W5	6,984.31	22,502.72	28,550.19	8,824.50	2,492.13	8,380.31	32.49	19-5 7/8
V6	6,984.31	22,502.72	28,550.19	8,824.50	455.35	1,723.20	22.20	21-5 7/8
W4	6,984.31	22,502.72	15,109.26	4,705.81	10,459.46	3,122.32	32.90	21-5 7/8
W3	2,615.54	8,380.38	15,109.26	4,705.81	3,265.19	10,804.56	29.29	23-5 7/8
V1S	2,615.54	8,380.38	0.00	0.00	380.58	1,958.83	22.87	25-2 7/8
W2	2,652.99	8,496.18	0.00	0.00	12,975.76	3,920.73	31.22	25-0 5/8

Standard Verticals

Member	Position	Max Tension	Max Comp.	Length
V2	Interior	740.46	3,109.99	22.20

STRESS ANALYSIS - PAGE 2



Job Number: 8010-0704	Job Name: 10-123 BARRHAVEN FIRE STATION - SHOPORDERS	Date Run: 11/19/2010 4:10:27 PM
Location: OTTAWA, ON		Joist Description: Short Span Crimp 22K704/321
		Mark: TJ25

Chord Properties

Chord	Area	Rx	Rz	Ryy	Y	Ix	Q	Material
TC	0.5185	0.5414	0.3450	1.1878	0.4947	0.1520	0.9837	15 = 1 3/4 x 1 3/4 x .155
BC	0.4801	0.5431	0.3457	1.1847	0.4904	0.1416	0.9538	14 = 1 3/4 x 1 3/4 x .143

Axial and Bending Analysis

K: 1.00	Fy: 50,000.00	Fb: 45,000.00	Mom of Inertia: 220.45	LL 360: 435.34	LL 240: 653.02	Max Bridg TC: 14-4 1/4	Max Bridg BC: 12-8 7/8
-------------------	-------------------------	-------------------------	----------------------------------	--------------------------	--------------------------	----------------------------------	----------------------------------

Top Chord Check	End Panel LE	First Panel LE	Interior Panel	First Panel RE	End Panel RE	
Length	18.88	21.00	24.00	21.00	18.88	Gap Between Chords: 1.1250
Bending Load	683.12	0.00	0.00	0.00	683.12	Min Weld Len 2X: 0.5000
Axial Load	8,496.18	8,380.38	38,076.88	8,380.38	8,496.18	Max Load Fillers TC: 39,594.69
fa	8,193.43	8,081.76	36,720.08	8,081.76	8,193.43	Max Load no Fillers TC: 32,236.54
Maximum K L/r	54.71	60.87	44.33	60.87	54.71	TC OAL/Ryy: 269.1959
Fcr	39,659.33	37,679.88	42,701.82	37,679.88	39,659.33	BC Stress: 44,136.25
Fa	35,693.40	33,911.89	38,431.64	33,911.89	35,693.40	BC L/Rz: 138.8426
F'e	235,461.86	190,219.88	145,637.08	190,219.88	235,461.86	TC Shear Stress: 17,931.68
Cm	0.9884	0.9858	0.8879	0.9858	0.9884	BC Shear Stress: 19,630.09
Panel Point Moment	2942.87	700.05	700.05	700.05	2942.87	
Mid Panel Moment	2190.47	590.67	590.67	590.67	2190.47	
Panel Point fb	12153.15	2891.00	2891.00	2891.00	12153.15	
Mid Panel fb	3565.18	961.37	961.37	961.37	3565.18	
Fillers	0	0	6	0	0	
Panel Point Stress	20,346.58	10,972.77	39,611.08	10,972.76	20,346.58	
Mid Panel Stress	0.3032	0.2583	0.9793	0.2583	0.3032	

Web Design

Member	Web Tension	Allow Tension	Web Comp	Allow Comp	Weld	Qty	Material
W2	12,967.65	14,813.85	3,920.73	9,258.36	4.34 x 0.134	1	C22 = 1.125 x 1.086 x .134
W3	3,265.19	21,718.85	10,796.86	11,693.75	3.23 x 0.150	1	C28 = 1.125 x 1.347 x .150
W4	10,450.71	11,869.06	3,122.32	5,383.96	4.47 x 0.105	1	C16 = 1.125 x 0.943 x .105
W5	2,492.13	16,459.83	8,371.55	8,926.58	2.80 x 0.134	1	C22 = 1.125 x 1.086 x .134
W6	6,474.83	7,215.59	1,875.80	1,931.68	3.79 x 0.077	1	C10 = 1.125 x 0.700 x 0.07
W7	1,218.66	11,869.06	4,301.63	5,631.54	2.00 x 0.105	1	C16 = 1.125 x 0.943 x .105
W8	3,792.89	7,215.59	1,150.11	1,994.11	2.22 x 0.077	1	C10 = 1.125 x 0.700 x 0.07
W8	3,792.89	7,215.59	1,150.11	1,994.11	2.22 x 0.077	1	C10 = 1.125 x 0.700 x 0.07
W7	1,218.66	11,869.06	4,310.52	5,631.54	2.00 x 0.105	1	C16 = 1.125 x 0.943 x .105
W6	6,483.71	7,215.59	1,875.80	1,931.68	3.80 x 0.077	1	C10 = 1.125 x 0.700 x 0.07
W5	2,492.13	16,459.83	8,380.31	8,926.58	2.81 x 0.134	1	C22 = 1.125 x 1.086 x .134
W4	10,459.46	11,869.06	3,122.32	5,383.96	4.47 x 0.105	1	C16 = 1.125 x 0.943 x .105
W3	3,265.19	21,718.85	10,804.56	11,693.75	3.23 x 0.150	1	C28 = 1.125 x 1.347 x .150
W2	12,975.76	14,813.85	3,920.73	9,258.36	4.35 x 0.134	1	C22 = 1.125 x 1.086 x .134
V1	380.58	7,215.59	1,958.83	3,565.97	2.00 x 0.077	1	C10 = 1.125 x 0.700 x 0.07
V2	740.46	7,215.59	3,109.99	3,715.29	2.00 x 0.077	1	C10 = 1.125 x 0.700 x 0.07

STRESS ANALYSIS - PAGE 3



NEW MILLENNIUM
BUILDING SYSTEMS

Job Number: 8010-0704	Job Name: 10-123 BARRHAVEN FIRE STATION - SHOPORDERS	Date Run: 11/19/2010 4:10:27 PM
Location: OTTAWA, ON	Joist Description: Short Span Crimp 22K704/321	Mark: TJ25

TCX Design

TCX Left		TCX Right	
TCX Length	0-2	TCX Length	0-1 1/2
TCX Type	R	TCX Type	R
TCX Depth	4	TCX Depth	4
BPL Length	0-6	BPL Length	0-5 1/2
Clear Bearing	0-6 3/8	Clear Bearing	0-5 7/8
BPL Material: 69L = 2 x 3 x .250		BPL Material: 69L = 2 x 3 x .250	

Total Load	704.00	Total Load	704.00
Reqd TL Def L/80	0.03	Reqd TL Def L/80	0.02
Live Load	481.50	Live Load	481.50
Reqd LL Def L/120	0.02	Reqd LL Def L/120	0.01
Section Modulus	0.2421	Section Modulus	0.2421
Reqd SM	0.0028	Reqd SM	0.0016
Mom of Inertia	0.3040	Mom of Inertia	0.3040
Reqd MI	0.0001	Reqd MI	0.0000

Seat Type: Lapped

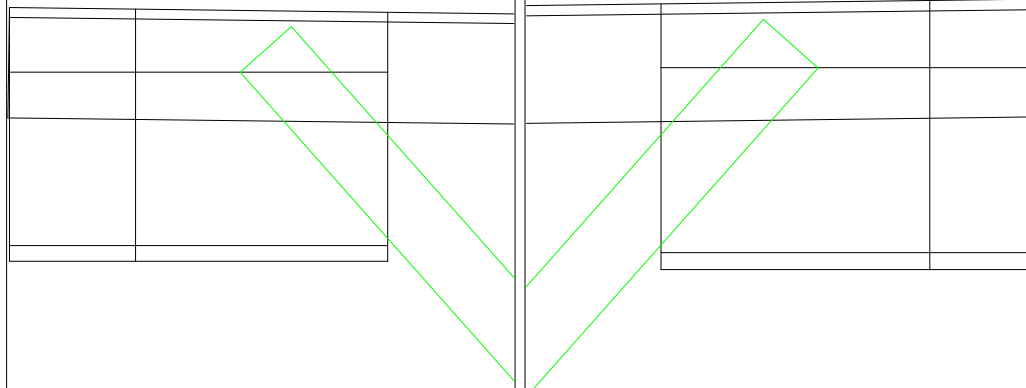

LSD Design

- | | |
|--|--|
| Case 1a: DL | Case 6a: 1.25(DL)+0.5(CL+SL)+1.4(WL+AX)+0.8(TL) |
| Case 1b: 1.4(DL) | Case 6b: 1.25(DL)+0.5(CL+SL)+1.4(WL-AX)+0.8(TL) |
| Case 2a: LL | Case 6c: 1.25(DL)+0.5(CL+SL)+1.4(WL+AX+IP)+0.8(TL) |
| Case 2b: SL | Case 6d: 1.25(DL)+0.5(CL+SL)+1.4(WL-AX+IP)+0.8(TL) |
| Case 3a: 1.25(DL+CL)+1.5(TL+LL) | Case 7a: 1.25(DL+CL)+0.4(WL+AX)+1.5(TL+LL) |
| Case 3b: 1.25(DL+CL)+1.5(TL+SL) | Case 7b: 1.25(DL+CL)+0.4(WL-AX)+1.5(TL+LL) |
| Case 3c: 1.25(DL+CL)+1.5(TL+LL+FEM) | Case 7c: 1.25(DL+CL)+0.4(WL+AX+IP)+1.5(TL+LL) |
| Case 3d: 1.25(DL+CL)+1.5(TL+SL+FEM) | Case 7d: 1.25(DL+CL)+0.4(WL-AX+IP)+1.5(TL+LL) |
| Case 3e: DL+CL+TL+LL | Case 8a: 1.25(DL+CL)+0.4(WL+AX)+1.5(TL+SL) |
| Case 3f: DL+CL+TL+SL | Case 8b: 1.25(DL+CL)+0.4(WL-AX)+1.5(TL+SL) |
| Case 4a: 1.25(DL)+0.5(CL+LL)+1.4(WL+AX)+0.8(TL) | Case 8c: 1.25(DL+CL)+0.4(WL+AX+IP)+1.5(TL+SL) |
| Case 4b: 1.25(DL)+0.5(CL+LL)+1.4(WL-AX)+0.8(TL) | Case 8d: 1.25(DL+CL)+0.4(WL-AX+IP)+1.5(TL+SL) |
| Case 4c: 1.25(DL)+0.5(CL+LL)+1.4(WL+AX+IP)+0.8(TL) | Case 9a: DL+CL+0.5(LL)+0.7(TL)+SM+AX+FEM |
| Case 4d: 1.25(DL)+0.5(CL+LL)+1.4(WL-AX+IP)+0.8(TL) | Case 9b: DL+CL+0.5(LL)+0.7(TL)+SM-AX+FEM |
| Case 4e: 1.25(DL+CL)+1.4(WL+AX)+1.1(TL)+LL | Case 9c: DL+CL+0.25(SL)+0.7(TL)+SM+AX+FEM |
| Case 4f: 1.25(DL+CL)+1.4(WL-AX)+1.1(TL)+LL | Case 9d: DL+CL+0.25(SL)+0.7(TL)+SM-AX+FEM |
| Case 5a: 0.9(DL)+1.4(WL+AX) | Case 9e: DL+CL+LL+1.1(TL)+SM+AX+FEM |
| Case 5b: 0.9(DL)+1.4(WL-AX) | Case 9f: DL+CL+LL+1.1(TL)+SM-AX+FEM |
| Case 5c: 0.9(DL)+1.4(WL+AX+IP) | Case 10a: DL+SM+AX |
| Case 5d: 0.9(DL)+1.4(WL-AX+IP) | Case 10b: DL+SM-AX |
| Case 5e: DL+SM+AX | Case 10c: DL+CL+SM+AX |
| Case 5f: DL+SM-AX | Case 10d: DL+CL+SM-AX |

STRESS ANALYSIS - PAGE 1



NEW MILLENNIUM
BUILDING SYSTEMS

Job Number: 8010-0704	Job Name: 10-123 BARRHAVEN FIRE STATION - SHOPORDERS	Date Run: 11/19/2010 4:11:04 PM
Location: OTTAWA, ON	Joist Description: Short Span Crimp 23K704/321	Mark: TJ27

Geometry

Base Length: 26-11 1/4	Working Length: 26-7 1/4	Joist Depth: 23.00	Effective Depth: 22.01	BC Panel Length: 6 @ 4-0	Shape: Double Pitch with Ridge @ 13-5 5/8
----------------------------------	------------------------------------	------------------------------	----------------------------------	------------------------------------	---

Variable	Left End	Right End
BC Panel	2-0 5/8	2-0 5/8
TC Panel	1-8 3/4	1-8 3/4
First Half	1-5	1-5
First Diag.	3-5 5/8	3-5 5/8
Depth	24.00	24.00

Deflection Case 2a: LL (Max Deflection: -0.63 in-Y, -0.12 in-X)

Loads, *** All loads are factored ***

Load Type	Category	Load1	Load2	Position	Direction	Loc/Begin	Sp/End
Uniform (plf)	DL	222.50	222.50	TC	+	0-0	26-11 1/4
Uniform (plf)	LL	481.50	481.50	TC	+	0-0	26-11 1/4
Net Uplift (plf)	WL	221.00	221.00	TC	-	0-0	26-11 1/4
Conc anywhere (lbs)	TL	315.00	0.00	BC	+	13-5 5/8	0-0
Conc anywhere (lbs)	TL	315.00	0.00	TC	+	13-5 5/8	0-0

Stress Analysis Summary

Int. Panel TC: 24.00	Max Panel BC: 48.00	Reaction LE: 9,982.78	Reaction RE: 9,988.72	Minimum Shear: 2,497.18	Max TC Comp.: 36,235.21	Max BC Tension: 34,888.30
--------------------------------	-------------------------------	---------------------------------	---------------------------------	-----------------------------------	-----------------------------------	-------------------------------------

Member	TC Tension	TC Compression	BC Tension	BC Compression	Web Tension	Web Comp.	Web Length	PP Dist.
W2	2,821.12	9,034.98	0.00	0.00	13,309.30	4,023.01	32.26	0-2
V1S	2,757.40	8,837.97	0.00	0.00	381.65	1,952.34	23.21	1-8 3/4
W3	2,757.40	8,837.97	14,830.33	4,618.78	3,110.34	10,291.09	28.41	2-0 5/8
W4	6,824.40	21,988.40	14,830.33	4,618.78	10,186.70	3,039.36	33.07	3-5 5/8
W5	6,824.40	21,988.40	27,735.74	8,572.36	2,394.19	8,062.01	32.87	5-5 5/8
W6	9,854.11	32,046.10	27,735.74	8,572.36	6,090.62	1,755.22	32.87	7-5 5/8
V3	9,854.11	32,046.10	27,735.74	8,572.36	455.35	1,993.33	22.31	9-5 5/8
W7	9,854.11	32,046.10	34,888.30	10,659.56	1,112.28	3,914.78	32.67	9-5 5/8
W8	10,979.88	36,235.21	34,888.30	10,659.56	3,693.17	1,119.76	32.67	11-5 5/8
V4	10,979.88	36,235.21	34,888.30	10,659.56	591.22	2,639.29	22.01	13-5 5/8
W8	10,979.88	36,235.21	34,888.30	10,659.56	3,693.17	1,119.76	32.67	13-5 5/8
W7	9,854.11	32,046.10	34,888.30	10,659.56	1,112.28	3,923.51	32.67	15-5 5/8
V5	9,854.11	32,046.10	34,888.30	10,659.56	455.35	1,803.14	22.31	17-5 5/8
W6	9,854.11	32,046.10	27,735.74	8,572.36	6,099.35	1,755.22	32.87	17-5 5/8
W5	6,824.40	21,988.40	27,735.74	8,572.36	2,394.19	8,070.68	32.87	19-5 5/8
V6	6,824.40	21,988.40	27,735.74	8,572.36	455.35	1,713.99	22.61	21-5 5/8
W4	6,824.40	21,988.40	14,830.33	4,618.78	10,195.37	3,039.36	33.07	21-5 5/8
W3	2,757.40	8,837.97	14,830.33	4,618.78	3,110.34	10,298.50	28.41	23-5 5/8
V1S	2,757.40	8,837.97	0.00	0.00	381.65	1,958.37	23.21	25-2 1/2
W2	2,821.12	9,034.98	0.00	0.00	13,317.66	4,023.01	32.26	24-10 5/8

Standard Verticals

Member	Position	Max Tension	Max Comp.	Length
V2	Interior	591.22	2,639.29	22.61

STRESS ANALYSIS - PAGE 2



NEW MILLENNIUM
BUILDING SYSTEMS

Job Number: 8010-0704	Job Name: 10-123 BARRHAVEN FIRE STATION - SHOPORDERS	Date Run: 11/19/2010 4:11:04 PM
Location: OTTAWA, ON	Joist Description: Short Span Crimp 23K704/321	Mark: TJ27

Chord Properties

Chord	Area	Rx	Rz	Ryy	Y	Ix	Q	Material
TC	0.5185	0.5414	0.3450	1.1878	0.4947	0.1520	0.9837	15 = 1 3/4 x 1 3/4 x .155
BC	0.4801	0.5431	0.3457	1.1847	0.4904	0.1416	0.9538	14 = 1 3/4 x 1 3/4 x .143

Axial and Bending Analysis

K: 1.00	Fy: 50,000.00	Fb: 45,000.00	Mom of Inertia: 241.91	LL 360: 479.95	LL 240: 719.93	Max Bridg TC: 14-4 1/4	Max Bridg BC: 13-0 3/8
-------------------	-------------------------	-------------------------	----------------------------------	--------------------------	--------------------------	----------------------------------	----------------------------------

Top Chord Check	End Panel LE	First Panel LE	Interior Panel	First Panel RE	End Panel RE	
Length	18.75	20.88	24.00	20.88	18.75	Gap Between Chords: 1.1250
Bending Load	683.16	0.00	0.00	0.00	683.16	Min Weld Len 2X: 0.5000
Axial Load	9,034.98	8,837.97	36,235.21	8,837.97	9,034.98	Max Load Fillers TC: 39,595.42
fa	8,713.04	8,523.05	34,944.03	8,523.04	8,713.03	Max Load no Fillers TC: 32,237.88
Maximum K L/r	54.34	60.50	44.33	60.50	54.34	TC OAL/Ryy: 268.7749
Fcr	39,773.16	37,800.38	42,702.52	37,800.38	39,773.16	BC Stress: 42,565.20
Fa	35,795.85	34,020.34	38,432.27	34,020.34	35,795.85	BC L/Rz: 138.8426
F'e	238,639.09	192,526.81	145,653.73	192,526.81	238,639.09	TC Shear Stress: 17,975.23
Cm	0.9878	0.9852	0.8934	0.9852	0.9878	BC Shear Stress: 19,583.74
Panel Point Moment	2904.88	700.01	700.01	700.01	2904.88	
Mid Panel Moment	2167.12	590.64	590.64	590.64	2167.12	
Panel Point fb	11996.24	2890.84	2890.84	2890.84	11996.24	
Mid Panel fb	3527.18	961.31	961.31	961.31	3527.18	
Fillers	0	0	6	0	0	
Panel Point Stress	20,709.27	11,413.88	37,834.87	11,413.88	20,709.27	
Mid Panel Stress	0.3163	0.2705	0.9327	0.2705	0.3163	

Web Design

Member	Web Tension	Allow Tension	Web Comp	Allow Comp	Weld	Qty	Material
W2	13,309.30	14,813.85	4,023.01	9,054.65	4.46 x 0.134	1	C22 = 1.125 x 1.086 x .134
W3	3,110.34	21,718.85	10,291.09	11,880.33	3.08 x 0.150	1	C28 = 1.125 x 1.347 x .150
W4	10,186.70	11,869.06	3,039.36	5,329.85	4.36 x 0.105	1	C16 = 1.125 x 0.943 x .105
W5	2,394.19	16,459.83	8,062.01	8,837.07	2.70 x 0.134	1	C22 = 1.125 x 1.086 x .134
W6	6,090.62	7,215.59	1,755.22	1,875.53	3.57 x 0.077	1	C10 = 1.125 x 0.700 x 0.07
W7	1,112.28	11,869.06	3,914.78	5,453.61	2.00 x 0.105	1	C16 = 1.125 x 0.943 x .105
W8	3,693.17	7,215.59	1,119.76	1,905.25	2.16 x 0.077	1	C10 = 1.125 x 0.700 x 0.07
W8	3,693.17	7,215.59	1,119.76	1,905.25	2.16 x 0.077	1	C10 = 1.125 x 0.700 x 0.07
W7	1,112.28	11,869.06	3,923.51	5,453.61	2.00 x 0.105	1	C16 = 1.125 x 0.943 x .105
W6	6,099.35	7,215.59	1,755.22	1,875.53	3.57 x 0.077	1	C10 = 1.125 x 0.700 x 0.07
W5	2,394.19	16,459.83	8,070.68	8,837.07	2.70 x 0.134	1	C22 = 1.125 x 1.086 x .134
W4	10,195.37	11,869.06	3,039.36	5,329.85	4.36 x 0.105	1	C16 = 1.125 x 0.943 x .105
W3	3,110.34	21,718.85	10,298.50	11,880.33	3.08 x 0.150	1	C28 = 1.125 x 1.347 x .150
W2	13,317.66	14,813.85	4,023.01	9,054.65	4.46 x 0.134	1	C22 = 1.125 x 1.086 x .134
V1	381.65	7,215.59	1,958.37	3,493.31	2.00 x 0.077	1	C10 = 1.125 x 0.700 x 0.07
V2	591.22	7,215.59	2,639.29	3,622.12	2.00 x 0.077	1	C10 = 1.125 x 0.700 x 0.07

STRESS ANALYSIS - PAGE 3



NEW MILLENNIUM
BUILDING SYSTEMS

<i>Job Number:</i> 8010-0704	<i>Job Name:</i> 10-123 BARRHAVEN FIRE STATION - SHOPORDERS	<i>Date Run:</i> 11/19/2010 4:11:04 PM
<i>Location:</i> OTTAWA, ON	<i>Joist Description:</i> Short Span Crimp 23K704/321	<i>Mark:</i> TJ27

TCX Design

TCX Left		TCX Right	
TCX Length	0-2 1/2	TCX Length	0-1 1/2
TCX Type	R	TCX Type	R
TCX Depth	4	TCX Depth	4
BPL Length	0-6 1/2	BPL Length	0-5 1/2
Clear Bearing	0-7	Clear Bearing	0-6
BPL Material: 69L = 2 x 3 x .250		BPL Material: 69L = 2 x 3 x .250	
Total Load	704.00	Total Load	704.00
Reqd TL Def L/80	0.03	Reqd TL Def L/80	0.02
Live Load	481.50	Live Load	481.50
Reqd LL Def L/120	0.02	Reqd LL Def L/120	0.01
Section Modulus	0.2421	Section Modulus	0.2421
Reqd SM	0.0043	Reqd SM	0.0016
Mom of Inertia	0.3040	Mom of Inertia	0.3040
Reqd MI	0.0002	Reqd MI	0.0000
Seat Type: Lapped		Seat Type: Lapped	

LSD Design

- | | |
|--|--|
| Case 1a: DL | Case 6a: 1.25(DL)+0.5(CL+SL)+1.4(WL+AX)+0.8(TL) |
| Case 1b: 1.4(DL) | Case 6b: 1.25(DL)+0.5(CL+SL)+1.4(WL-AX)+0.8(TL) |
| Case 2a: LL | Case 6c: 1.25(DL)+0.5(CL+SL)+1.4(WL+AX+IP)+0.8(TL) |
| Case 2b: SL | Case 6d: 1.25(DL)+0.5(CL+SL)+1.4(WL-AX+IP)+0.8(TL) |
| Case 3a: 1.25(DL+CL)+1.5(TL+LL) | Case 7a: 1.25(DL+CL)+0.4(WL+AX)+1.5(TL+LL) |
| Case 3b: 1.25(DL+CL)+1.5(TL+SL) | Case 7b: 1.25(DL+CL)+0.4(WL-AX)+1.5(TL+LL) |
| Case 3c: 1.25(DL+CL)+1.5(TL+LL+FEM) | Case 7c: 1.25(DL+CL)+0.4(WL+AX+IP)+1.5(TL+LL) |
| Case 3d: 1.25(DL+CL)+1.5(TL+SL+FEM) | Case 7d: 1.25(DL+CL)+0.4(WL-AX+IP)+1.5(TL+LL) |
| Case 3e: DL+CL+TL+LL | Case 8a: 1.25(DL+CL)+0.4(WL+AX)+1.5(TL+SL) |
| Case 3f: DL+CL+TL+SL | Case 8b: 1.25(DL+CL)+0.4(WL-AX)+1.5(TL+SL) |
| Case 4a: 1.25(DL)+0.5(CL+LL)+1.4(WL+AX)+0.8(TL) | Case 8c: 1.25(DL+CL)+0.4(WL+AX+IP)+1.5(TL+SL) |
| Case 4b: 1.25(DL)+0.5(CL+LL)+1.4(WL-AX)+0.8(TL) | Case 8d: 1.25(DL+CL)+0.4(WL-AX+IP)+1.5(TL+SL) |
| Case 4c: 1.25(DL)+0.5(CL+LL)+1.4(WL+AX+IP)+0.8(TL) | Case 9a: DL+CL+0.5(LL)+0.7(TL)+SM+AX+FEM |
| Case 4d: 1.25(DL)+0.5(CL+LL)+1.4(WL-AX+IP)+0.8(TL) | Case 9b: DL+CL+0.5(LL)+0.7(TL)+SM-AX+FEM |
| Case 4e: 1.25(DL+CL)+1.4(WL+AX)+1.1(TL)+LL | Case 9c: DL+CL+0.25(SL)+0.7(TL)+SM+AX+FEM |
| Case 4f: 1.25(DL+CL)+1.4(WL-AX)+1.1(TL)+LL | Case 9d: DL+CL+0.25(SL)+0.7(TL)+SM-AX+FEM |
| Case 5a: 0.9(DL)+1.4(WL+AX) | Case 9e: DL+CL+LL+1.1(TL)+SM+AX+FEM |
| Case 5b: 0.9(DL)+1.4(WL-AX) | Case 9f: DL+CL+LL+1.1(TL)+SM-AX+FEM |
| Case 5c: 0.9(DL)+1.4(WL+AX+IP) | Case 10a: DL+SM+AX |
| Case 5d: 0.9(DL)+1.4(WL-AX+IP) | Case 10b: DL+SM-AX |
| Case 5e: DL+SM+AX | Case 10c: DL+CL+SM+AX |
| Case 5f: DL+SM-AX | Case 10d: DL+CL+SM-AX |

STRESS ANALYSIS - PAGE 1



NEW MILLENNIUM
BUILDING SYSTEMS

Job Number: 8010-0704	Job Name: 10-123 BARRHAVEN FIRE STATION - SHOPORDERS	Date Run: 11/19/2010 4:17:37 PM
Location: OTTAWA, ON	Joist Description: Deep Long Span 58DLH586/267	Mark: TJ33

Geometry

Base Length: 67-7 3/8	Working Length: 67-3 3/8	Joist Depth: 58.00	Effective Depth: 56.01	BC Panel Length: 6 @ 9-4	Shape: Parallel Chords
---------------------------------	------------------------------------	------------------------------	----------------------------------	------------------------------------	----------------------------------

Variable	Left End	Right End
BC Panel	5-9 5/8	5-9 5/8
TC Panel	5-2 3/4	5-2 3/4
First Half	4-8	4-8 1/8
First Diag.	10-5 5/8	10-5 3/4
Depth	58.00	58.00

Deflection Case 2a: LL (Max Deflection: -1.50 in-Y, -0.25 in-X)

Loads, *** All loads are factored ***

Load Type	Category	Load1	Load2	Position	Direction	Loc/Begin	Sp/End
Uniform (plf)	DL	184.50	184.50	TC	+	0-0	67-7 3/8
Uniform (plf)	LL	400.50	400.50	TC	+	0-0	67-7 3/8
Net Uplift (plf)	WL	250.00	250.00	TC	-	0-0	67-7 3/8
Conc Load (lbs)	LL	3,375.00	0.00	TC	+	7-4	7-4
Conc Load (lbs)	LL	3,375.00	0.00	TC	+	22-10	22-10
Conc Load (lbs)	LL	3,375.00	0.00	TC	+	25-8 1/2	25-8 1/2
Conc anywhere (lbs)	TL	315.00	0.00	TC	+	33-9 3/4	0-0
Conc anywhere (lbs)	TL	315.00	0.00	BC	+	33-9 3/4	0-0
Conc Load (lbs)	LL	3,375.00	0.00	TC	+	41-2 1/4	41-2 1/4
Conc Load (lbs)	LL	3,375.00	0.00	TC	+	44-1	44-1
Conc Load (lbs)	DL	625.00	0.00	BC	+	50-11 1/2	56-11 1/2
Uniform (plf)	LL	0.00	500.00	TC	+	52-6 1/2	68-3
Conc Load (lbs)	LL	3,375.00	0.00	TC	+	59-6 7/8	59-6 7/8

Stress Analysis Summary

Int. Panel TC: 56.00	Max Panel BC: 112.13	Reaction LE: 30,960.78	Reaction RE: 34,324.96	Minimum Shear: 8,581.24	Max TC Comp.: 117,054.50	Max BC Tension: 115,908.13
--------------------------------	--------------------------------	----------------------------------	----------------------------------	-----------------------------------	------------------------------------	--------------------------------------

Member	TC Tension	TC Compression	BC Tension	BC Compression	Web Tension	Web Comp.	Web Length	PP Dist.
W2	9,598.46	37,816.73	0.00	0.00	49,675.25	12,462.96	87.81	0-2
V1S	9,436.88	37,045.59	0.00	0.00	1,327.49	8,028.11	56.43	5-2 3/4
W3	9,436.88	37,045.59	62,136.12	16,082.54	9,388.80	35,827.53	79.20	5-9 5/8
W4	21,446.71	81,666.37	62,136.12	16,082.54	28,420.96	7,590.37	79.20	10-5 5/8
W5	21,446.71	81,666.37	97,852.34	25,618.55	6,057.03	24,437.88	79.20	15-1 5/8
W6	28,598.05	110,623.21	97,852.34	25,618.55	18,904.79	4,370.70	79.20	19-9 5/8
V3	28,598.05	110,623.21	97,852.34	25,618.55	1,192.50	8,616.03	56.01	24-5 5/8
W7	28,598.05	110,623.21	115,908.13	30,385.22	3,000.07	12,134.87	79.20	24-5 5/8
W8	30,980.06	117,054.50	115,908.13	30,385.22	12,134.87	3,000.07	79.20	29-1 5/8
V4	30,980.06	117,054.50	115,908.13	30,385.22	1,192.50	3,945.27	56.01	33-9 5/8

* Symmetrical Joist

Standard Verticals

Member	Position	Max Tension	Max Comp.	Length
V2	Interior	1,642.50	8,616.03	56.01

STRESS ANALYSIS - PAGE 2



NEW MILLENNIUM
BUILDING SYSTEMS

Job Number: 8010-0704	Job Name: 10-123 BARRHAVEN FIRE STATION - SHOPORDERS	Date Run: 11/19/2010 4:17:37 PM
Location: OTTAWA, ON	Joist Description: Deep Long Span 58DLH586/267	Mark: TJ33

Chord Properties

Chord	Area	Rx	Rz	Ryy	Y	Ix	Q	Material
TC	2.2897	1.0781	0.6883	1.8998	1.0018	2.6613	1.0000	39 = 3 1/2 x 3 1/2 x .344
BC	2.0930	1.0824	0.6899	1.8930	0.9905	2.4522	0.9871	38 = 3 1/2 x 3 1/2 x .313

Axial and Bending Analysis

K: 0.75	Fy: 50,000.00	Fb: 45,000.00	Mom of Inertia: 6,865.23	LL 300: 1,010.54	TL 406: 746.71	Max Bridg TC: 26-11	Max Bridg BC: 27-5 1/8
-------------------	-------------------------	-------------------------	------------------------------------	----------------------------	--------------------------	-------------------------------	----------------------------------

Top Chord Check	End Panel LE	First Panel LE	Interior Panel	First Panel RE	End Panel RE	
Length	60.75	62.88	56.00	63.00	60.75	Gap Between Chords: 1.1250
Bending Load	567.66	567.66	567.66	811.05	983.16	Min Weld Len 2X: 0.8408
Axial Load	35,219.22	34,601.41	117,054.50	37,045.59	37,816.73	Max Load Fillers TC: 179,520.06
fa	7,690.91	7,556.00	25,561.50	8,089.74	8,258.14	Max Load no Fillers TC: 154,455.92
Maximum K L/r	88.26	91.34	61.02	91.53	88.26	TC OAL/Ryy: 424.9757
Fcr	28,289.52	27,165.58	38,084.24	27,099.69	28,289.52	BC Stress: 29,360.51
Fa	25,460.56	24,449.02	34,275.81	24,389.72	25,460.56	BC L/Rz: 162.5188
F'e	90,143.57	84,153.34	188,594.38	83,819.73	90,143.57	TC Shear Stress: 13,805.56
Cm	0.9716	0.9701	0.9398	0.9678	0.9695	BC Shear Stress: 15,166.45
Panel Point Moment	21571.83	20904.39	13995.63	29215.44	35735.37	
Mid Panel Moment	15331.52	8648.78	7559.27	11842.77	25008.17	
Panel Point fb	10124.80	9811.54	6568.89	13712.36	16772.51	
Mid Panel fb	2885.53	1627.78	1422.72	2228.91	4706.76	
Fillers	0	0	0	0	0	
Panel Point Stress	17,815.72	17,367.54	32,130.39	21,802.10	25,030.65	
Mid Panel Stress	0.3632	0.3437	0.7769	0.3794	0.4247	

Web Design

Member	Web Tension	Allow Tension	Web Comp	Allow Comp	Weld	Qty	Material
W2	49,675.25	51,226.85	12,462.96	15,372.24	13.52 x 0.165	2	A32 = 1.8750 x .165
W3	9,388.80	84,582.09	35,827.53	39,983.94	8.58 x 0.188	2	22 = 2 x 2 x .248
W4	28,420.96	37,148.29	7,590.37	8,139.94	6.81 x 0.188	1	20 = 2 x 2 x .216
W5	6,057.03	56,851.68	24,437.88	26,905.47	6.73 x 0.163	2	17 = 2 x 2 x .163
W6	18,904.79	36,889.49	4,370.70	4,433.71	4.53 x 0.188	1	C38 = 1.125 x 1.844 x .200
W7	3,000.07	43,636.64	12,134.87	16,668.89	3.81 x 0.143	2	14 = 1 3/4 x 1 3/4 x .143
W8	12,134.87	25,317.00	3,000.07	3,167.84	3.34 x 0.163	1	C32 = 1.125 x 1.479 x .163
V1	1,327.49	41,419.47	8,028.11	8,625.45	2.00 x 0.188	1	C40 = 1.125 x 2.006 x .209
V2	1,642.50	21,718.85	8,616.03	4,977.27	2.00 x 0.150	1	C28 = 1.125 x 1.347 x .150

* Symmetrical Joist

STRESS ANALYSIS - PAGE 3



NEW MILLENNIUM
BUILDING SYSTEMS

Job Number: 8010-0704	Job Name: 10-123 BARRHAVEN FIRE STATION - SHOPORDERS	Date Run: 11/19/2010 4:17:37 PM
Location: OTTAWA, ON	Joist Description: Deep Long Span 58DLH586/267	Mark: TJ33

TCX Design

TCX Left		TCX Right	
TCX Length	0-0 1/2	TCX Length	0-0
TCX Type	R	TCX Type	R
TCX Depth	7	TCX Depth	7
BPL Length	0-6	BPL Length	0-6
Clear Bearing	0-8 7/8	Clear Bearing	0-6 3/8
BPL Material: 69L = 2 x 3 x .250		BPL Material: 69L = 2 x 3 x .250	

Total Load	585.00	Total Load	585.00
Reqd TL Def L/80	0.01	Reqd TL Def L/80	0.00
Live Load	400.50	Live Load	400.50
Reqd LL Def L/120	0.00	Reqd LL Def L/120	0.00
Section Modulus	2.1306	Section Modulus	0.0000
Reqd SM	0.0001	Reqd SM	0.0000
Mom of Inertia	5.3227	Mom of Inertia	0.0000
Reqd MI	0.0000	Reqd MI	0.0000

Seat Type: T-Plate

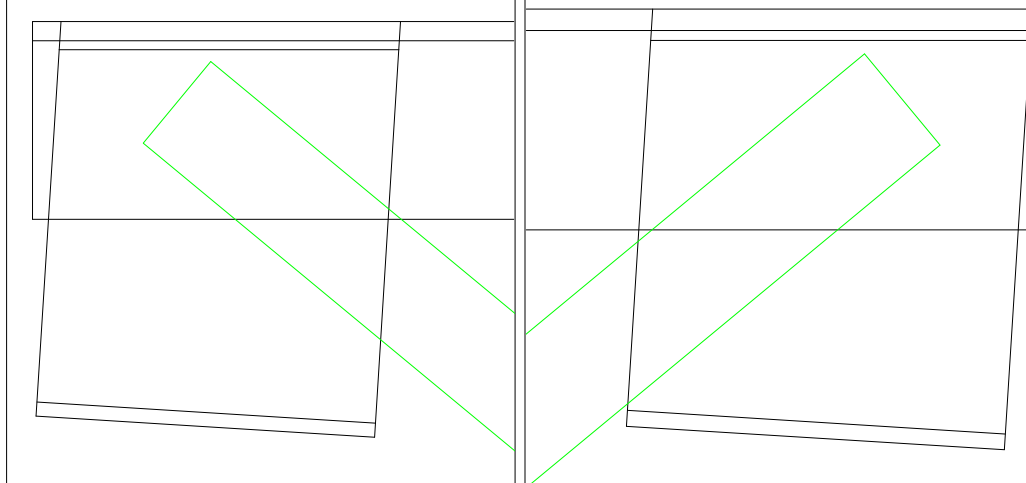

LSD Design

- | | |
|--|--|
| Case 1a: DL | Case 6a: 1.25(DL)+0.5(CL+SL)+1.4(WL+AX)+0.8(TL) |
| Case 1b: 1.4(DL) | Case 6b: 1.25(DL)+0.5(CL+SL)+1.4(WL-AX)+0.8(TL) |
| Case 2a: LL | Case 6c: 1.25(DL)+0.5(CL+SL)+1.4(WL+AX+IP)+0.8(TL) |
| Case 2b: SL | Case 6d: 1.25(DL)+0.5(CL+SL)+1.4(WL-AX+IP)+0.8(TL) |
| Case 3a: 1.25(DL+CL)+1.5(TL+LL) | Case 7a: 1.25(DL+CL)+0.4(WL+AX)+1.5(TL+LL) |
| Case 3b: 1.25(DL+CL)+1.5(TL+SL) | Case 7b: 1.25(DL+CL)+0.4(WL-AX)+1.5(TL+LL) |
| Case 3c: 1.25(DL+CL)+1.5(TL+LL+FEM) | Case 7c: 1.25(DL+CL)+0.4(WL+AX+IP)+1.5(TL+LL) |
| Case 3d: 1.25(DL+CL)+1.5(TL+SL+FEM) | Case 7d: 1.25(DL+CL)+0.4(WL-AX+IP)+1.5(TL+LL) |
| Case 3e: DL+CL+TL+LL | Case 8a: 1.25(DL+CL)+0.4(WL+AX)+1.5(TL+SL) |
| Case 3f: DL+CL+TL+SL | Case 8b: 1.25(DL+CL)+0.4(WL-AX)+1.5(TL+SL) |
| Case 4a: 1.25(DL)+0.5(CL+LL)+1.4(WL+AX)+0.8(TL) | Case 8c: 1.25(DL+CL)+0.4(WL+AX+IP)+1.5(TL+SL) |
| Case 4b: 1.25(DL)+0.5(CL+LL)+1.4(WL-AX)+0.8(TL) | Case 8d: 1.25(DL+CL)+0.4(WL-AX+IP)+1.5(TL+SL) |
| Case 4c: 1.25(DL)+0.5(CL+LL)+1.4(WL+AX+IP)+0.8(TL) | Case 9a: DL+CL+0.5(LL)+0.7(TL)+SM+AX+FEM |
| Case 4d: 1.25(DL)+0.5(CL+LL)+1.4(WL-AX+IP)+0.8(TL) | Case 9b: DL+CL+0.5(LL)+0.7(TL)+SM-AX+FEM |
| Case 4e: 1.25(DL+CL)+1.4(WL+AX)+1.1(TL)+LL | Case 9c: DL+CL+0.25(SL)+0.7(TL)+SM+AX+FEM |
| Case 4f: 1.25(DL+CL)+1.4(WL-AX)+1.1(TL)+LL | Case 9d: DL+CL+0.25(SL)+0.7(TL)+SM-AX+FEM |
| Case 5a: 0.9(DL)+1.4(WL+AX) | Case 9e: DL+CL+LL+1.1(TL)+SM+AX+FEM |
| Case 5b: 0.9(DL)+1.4(WL-AX) | Case 9f: DL+CL+LL+1.1(TL)+SM-AX+FEM |
| Case 5c: 0.9(DL)+1.4(WL+AX+IP) | Case 10a: DL+SM+AX |
| Case 5d: 0.9(DL)+1.4(WL-AX+IP) | Case 10b: DL+SM-AX |
| Case 5e: DL+SM+AX | Case 10c: DL+CL+SM+AX |
| Case 5f: DL+SM-AX | Case 10d: DL+CL+SM-AX |

STRESS ANALYSIS - PAGE 1



NEW MILLENNIUM
BUILDING SYSTEMS

Job Number: 8010-0704	Job Name: 10-123 BARRHAVEN FIRE STATION - SHOPORDERS	Date Run: 11/19/2010 4:17:19 PM
Location: OTTAWA, ON	Joist Description: Deep Long Span 58DLH515/235	Mark: TJ34

Geometry

Base Length: 80-11 3/4	Working Length: 80-7 3/4	Joist Depth: 58.00	Effective Depth: 54.88	BC Panel Length: 7 @ 9-4	Shape: Parallel Chords
----------------------------------	------------------------------------	------------------------------	----------------------------------	------------------------------------	----------------------------------

Variable	Left End	Right End
BC Panel	7-9 7/8	7-9 7/8
TC Panel	6-2 7/8	6-2 7/8
First Half	4-8	4-8
First Diag.	12-5 7/8	12-5 7/8
Depth	58.00	58.00

Deflection Case 2a: LL (Max Deflection: -1.53 in-Y, -0.18 in-X)

Loads, *** All loads are factored ***

Load Type	Category	Load1	Load2	Position	Direction	Loc/Begin	Sp/End
Uniform (plf)	DL	162.50	162.50	TC	+	0-0	80-11 3/4
Uniform (plf)	LL	352.50	352.50	TC	+	0-0	80-11 3/4
Net Uplift (plf)	WL	250.00	250.00	TC	-	0-0	80-11 3/4
Conc Load (lbs)	LL	3,375.00	0.00	TC	+	6-11	6-11
Conc Load (lbs)	LL	3,375.00	0.00	TC	+	22-5	22-5
Conc Load (lbs)	LL	3,375.00	0.00	TC	+	25-3 1/2	25-3 1/2
Conc anywhere (lbs)	TL	315.00	0.00	BC	+	40-5 7/8	0-0
Conc anywhere (lbs)	TL	315.00	0.00	TC	+	40-5 7/8	0-0
Conc Load (lbs)	LL	3,375.00	0.00	TC	+	40-9 1/4	40-9 1/4
Conc Load (lbs)	LL	3,375.00	0.00	TC	+	43-8	43-8
Uniform (plf)	LL	338.00	338.00	TC	+	52-1 1/2	81-0 1/4
Conc Load (lbs)	LL	3,375.00	0.00	TC	+	59-1 7/8	59-1 7/8

Stress Analysis Summary

Int. Panel TC: 56.00	Max Panel BC: 112.00	Reaction LE: 35,401.35	Reaction RE: 38,109.87	Minimum Shear: 9,527.47	Max TC Comp.: 166,589.80	Max BC Tension: 168,349.03
--------------------------------	--------------------------------	----------------------------------	----------------------------------	-----------------------------------	------------------------------------	--------------------------------------

Member	TC Tension	TC Compression	BC Tension	BC Compression	Web Tension	Web Comp.	Web Length	PP Dist.
W2	15,909.40	58,938.75	0.00	0.00	69,263.84	18,531.68	107.02	0-2
V1S	15,365.72	57,119.20	0.00	0.00	1,661.85	7,988.36	58.08	6-2 7/8
W3	15,365.72	57,119.20	87,680.86	23,460.45	11,333.89	43,101.38	78.41	7-9 7/8
W4	30,135.63	113,491.66	87,680.86	23,460.45	36,449.39	9,346.28	78.41	12-5 7/8
W5	30,135.63	113,491.66	135,240.61	35,597.14	7,646.96	31,298.32	78.41	17-1 7/8
W6	39,844.98	149,483.92	135,240.61	35,597.14	22,418.53	5,947.64	78.41	21-9 7/8
V3	39,844.98	149,483.92	135,240.61	35,597.14	1,189.42	6,804.34	54.88	26-5 7/8
W7	39,844.98	149,483.92	159,665.41	42,879.15	4,248.31	14,683.84	78.41	26-5 7/8
W8	44,699.65	166,589.80	159,665.41	42,879.15	13,611.93	3,670.81	78.41	31-1 7/8
V4	44,699.65	166,589.80	159,665.41	42,879.15	1,189.42	3,866.28	54.88	35-9 7/8
W9	44,699.65	166,589.80	168,349.03	45,306.49	3,670.81	13,611.93	78.41	35-9 7/8

* Symmetrical Joist

Standard Verticals

Member	Position	Max Tension	Max Comp.	Length
V2	Interior	1,189.42	6,804.34	54.88

STRESS ANALYSIS - PAGE 2



Job Number: 8010-0704	Job Name: 10-123 BARRHAVEN FIRE STATION - SHOPORDERS	Date Run: 11/19/2010 4:17:19 PM
Location: OTTAWA, ON		Joist Description: Deep Long Span 58DLH515/235
		Mark: TJ34

Chord Properties

Chord	Area	Rx	Rz	Ryy	Y	Ix	Q	Material
TC	5.7500	1.8607	1.1847	2.9176	1.6848	19.9078	0.9613	50 = 6 x 6 x .500
BC	4.7500	1.5390	0.9829	2.5210	1.4342	11.2503	1.0000	47 = 5 x 5 x .500

Axial and Bending Analysis

K: 0.75	Fy: 50,000.00	Fb: 45,000.00	Mom of Inertia: 15,700.34	LL 300: 1,341.98	TL 489: 823.30	Max Bridg TC: 41-4	Max Bridg BC: 45-8 5/8
-------------------	-------------------------	-------------------------	-------------------------------------	----------------------------	--------------------------	------------------------------	----------------------------------

Top Chord Check	End Panel LE	First Panel LE	Interior Panel	First Panel RE	End Panel RE	Gap Between Chords: 1.1250
Length	72.88	75.00	56.00	75.00	72.88	Min Weld Len 2X: 1.1967
Bending Load	499.74	499.74	499.74	816.61	816.61	Max Load Fillers TC: 484,563.25
Axial Load	56,125.90	53,985.49	166,589.80	57,119.20	58,938.75	Max Load no Fillers TC: 461,365.13
fa	4,880.51	4,694.39	14,486.07	4,966.89	5,125.11	TC OAL/Ryy: 331.6915
Maximum K L/r	61.51	63.30	35.45	63.30	61.51	BC Stress: 18,238.64
Fcr	36,841.47	36,266.29	44,001.90	36,266.29	36,841.47	BC L/Rz: 113.9466
Fa	33,157.32	32,639.66	39,601.71	32,639.66	33,157.32	TC Shear Stress: 6,459.87
F'e	186,593.61	176,169.77	561,765.81	176,169.77	186,593.61	BC Shear Stress: 7,762.78
Cm	0.9913	0.9911	0.9885	0.9906	0.9908	
Panel Point Moment	27548.11	26424.15	12516.55	42143.51	43265.08	
Mid Panel Moment	19137.01	11224.11	6819.73	17467.26	29688.93	
Panel Point fb	2985.66	2863.85	1356.54	4567.51	4689.06	
Mid Panel fb	809.77	474.94	288.57	739.12	1256.27	
Fillers	0	0	0	0	0	
Panel Point Stress	7,866.17	7,558.24	15,842.61	9,534.40	9,814.17	
Mid Panel Stress	0.0927	0.0831	0.3718	0.0936	0.1070	

Web Design

Member	Web Tension	Allow Tension	Web Comp	Allow Comp	Weld	Qty	Material
W2	69,263.84	74,296.57	18,531.68	20,062.37	16.58 x 0.188	2	20 = 2 x 2 x .216
W3	11,333.89	92,268.59	43,101.38	57,129.21	10.32 x 0.188	2	25 = 2 1/2 x 2 1/2 x .212
W4	36,449.39	42,291.04	9,346.28	9,395.65	8.73 x 0.188	1	22 = 2 x 2 x .248
W5	7,646.96	74,296.57	31,298.32	35,814.86	7.49 x 0.188	2	20 = 2 x 2 x .216
W6	22,418.53	28,425.84	5,947.64	6,442.66	6.17 x 0.163	1	17 = 2 x 2 x .163
W7	4,248.31	43,636.64	14,683.84	16,975.48	4.61 x 0.143	2	14 = 1 3/4 x 1 3/4 x .143
W8	13,611.93	36,889.49	3,670.81	4,513.32	3.26 x 0.188	1	C38 = 1.125 x 1.844 x .200
W9	3,670.81	43,636.64	13,611.93	16,975.48	4.27 x 0.143	2	14 = 1 3/4 x 1 3/4 x .143
V1	1,661.85	41,419.47	7,988.36	8,240.46	2.00 x 0.188	1	C40 = 1.125 x 2.006 x .209
V2	1,189.42	16,459.83	6,804.34	4,008.67	2.00 x 0.134	1	C22 = 1.125 x 1.086 x .134

* Symmetrical Joist

STRESS ANALYSIS - PAGE 3



NEW MILLENNIUM
BUILDING SYSTEMS

Job Number: 8010-0704	Job Name: 10-123 BARRHAVEN FIRE STATION - SHOPORDERS	Date Run: 11/19/2010 4:17:19 PM
Location: OTTAWA, ON	Joist Description: Deep Long Span 58DLH515/235	Mark: TJ34

TCX Design

TCX Left		TCX Right	
TCX Length	0-5 1/2	TCX Length	0-0 1/2
TCX Type	R	TCX Type	R
TCX Depth	7	TCX Depth	7
BPL Length	0-11 1/2	BPL Length	0-6 1/2
Clear Bearing	1-3 3/8	Clear Bearing	0-7 3/4
BPL Material: 50 = 6 x 6 x .500		BPL Material: 50 = 6 x 6 x .500	
Total Load	515.00	Total Load	515.00
Reqd TL Def L/80	0.07	Reqd TL Def L/80	0.01
Live Load	352.50	Live Load	352.50
Reqd LL Def L/120	0.05	Reqd LL Def L/120	0.00
Section Modulus	9.2268	Section Modulus	9.2268
Reqd SM	0.0153	Reqd SM	0.0001
Mom of Inertia	39.8157	Mom of Inertia	39.8157
Reqd MI	0.0017	Reqd MI	0.0000
Seat Type: Lapped		Seat Type: Lapped	

LSD Design

- | | |
|--|--|
| Case 1a: DL | Case 6a: 1.25(DL)+0.5(CL+SL)+1.4(WL+AX)+0.8(TL) |
| Case 1b: 1.4(DL) | Case 6b: 1.25(DL)+0.5(CL+SL)+1.4(WL-AX)+0.8(TL) |
| Case 2a: LL | Case 6c: 1.25(DL)+0.5(CL+SL)+1.4(WL+AX+IP)+0.8(TL) |
| Case 2b: SL | Case 6d: 1.25(DL)+0.5(CL+SL)+1.4(WL-AX+IP)+0.8(TL) |
| Case 3a: 1.25(DL+CL)+1.5(TL+LL) | Case 7a: 1.25(DL+CL)+0.4(WL+AX)+1.5(TL+LL) |
| Case 3b: 1.25(DL+CL)+1.5(TL+SL) | Case 7b: 1.25(DL+CL)+0.4(WL-AX)+1.5(TL+LL) |
| Case 3c: 1.25(DL+CL)+1.5(TL+LL+FEM) | Case 7c: 1.25(DL+CL)+0.4(WL+AX+IP)+1.5(TL+LL) |
| Case 3d: 1.25(DL+CL)+1.5(TL+SL+FEM) | Case 7d: 1.25(DL+CL)+0.4(WL-AX+IP)+1.5(TL+LL) |
| Case 3e: DL+CL+TL+LL | Case 8a: 1.25(DL+CL)+0.4(WL+AX)+1.5(TL+SL) |
| Case 3f: DL+CL+TL+SL | Case 8b: 1.25(DL+CL)+0.4(WL-AX)+1.5(TL+SL) |
| Case 4a: 1.25(DL)+0.5(CL+LL)+1.4(WL+AX)+0.8(TL) | Case 8c: 1.25(DL+CL)+0.4(WL+AX+IP)+1.5(TL+SL) |
| Case 4b: 1.25(DL)+0.5(CL+LL)+1.4(WL-AX)+0.8(TL) | Case 8d: 1.25(DL+CL)+0.4(WL-AX+IP)+1.5(TL+SL) |
| Case 4c: 1.25(DL)+0.5(CL+LL)+1.4(WL+AX+IP)+0.8(TL) | Case 9a: DL+CL+0.5(LL)+0.7(TL)+SM+AX+FEM |
| Case 4d: 1.25(DL)+0.5(CL+LL)+1.4(WL-AX+IP)+0.8(TL) | Case 9b: DL+CL+0.5(LL)+0.7(TL)+SM-AX+FEM |
| Case 4e: 1.25(DL+CL)+1.4(WL+AX)+1.1(TL)+LL | Case 9c: DL+CL+0.25(SL)+0.7(TL)+SM+AX+FEM |
| Case 4f: 1.25(DL+CL)+1.4(WL-AX)+1.1(TL)+LL | Case 9d: DL+CL+0.25(SL)+0.7(TL)+SM-AX+FEM |
| Case 5a: 0.9(DL)+1.4(WL+AX) | Case 9e: DL+CL+LL+1.1(TL)+SM+AX+FEM |
| Case 5b: 0.9(DL)+1.4(WL-AX) | Case 9f: DL+CL+LL+1.1(TL)+SM-AX+FEM |
| Case 5c: 0.9(DL)+1.4(WL+AX+IP) | Case 10a: DL+SM+AX |
| Case 5d: 0.9(DL)+1.4(WL-AX+IP) | Case 10b: DL+SM-AX |
| Case 5e: DL+SM+AX | Case 10c: DL+CL+SM+AX |
| Case 5f: DL+SM-AX | Case 10d: DL+CL+SM-AX |

STRESS ANALYSIS - PAGE 1



NEW MILLENNIUM
BUILDING SYSTEMS

Job Number: 8010-0704	Job Name: 10-123 BARRHAVEN FIRE STATION - SHOPORDERS	Date Run: 11/19/2010 3:57:17 PM
Location: OTTAWA, ON	Joist Description: Deep Long Span 58DLH562/238	Mark: TJ36

Geometry

Base Length: 80-11 3/4	Working Length: 80-7 3/4	Joist Depth: 58.00	Effective Depth: 56.17	BC Panel Length: 7 @ 9-4	Shape: Parallel Chords
----------------------------------	------------------------------------	------------------------------	----------------------------------	------------------------------------	----------------------------------

Variable	Left End	Right End
BC Panel	7-9 7/8	7-9 7/8
TC Panel	6-2 7/8	6-2 7/8
First Half	4-8	4-8
First Diag.	12-5 7/8	12-5 7/8
Depth	58.00	58.00

Deflection Case 2a: LL (Max Deflection: -1.92 in-Y, -0.29 in-X)

Loads, *** All loads are factored ***

Load Type	Category	Load1	Load2	Position	Direction	Loc/Begin	Sp/End
Uniform (plf)	DL	204.00	204.00	TC	+	0-0	80-11 3/4
Uniform (plf)	LL	357.00	357.00	TC	+	0-0	80-11 3/4
Conc anywhere (lbs)	TL	315.00	0.00	BC	+	40-5 7/8	0-0
Conc anywhere (lbs)	TL	315.00	0.00	TC	+	40-5 7/8	0-0
Net Uplift (plf)	WL	250.00	250.00	TC	-	0-0	80-11 3/4
Conc Load (lbs)	LL	1,700.00	0.00	TC	+	19-11 1/2	25-11 1/2
Conc Load (lbs)	LL	1,700.00	0.00	TC	+	26-11 1/2	32-11 1/2
Conc Load (lbs)	LL	1,700.00	0.00	TC	+	48-11 1/2	54-11 1/2
Uniform (plf)	LL	188.00	188.00	TC	+	52-6 1/2	81-5 1/4
Conc Load (lbs)	LL	1,700.00	0.00	TC	+	54-11 1/2	60-11 1/2
Conc Load (lbs)	LL	1,700.00	0.00	TC	+	72-11 1/2	78-11 1/2

Stress Analysis Summary

Int. Panel TC: 56.00	Max Panel BC: 112.00	Reaction LE: 28,168.55	Reaction RE: 33,261.07	Minimum Shear: 8,315.27	Max TC Comp.: 131,989.67	Max BC Tension: 132,189.08
--------------------------------	--------------------------------	----------------------------------	----------------------------------	-----------------------------------	------------------------------------	--------------------------------------

Member	TC Tension	TC Compression	BC Tension	BC Compression	Web Tension	Web Comp.	Web Length	PP Dist.
W2	15,621.55	49,599.65	0.00	0.00	59,409.28	18,309.34	107.68	0-2
V1S	15,087.71	47,627.29	0.00	0.00	1,665.92	11,656.61	59.29	6-2 7/8
W3	15,087.71	47,627.29	72,046.20	23,035.99	11,257.16	34,770.88	79.31	7-9 7/8
W4	29,590.40	91,905.74	72,046.20	23,035.99	28,997.66	9,283.01	79.31	12-5 7/8
W5	29,590.40	91,905.74	108,280.27	34,953.09	7,595.19	24,165.32	79.31	17-1 7/8
W6	39,124.07	120,999.48	108,280.27	34,953.09	20,468.35	5,907.37	79.31	21-9 7/8
V3	39,124.07	120,999.48	108,280.27	34,953.09	1,195.23	4,784.42	56.17	26-5 7/8
W7	39,124.07	120,999.48	128,708.88	42,103.35	4,219.55	14,793.10	79.31	26-5 7/8
W8	43,890.91	131,989.67	128,708.88	42,103.35	11,742.28	3,645.96	79.31	31-1 7/8
V4	43,890.91	131,989.67	128,708.88	42,103.35	1,195.23	3,934.42	56.17	35-9 7/8
W9	43,890.91	131,989.67	132,189.08	44,486.77	10,103.18	11,742.28	79.31	35-9 7/8

* Symmetrical Joist

Standard Verticals

Member	Position	Max Tension	Max Comp.	Length
V2	Interior	1,915.33	6,485.28	56.17

STRESS ANALYSIS - PAGE 2



Job Number: 8010-0704	Job Name: 10-123 BARRHAVEN FIRE STATION - SHOPORDERS	Date Run: 11/19/2010 3:57:17 PM
Location: OTTAWA, ON	Joist Description: Deep Long Span 58DLH562/238	Mark: TJ36

Chord Properties

Chord	Area	Rx	Rz	Ryy	Y	Ix	Q	Material
TC	1.9266	1.0861	0.6914	1.8874	0.9811	2.2726	0.9552	37 = 3 1/2 x 3 1/2 x .287
BC	1.6070	0.9260	0.5907	1.6920	0.8536	1.3780	1.0000	34 = 3 x 3 x .281

Axial and Bending Analysis

K: 0.75	Fy: 50,000.00	Fb: 45,000.00	Mom of Inertia: 5,531.61	LL 360: 394.01	LL 240: 591.01	Max Bridg TC: 26-8 7/8	Max Bridg BC: 17-0 1/4
-------------------	-------------------------	-------------------------	------------------------------------	--------------------------	--------------------------	----------------------------------	----------------------------------

Top Chord Check	End Panel LE	First Panel LE	Interior Panel	First Panel RE	End Panel RE	
Length	72.88	75.00	56.00	75.00	72.88	Gap Between Chords: 1.1250
Bending Load	547.19	547.19	547.19	723.44	723.44	Min Weld Len 2X: 0.9481
Axial Load	42,365.86	41,196.55	131,989.67	47,627.29	49,599.65	Max Load Fillers TC: 144,375.41
fa	10,994.80	10,691.34	34,254.01	12,360.25	12,872.12	Max Load no Fillers TC: 125,224.47
Maximum K L/r	105.41	108.48	40.50	108.48	105.41	TC OAL/Ryy: 512.7460
Fcr	21,981.56	20,995.17	42,588.91	20,995.17	21,981.56	BC Stress: 43,672.14
Fa	19,783.40	18,895.65	38,330.02	18,895.65	19,783.40	BC L/Rz: 189.6082
F'e	63,570.96	60,019.64	191,389.14	60,019.64	63,570.96	TC Shear Stress: 16,767.82
Cm	0.9423	0.9406	0.9205	0.9314	0.9325	BC Shear Stress: 19,999.03
Panel Point Moment	29901.52	28777.92	13549.86	37521.23	38643.50	
Mid Panel Moment	20717.02	12158.94	7336.39	15631.46	26586.14	
Panel Point fb	16571.39	15948.69	7509.32	20794.23	21416.19	
Mid Panel fb	4471.88	2624.57	1583.60	3374.13	5738.76	
Fillers	0	0	4	0	0	
Panel Point Stress	27,566.20	26,640.04	41,763.33	33,154.48	34,288.31	
Mid Panel Stress	0.6636	0.6295	0.9313	0.7384	0.7934	

Web Design

Member	Web Tension	Allow Tension	Web Comp	Allow Comp	Weld	Qty	Material
W2	59,409.28	74,296.57	18,309.34	19,815.62	14.23 x 0.188	2	20 = 2 x 2 x .216
W3	11,257.16	74,296.57	34,770.88	35,213.73	8.33 x 0.188	2	20 = 2 x 2 x .216
W4	28,997.66	33,914.79	9,283.01	9,479.74	10.01 x 0.130	2	09A = 1 1/2 x 1 1/2 x .130
W5	7,595.19	56,851.68	24,165.32	26,852.47	6.66 x 0.163	2	17 = 2 x 2 x .163
W6	20,468.35	28,425.84	5,907.37	6,296.60	5.64 x 0.163	1	17 = 2 x 2 x .163
W7	4,219.55	43,636.64	14,793.10	16,625.97	4.64 x 0.143	2	14 = 1 3/4 x 1 3/4 x .143
W8	11,742.28	36,889.49	3,645.96	4,422.67	2.81 x 0.188	1	C38 = 1.125 x 1.844 x .200
W9	10,103.18	43,636.64	11,742.28	16,625.97	3.69 x 0.143	2	14 = 1 3/4 x 1 3/4 x .143
V1	1,665.92	32,519.82	11,656.61	12,034.01	2.80 x 0.187	1	A36 = 2.0938 x .187
V2	1,915.33	21,718.85	6,485.28	4,954.50	2.00 x 0.150	1	C28 = 1.125 x 1.347 x .150

* Symmetrical Joist

STRESS ANALYSIS - PAGE 3



NEW MILLENNIUM
BUILDING SYSTEMS

Job Number: 8010-0704	Job Name: 10-123 BARRHAVEN FIRE STATION - SHOPORDERS	Date Run: 11/19/2010 3:57:17 PM
Location: OTTAWA, ON	Joist Description: Deep Long Span 58DLH562/238	Mark: TJ36

TCX Design

TCX Left		TCX Right	
TCX Length	0-0 1/2	TCX Length	0-5 1/2
TCX Type	R	TCX Type	R
TCX Depth	7	TCX Depth	7
BPL Length	0-6	BPL Length	0-6
Clear Bearing	0-10 7/8	Clear Bearing	1-1 1/8
BPL Material: 69L = 2 x 3 x .250		BPL Material: 69L = 2 x 3 x .250	
Total Load	561.00	Total Load	561.00
Reqd TL Def L/80	0.01	Reqd TL Def L/80	0.07
Live Load	357.00	Live Load	357.00
Reqd LL Def L/120	0.00	Reqd LL Def L/120	0.05
Section Modulus	1.8044	Section Modulus	1.8044
Reqd SM	0.0001	Reqd SM	0.0169
Mom of Inertia	4.5451	Mom of Inertia	4.5451
Reqd MI	0.0000	Reqd MI	0.0019
Seat Type: T-Plate		Seat Type: T-Plate	

LSD Design

- | | |
|--|--|
| Case 1a: DL | Case 6a: 1.25(DL)+0.5(CL+SL)+1.4(WL+AX)+0.8(TL) |
| Case 1b: 1.4(DL) | Case 6b: 1.25(DL)+0.5(CL+SL)+1.4(WL-AX)+0.8(TL) |
| Case 2a: LL | Case 6c: 1.25(DL)+0.5(CL+SL)+1.4(WL+AX+IP)+0.8(TL) |
| Case 2b: SL | Case 6d: 1.25(DL)+0.5(CL+SL)+1.4(WL-AX+IP)+0.8(TL) |
| Case 3a: 1.25(DL+CL)+1.5(TL+LL) | Case 7a: 1.25(DL+CL)+0.4(WL+AX)+1.5(TL+LL) |
| Case 3b: 1.25(DL+CL)+1.5(TL+SL) | Case 7b: 1.25(DL+CL)+0.4(WL-AX)+1.5(TL+LL) |
| Case 3c: 1.25(DL+CL)+1.5(TL+LL+FEM) | Case 7c: 1.25(DL+CL)+0.4(WL+AX+IP)+1.5(TL+LL) |
| Case 3d: 1.25(DL+CL)+1.5(TL+SL+FEM) | Case 7d: 1.25(DL+CL)+0.4(WL-AX+IP)+1.5(TL+LL) |
| Case 3e: DL+CL+TL+LL | Case 8a: 1.25(DL+CL)+0.4(WL+AX)+1.5(TL+SL) |
| Case 3f: DL+CL+TL+SL | Case 8b: 1.25(DL+CL)+0.4(WL-AX)+1.5(TL+SL) |
| Case 4a: 1.25(DL)+0.5(CL+LL)+1.4(WL+AX)+0.8(TL) | Case 8c: 1.25(DL+CL)+0.4(WL+AX+IP)+1.5(TL+SL) |
| Case 4b: 1.25(DL)+0.5(CL+LL)+1.4(WL-AX)+0.8(TL) | Case 8d: 1.25(DL+CL)+0.4(WL-AX+IP)+1.5(TL+SL) |
| Case 4c: 1.25(DL)+0.5(CL+LL)+1.4(WL+AX+IP)+0.8(TL) | Case 9a: DL+CL+0.5(LL)+0.7(TL)+SM+AX+FEM |
| Case 4d: 1.25(DL)+0.5(CL+LL)+1.4(WL-AX+IP)+0.8(TL) | Case 9b: DL+CL+0.5(LL)+0.7(TL)+SM-AX+FEM |
| Case 4e: 1.25(DL+CL)+1.4(WL+AX)+1.1(TL)+LL | Case 9c: DL+CL+0.25(SL)+0.7(TL)+SM+AX+FEM |
| Case 4f: 1.25(DL+CL)+1.4(WL-AX)+1.1(TL)+LL | Case 9d: DL+CL+0.25(SL)+0.7(TL)+SM-AX+FEM |
| Case 5a: 0.9(DL)+1.4(WL+AX) | Case 9e: DL+CL+LL+1.1(TL)+SM+AX+FEM |
| Case 5b: 0.9(DL)+1.4(WL-AX) | Case 9f: DL+CL+LL+1.1(TL)+SM-AX+FEM |
| Case 5c: 0.9(DL)+1.4(WL+AX+IP) | Case 10a: DL+SM+AX |
| Case 5d: 0.9(DL)+1.4(WL-AX+IP) | Case 10b: DL+SM-AX |
| Case 5e: DL+SM+AX | Case 10c: DL+CL+SM+AX |
| Case 5f: DL+SM-AX | Case 10d: DL+CL+SM-AX |

STRESS ANALYSIS - PAGE 1



NEW MILLENNIUM
BUILDING SYSTEMS

Job Number: 8010-0704	Job Name: 10-123 BARRHAVEN FIRE STATION - SHOPORDERS	Date Run: 11/19/2010 3:57:18 PM
Location: OTTAWA, ON		Joist Description: Deep Long Span 58DLH609/277
		Mark: TJ38

Geometry

Base Length: 80-11 3/4	Working Length: 80-7 3/4	Joist Depth: 58.00	Effective Depth: 56.29	BC Panel Length: 7 @ 9-4	Shape: Parallel Chords
----------------------------------	------------------------------------	------------------------------	----------------------------------	------------------------------------	----------------------------------

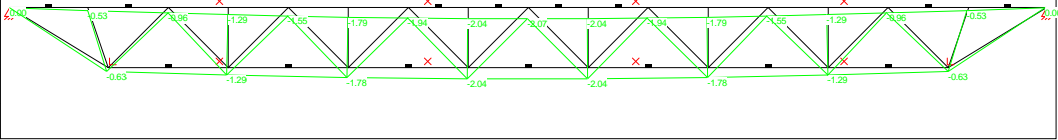
Variable	Left End	Right End	Deflection Case 2a: LL (Max Deflection: -2.07 in-Y, -0.34 in-X) 
BC Panel	7-9 7/8	7-9 7/8	
TC Panel	6-2 7/8	6-2 7/8	
First Half	4-8	4-8	
First Diag.	12-5 7/8	12-5 7/8	
Depth	58.00	58.00	

Loads, *** All loads are factored ***

Load Type	Category	Load1	Load2	Position	Direction	Loc/Begin	Sp/End
Uniform (plf)	DL	193.50	193.50	TC	+	0-0	80-11 3/4
Uniform (plf)	LL	415.50	415.50	TC	+	0-0	80-11 3/4
Conc anywhere (lbs)	TL	315.00	0.00	BC	+	40-5 7/8	0-0
Conc anywhere (lbs)	TL	315.00	0.00	TC	+	40-5 7/8	0-0
Net Uplift (plf)	WL	250.00	250.00	TC	-	0-0	80-11 3/4

Stress Analysis Summary

Int. Panel TC: 56.00	Max Panel BC: 112.00	Reaction LE: 25,182.75	Reaction RE: 25,184.70	Minimum Shear: 6,296.18	Max TC Comp.: 106,521.46	Max BC Tension: 108,091.76
--------------------------------	--------------------------------	----------------------------------	----------------------------------	-----------------------------------	------------------------------------	--------------------------------------

Member	TC Tension	TC Compression	BC Tension	BC Compression	Web Tension	Web Comp.	Web Length	PP Dist.
W2	15,567.02	37,574.83	0.00	0.00	44,666.19	18,256.69	107.75	0-2
V1S	15,035.04	36,308.34	0.00	0.00	1,663.49	5,106.20	59.41	6-2 7/8
W3	15,035.04	36,308.34	55,478.25	22,955.57	11,230.64	27,487.65	79.40	7-9 7/8
W4	29,487.10	71,341.35	55,478.25	22,955.57	22,798.83	9,261.14	79.40	12-5 7/8
W5	29,487.10	71,341.35	84,377.21	34,831.07	7,577.30	18,687.96	79.40	17-1 7/8
W6	38,987.49	94,585.86	84,377.21	34,831.07	14,679.20	5,893.45	79.40	21-9 7/8
W7	38,987.49	94,585.86	101,967.28	41,956.37	4,209.61	10,568.33	79.40	26-5 7/8
W8	43,737.70	106,521.46	101,967.28	41,956.37	8,881.02	3,637.37	79.40	31-1 7/8
W9	43,737.70	106,521.46	108,091.76	44,331.47	3,637.37	8,881.02	79.40	35-9 7/8

* Symmetrical Joist

Standard Verticals

Member	Position	Max Tension	Max Comp.	Length
V2	Interior	1,193.76	4,004.61	56.29

STRESS ANALYSIS - PAGE 2



NEW MILLENNIUM
BUILDING SYSTEMS

Job Number: 8010-0704	Job Name: 10-123 BARRHAVEN FIRE STATION - SHOPORDERS	Date Run: 11/19/2010 3:57:18 PM
Location: OTTAWA, ON		Joist Description: Deep Long Span 58DLH609/277
		Mark: TJ38

Chord Properties

Chord	Area	Rx	Rz	Ryy	Y	Ix	Q	Material
TC	1.6070	0.9260	0.5907	1.6920	0.8536	1.3780	1.0000	34 = 3 x 3 x .281
BC	1.6070	0.9260	0.5907	1.6920	0.8536	1.3780	1.0000	34 = 3 x 3 x .281

Axial and Bending Analysis

K: 0.75	Fy: 50,000.00	Fb: 45,000.00	Mom of Inertia: 5,095.25	LL 360: 362.93	LL 240: 544.39	Max Bridg TC: 23-11 5/8	Max Bridg BC: 17-0 3/4
-------------------	-------------------------	-------------------------	------------------------------------	--------------------------	--------------------------	-----------------------------------	----------------------------------

Top Chord Check	End Panel LE	First Panel LE	Interior Panel	First Panel RE	End Panel RE	
Length	72.88	75.00	56.00	75.00	72.88	Gap Between Chords: 1.1250
Bending Load	591.09	591.09	591.09	591.09	591.09	Min Weld Len 2X: 0.7652
Axial Load	37,574.83	36,308.34	106,521.46	36,308.33	37,574.82	Max Load Fillers TC: 117,120.28
fa	11,690.70	11,296.66	33,142.15	11,296.65	11,690.70	Max Load no Fillers TC: 95,642.31
Maximum K L/r	78.70	80.99	47.40	80.99	78.70	TC OAL/Ryy: 571.9450
Fcr	31,791.03	30,950.52	42,424.75	30,950.52	31,791.03	BC Stress: 36,174.71
Fa	28,611.92	27,855.47	38,182.27	27,855.47	28,611.92	BC L/Rz: 189.6082
F'e	46,214.04	43,632.34	139,133.72	43,632.34	46,214.04	TC Shear Stress: 15,055.56
Cm	0.9157	0.9137	0.8941	0.9137	0.9157	BC Shear Stress: 15,055.56
Panel Point Moment	32079.27	30956.00	14506.04	30956.00	32079.27	
Mid Panel Moment	22179.10	13023.99	7814.48	13023.99	22179.10	
Panel Point fb	24982.47	24107.71	11296.92	24107.71	24982.47	
Mid Panel fb	6869.63	4033.98	2420.41	4033.98	6869.63	
Fillers	1	1	4	1	1	
Panel Point Stress	36,673.18	35,404.36	44,439.07	35,404.36	36,673.17	
Mid Panel Stress	0.5814	0.5078	0.9261	0.5078	0.5814	

Web Design

Member	Web Tension	Allow Tension	Web Comp	Allow Comp	Weld	Qty	Material
W2	44,666.19	74,296.57	18,256.69	19,791.16	10.70 x 0.188	2	20 = 2 x 2 x .216
W3	11,230.64	65,039.63	27,487.65	29,498.59	6.60 x 0.187	2	A36 = 2.0938 x .187
W4	22,798.83	33,914.79	9,261.14	9,458.19	7.87 x 0.130	2	09A = 1 1/2 x 1 1/2 x .130
W5	7,577.30	51,226.85	18,687.96	18,798.18	5.08 x 0.165	2	A32 = 1.8750 x .165
W6	14,679.20	28,425.84	5,893.45	6,282.29	4.04 x 0.163	1	17 = 2 x 2 x .163
W7	4,209.61	40,084.63	10,568.33	11,083.44	3.06 x 0.155	2	12 = 1 1/2 x 1 1/2 x .155
W8	8,881.02	36,889.49	3,637.37	4,413.76	2.13 x 0.188	1	C38 = 1.125 x 1.844 x .200
W9	3,637.37	42,291.04	8,881.02	9,161.77	2.13 x 0.188	1	22 = 2 x 2 x .248
V1	1,663.49	25,317.00	5,106.20	5,196.78	2.00 x 0.163	1	C32 = 1.125 x 1.479 x .163
V2	1,193.76	21,718.85	4,004.61	4,936.19	2.00 x 0.150	1	C28 = 1.125 x 1.347 x .150

* Symmetrical Joist

STRESS ANALYSIS - PAGE 3



NEW MILLENNIUM
BUILDING SYSTEMS

Job Number: 8010-0704	Job Name: 10-123 BARRHAVEN FIRE STATION - SHOPORDERS	Date Run: 11/19/2010 3:57:18 PM
Location: OTTAWA, ON	Joist Description: Deep Long Span 58DLH609/277	Mark: TJ38

TCX Design

TCX Left		TCX Right	
TCX Length	0-5 1/2	TCX Length	0-0 1/2
TCX Type	R	TCX Type	R
TCX Depth	7	TCX Depth	7
BPL Length	0-6	BPL Length	0-6
Clear Bearing	1-4	Clear Bearing	0-8 1/4
BPL Material: 69L = 2 x 3 x .250		BPL Material: 69L = 2 x 3 x .250	

Total Load	609.00	Total Load	609.00
Reqd TL Def L/80	0.07	Reqd TL Def L/80	0.01
Live Load	415.50	Live Load	415.50
Reqd LL Def L/120	0.05	Reqd LL Def L/120	0.00
Section Modulus	1.2841	Section Modulus	1.2841
Reqd SM	0.0181	Reqd SM	0.0001
Mom of Inertia	2.7561	Mom of Inertia	2.7561
Reqd MI	0.0021	Reqd MI	0.0000

Seat Type: T-Plate

Seat Type: T-Plate

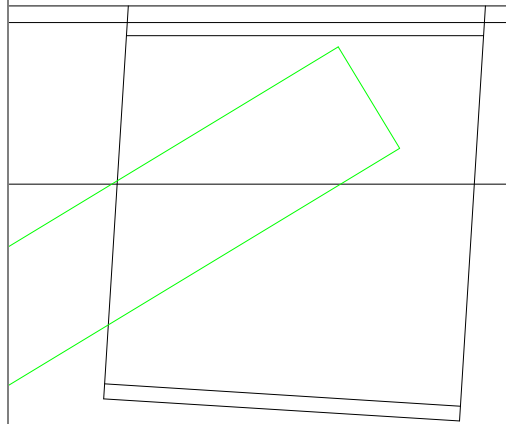
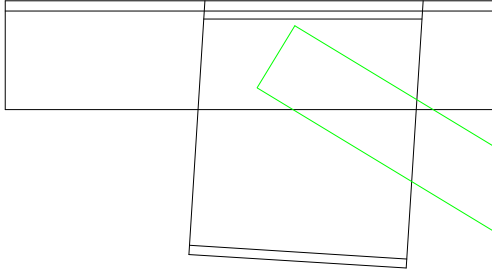

LSD Design

- | | |
|--|--|
| Case 1a: DL | Case 6a: 1.25(DL)+0.5(CL+SL)+1.4(WL+AX)+0.8(TL) |
| Case 1b: 1.4(DL) | Case 6b: 1.25(DL)+0.5(CL+SL)+1.4(WL-AX)+0.8(TL) |
| Case 2a: LL | Case 6c: 1.25(DL)+0.5(CL+SL)+1.4(WL+AX+IP)+0.8(TL) |
| Case 2b: SL | Case 6d: 1.25(DL)+0.5(CL+SL)+1.4(WL-AX+IP)+0.8(TL) |
| Case 3a: 1.25(DL+CL)+1.5(TL+LL) | Case 7a: 1.25(DL+CL)+0.4(WL+AX)+1.5(TL+LL) |
| Case 3b: 1.25(DL+CL)+1.5(TL+SL) | Case 7b: 1.25(DL+CL)+0.4(WL-AX)+1.5(TL+LL) |
| Case 3c: 1.25(DL+CL)+1.5(TL+LL+FEM) | Case 7c: 1.25(DL+CL)+0.4(WL+AX+IP)+1.5(TL+LL) |
| Case 3d: 1.25(DL+CL)+1.5(TL+SL+FEM) | Case 7d: 1.25(DL+CL)+0.4(WL-AX+IP)+1.5(TL+LL) |
| Case 3e: DL+CL+TL+LL | Case 8a: 1.25(DL+CL)+0.4(WL+AX)+1.5(TL+SL) |
| Case 3f: DL+CL+TL+SL | Case 8b: 1.25(DL+CL)+0.4(WL-AX)+1.5(TL+SL) |
| Case 4a: 1.25(DL)+0.5(CL+LL)+1.4(WL+AX)+0.8(TL) | Case 8c: 1.25(DL+CL)+0.4(WL+AX+IP)+1.5(TL+SL) |
| Case 4b: 1.25(DL)+0.5(CL+LL)+1.4(WL-AX)+0.8(TL) | Case 8d: 1.25(DL+CL)+0.4(WL-AX+IP)+1.5(TL+SL) |
| Case 4c: 1.25(DL)+0.5(CL+LL)+1.4(WL+AX+IP)+0.8(TL) | Case 9a: DL+CL+0.5(LL)+0.7(TL)+SM+AX+FEM |
| Case 4d: 1.25(DL)+0.5(CL+LL)+1.4(WL-AX+IP)+0.8(TL) | Case 9b: DL+CL+0.5(LL)+0.7(TL)+SM-AX+FEM |
| Case 4e: 1.25(DL+CL)+1.4(WL+AX)+1.1(TL)+LL | Case 9c: DL+CL+0.25(SL)+0.7(TL)+SM+AX+FEM |
| Case 4f: 1.25(DL+CL)+1.4(WL-AX)+1.1(TL)+LL | Case 9d: DL+CL+0.25(SL)+0.7(TL)+SM-AX+FEM |
| Case 5a: 0.9(DL)+1.4(WL+AX) | Case 9e: DL+CL+LL+1.1(TL)+SM+AX+FEM |
| Case 5b: 0.9(DL)+1.4(WL-AX) | Case 9f: DL+CL+LL+1.1(TL)+SM-AX+FEM |
| Case 5c: 0.9(DL)+1.4(WL+AX+IP) | Case 10a: DL+SM+AX |
| Case 5d: 0.9(DL)+1.4(WL-AX+IP) | Case 10b: DL+SM-AX |
| Case 5e: DL+SM+AX | Case 10c: DL+CL+SM+AX |
| Case 5f: DL+SM-AX | Case 10d: DL+CL+SM-AX |

STRESS ANALYSIS - PAGE 1



NEW MILLENNIUM
BUILDING SYSTEMS

Job Number: 8010-0704	Job Name: 10-123 BARRHAVEN FIRE STATION - SHOPORDERS	Date Run: 11/19/2010 3:57:18 PM
Location: OTTAWA, ON	Joist Description: Deep Long Span 58DLH515/235	Mark: TJ40

Geometry

Base Length: 80-11 3/4	Working Length: 80-7 3/4	Joist Depth: 58.00	Effective Depth: 56.30	BC Panel Length: 7 @ 9-4	Shape: Parallel Chords
----------------------------------	------------------------------------	------------------------------	----------------------------------	------------------------------------	----------------------------------

Variable	Left End	Right End	Deflection Case 2a: LL (Max Deflection: -1.85 in-Y, -0.33 in-X)
BC Panel	7-9 7/8	7-9 7/8	
TC Panel	6-2 7/8	6-2 7/8	
First Half	4-8	4-8	
First Diag.	12-5 7/8	12-5 7/8	
Depth	58.00	58.00	

Loads, *** All loads are factored ***

Load Type	Category	Load1	Load2	Position	Direction	Loc/Begin	Sp/End
Uniform (plf)	DL	162.50	162.50	TC	+	0-0	80-11 3/4
Uniform (plf)	LL	352.50	352.50	TC	+	0-0	80-11 3/4
Conc anywhere (lbs)	TL	315.00	0.00	BC	+	40-5 7/8	0-0
Conc anywhere (lbs)	TL	315.00	0.00	TC	+	40-5 7/8	0-0
Net Uplift (plf)	WL	250.00	250.00	TC	-	0-0	80-11 3/4

Stress Analysis Summary

Int. Panel TC: 56.00	Max Panel BC: 112.00	Reaction LE: 21,392.39	Reaction RE: 21,394.35	Minimum Shear: 5,348.59	Max TC Comp.: 90,431.20	Max BC Tension 91,783.03
--------------------------------	--------------------------------	----------------------------------	----------------------------------	-----------------------------------	-----------------------------------	------------------------------------

Member	TC Tension	TC Compression	BC Tension	BC Compression	Web Tension	Web Comp.	Web Length	PP Dist.
W2	15,507.32	31,848.08	0.00	0.00	37,951.94	18,187.67	107.76	0-2
V1S	14,977.38	30,777.29	0.00	0.00	1,657.41	4,414.39	59.42	6-2 7/8
W3	14,977.38	30,777.29	47,033.42	22,867.54	11,188.69	23,358.43	79.41	7-9 7/8
W4	29,374.02	60,493.70	47,033.42	22,867.54	19,393.73	9,226.55	79.41	12-5 7/8
W5	29,374.02	60,493.70	71,563.62	34,697.50	7,549.00	15,901.97	79.41	17-1 7/8
W6	38,837.98	80,243.17	71,563.62	34,697.50	12,512.30	5,871.44	79.41	21-9 7/8
W7	38,837.98	80,243.17	86,532.37	41,795.48	4,193.89	9,020.54	79.41	26-5 7/8
W8	43,569.97	90,431.20	86,532.37	41,795.48	7,543.65	3,623.78	79.41	31-1 7/8
W9	43,569.97	90,431.20	91,783.03	44,161.46	3,623.78	7,543.65	79.41	35-9 7/8

* Symmetrical Joist

Standard Verticals

Member	Position	Max Tension	Max Comp.	Length
V2	Interior	1,189.42	3,485.49	56.30

STRESS ANALYSIS - PAGE 2



NEW MILLENNIUM
BUILDING SYSTEMS

Job Number: 8010-0704	Job Name: 10-123 BARRHAVEN FIRE STATION - SHOPORDERS	Date Run: 11/19/2010 3:57:18 PM
Location: OTTAWA, ON		Joist Description: Deep Long Span 58DLH515/235
		Mark: TJ40

Chord Properties

Chord	Area	Rx	Rz	Ryy	Y	Ix	Q	Material
TC	1.4375	0.9304	0.5924	1.6850	0.8424	1.2442	0.9613	33 = 3 x 3 x .250
BC	1.6070	0.9260	0.5907	1.6920	0.8536	1.3780	1.0000	34 = 3 x 3 x .281

Axial and Bending Analysis

K: 0.75	Fy: 50,000.00	Fb: 45,000.00	Mom of Inertia: 4,813.46	LL 360: 342.86	LL 240: 514.28	Max Bridg TC: 23-10 1/2	Max Bridg BC: 17-1 1/4
-------------------	-------------------------	-------------------------	------------------------------------	--------------------------	--------------------------	-----------------------------------	----------------------------------

Top Chord Check	End Panel LE	First Panel LE	Interior Panel	First Panel RE	End Panel RE	
Length	72.88	75.00	56.00	75.00	72.88	Gap Between Chords: 1.1250
Bending Load	499.74	499.74	499.74	499.74	499.74	Min Weld Len 2X: 0.6496
Axial Load	31,848.07	30,777.28	90,431.20	30,777.29	31,848.08	Max Load Fillers TC: 101,562.38
fa	11,077.59	10,705.14	31,454.33	10,705.14	11,077.59	Max Load no Fillers TC: 83,668.24
Maximum K L/r	78.33	80.61	47.27	80.61	78.33	TC OAL/Ryy: 574.3270
Fcr	31,227.56	30,440.78	41,080.29	30,440.78	31,227.56	BC Stress: 31,100.56
Fa	28,104.80	27,396.71	36,972.26	27,396.71	28,104.80	BC L/Rz: 189.6082
F'e	46,648.40	44,042.44	140,441.45	44,042.44	46,648.40	TC Shear Stress: 14,368.33
Cm	0.9208	0.9190	0.9005	0.9190	0.9208	BC Shear Stress: 12,793.86
Panel Point Moment	27548.11	26424.15	12516.55	26424.15	27548.11	
Mid Panel Moment	19137.01	11224.11	6819.73	11224.11	19137.01	
Panel Point fb	23885.28	22910.77	10852.34	22910.77	23885.28	
Mid Panel fb	6478.19	3799.55	2308.59	3799.55	6478.19	
Fillers	1	1	4	1	1	
Panel Point Stress	34,962.87	33,615.91	42,306.67	33,615.91	34,962.87	
Mid Panel Stress	0.5607	0.4890	0.9076	0.4890	0.5607	

Web Design

Member	Web Tension	Allow Tension	Web Comp	Allow Comp	Weld	Qty	Material
W2	37,951.94	74,296.57	18,187.67	19,789.00	9.09 x 0.188	2	20 = 2 x 2 x .216
W3	11,188.69	56,851.68	23,358.43	26,805.78	6.43 x 0.163	2	17 = 2 x 2 x .163
W4	19,393.73	33,914.79	9,226.55	9,456.29	6.70 x 0.130	2	09A = 1 1/2 x 1 1/2 x .130
W5	7,549.00	43,636.64	15,901.97	16,588.18	4.99 x 0.143	2	14 = 1 3/4 x 1 3/4 x .143
W6	12,512.30	28,425.84	5,871.44	6,281.03	3.45 x 0.163	1	17 = 2 x 2 x .163
W7	4,193.89	42,291.04	9,020.54	9,159.93	2.16 x 0.188	1	22 = 2 x 2 x .248
W8	7,543.65	36,889.49	3,623.78	4,412.97	2.00 x 0.188	1	C38 = 1.125 x 1.844 x .200
W9	3,623.78	37,148.29	7,543.65	8,096.99	2.00 x 0.188	1	20 = 2 x 2 x .216
V1	1,657.41	21,718.85	4,414.39	4,514.72	2.00 x 0.150	1	C28 = 1.125 x 1.347 x .150
V2	1,189.42	16,459.83	3,485.49	3,837.32	2.00 x 0.134	1	C22 = 1.125 x 1.086 x .134

* Symmetrical Joist

STRESS ANALYSIS - PAGE 3



NEW MILLENNIUM
BUILDING SYSTEMS

Job Number: 8010-0704	Job Name: 10-123 BARRHAVEN FIRE STATION - SHOPORDERS	Date Run: 11/19/2010 3:57:18 PM
Location: OTTAWA, ON	Joist Description: Deep Long Span 58DLH515/235	Mark: TJ40

TCX Design

TCX Left		TCX Right	
TCX Length	0-0 1/2	TCX Length	0-5 1/2
TCX Type	R	TCX Type	R
TCX Depth	7	TCX Depth	7
BPL Length	0-6	BPL Length	0-6
Clear Bearing	0-11 1/4	Clear Bearing	1-1 3/8
BPL Material: 69L = 2 x 3 x .250		BPL Material: 69L = 2 x 3 x .250	
Total Load	515.00	Total Load	515.00
Reqd TL Def L/80	0.01	Reqd TL Def L/80	0.07
Live Load	352.50	Live Load	352.50
Reqd LL Def L/120	0.00	Reqd LL Def L/120	0.05
Section Modulus	1.1534	Section Modulus	1.1534
Reqd SM	0.0001	Reqd SM	0.0153
Mom of Inertia	2.4885	Mom of Inertia	2.4885
Reqd MI	0.0000	Reqd MI	0.0017
Seat Type: T-Plate		Seat Type: T-Plate	

LSD Design

- | | |
|--|--|
| Case 1a: DL | Case 6a: 1.25(DL)+0.5(CL+SL)+1.4(WL+AX)+0.8(TL) |
| Case 1b: 1.4(DL) | Case 6b: 1.25(DL)+0.5(CL+SL)+1.4(WL-AX)+0.8(TL) |
| Case 2a: LL | Case 6c: 1.25(DL)+0.5(CL+SL)+1.4(WL+AX+IP)+0.8(TL) |
| Case 2b: SL | Case 6d: 1.25(DL)+0.5(CL+SL)+1.4(WL-AX+IP)+0.8(TL) |
| Case 3a: 1.25(DL+CL)+1.5(TL+LL) | Case 7a: 1.25(DL+CL)+0.4(WL+AX)+1.5(TL+LL) |
| Case 3b: 1.25(DL+CL)+1.5(TL+SL) | Case 7b: 1.25(DL+CL)+0.4(WL-AX)+1.5(TL+LL) |
| Case 3c: 1.25(DL+CL)+1.5(TL+LL+FEM) | Case 7c: 1.25(DL+CL)+0.4(WL+AX+IP)+1.5(TL+LL) |
| Case 3d: 1.25(DL+CL)+1.5(TL+SL+FEM) | Case 7d: 1.25(DL+CL)+0.4(WL-AX+IP)+1.5(TL+LL) |
| Case 3e: DL+CL+TL+LL | Case 8a: 1.25(DL+CL)+0.4(WL+AX)+1.5(TL+SL) |
| Case 3f: DL+CL+TL+SL | Case 8b: 1.25(DL+CL)+0.4(WL-AX)+1.5(TL+SL) |
| Case 4a: 1.25(DL)+0.5(CL+LL)+1.4(WL+AX)+0.8(TL) | Case 8c: 1.25(DL+CL)+0.4(WL+AX+IP)+1.5(TL+SL) |
| Case 4b: 1.25(DL)+0.5(CL+LL)+1.4(WL-AX)+0.8(TL) | Case 8d: 1.25(DL+CL)+0.4(WL-AX+IP)+1.5(TL+SL) |
| Case 4c: 1.25(DL)+0.5(CL+LL)+1.4(WL+AX+IP)+0.8(TL) | Case 9a: DL+CL+0.5(LL)+0.7(TL)+SM+AX+FEM |
| Case 4d: 1.25(DL)+0.5(CL+LL)+1.4(WL-AX+IP)+0.8(TL) | Case 9b: DL+CL+0.5(LL)+0.7(TL)+SM-AX+FEM |
| Case 4e: 1.25(DL+CL)+1.4(WL+AX)+1.1(TL)+LL | Case 9c: DL+CL+0.25(SL)+0.7(TL)+SM+AX+FEM |
| Case 4f: 1.25(DL+CL)+1.4(WL-AX)+1.1(TL)+LL | Case 9d: DL+CL+0.25(SL)+0.7(TL)+SM-AX+FEM |
| Case 5a: 0.9(DL)+1.4(WL+AX) | Case 9e: DL+CL+LL+1.1(TL)+SM+AX+FEM |
| Case 5b: 0.9(DL)+1.4(WL-AX) | Case 9f: DL+CL+LL+1.1(TL)+SM-AX+FEM |
| Case 5c: 0.9(DL)+1.4(WL+AX+IP) | Case 10a: DL+SM+AX |
| Case 5d: 0.9(DL)+1.4(WL-AX+IP) | Case 10b: DL+SM-AX |
| Case 5e: DL+SM+AX | Case 10c: DL+CL+SM+AX |
| Case 5f: DL+SM-AX | Case 10d: DL+CL+SM-AX |

STRESS ANALYSIS - PAGE 1



NEW MILLENNIUM
BUILDING SYSTEMS

Job Number: 8010-0704	Job Name: 10-123 BARRHAVEN FIRE STATION - SHOPORDERS	Date Run: 11/19/2010 3:57:19 PM
Location: OTTAWA, ON		Joist Description: Deep Long Span 58DLH515/235
		Mark: TJ41

Geometry

Base Length: 80-11 3/4	Working Length: 80-7 3/4	Joist Depth: 58.00	Effective Depth: 56.29	BC Panel Length: 7 @ 9-4	Shape: Parallel Chords
----------------------------------	------------------------------------	------------------------------	----------------------------------	------------------------------------	----------------------------------

Variable	Left End	Right End
BC Panel	7-9 7/8	7-9 7/8
TC Panel	6-2 7/8	6-2 7/8
First Half	4-8	4-8
First Diag.	12-5 7/8	12-5 7/8
Depth	58.00	58.00

Deflection Case 2a: LL (Max Deflection: -1.75 in-Y, -0.29 in-X)

Loads, *** All loads are factored ***

Load Type	Category	Load1	Load2	Position	Direction	Loc/Begin	Sp/End
Uniform (plf)	DL	162.50	162.50	TC	+	0-0	80-11 3/4
Uniform (plf)	LL	352.50	352.50	TC	+	0-0	80-11 3/4
Conc anywhere (lbs)	TL	315.00	0.00	BC	+	40-5 7/8	0-0
Conc anywhere (lbs)	TL	315.00	0.00	TC	+	40-5 7/8	0-0
Net Uplift (plf)	WL	250.00	250.00	TC	-	0-0	80-11 3/4
Conc Load (lbs)	TL	1,700.00	0.00	TC	+	19-6 1/2	25-6 1/2
Conc Load (lbs)	TL	1,700.00	0.00	TC	+	26-6 1/2	32-6 1/2
Conc Load (lbs)	TL	1,700.00	0.00	TC	+	48-6 1/2	54-6 1/2
Conc Load (lbs)	TL	1,700.00	0.00	TC	+	54-6 1/2	60-6 1/2

Stress Analysis Summary

Int. Panel TC: 56.00	Max Panel BC: 112.00	Reaction LE: 25,060.93	Reaction RE: 25,011.53	Minimum Shear: 6,265.23	Max TC Comp.: 111,537.45	Max BC Tension: 112,872.95
--------------------------------	--------------------------------	----------------------------------	----------------------------------	-----------------------------------	------------------------------------	--------------------------------------

Member	TC Tension	TC Compression	BC Tension	BC Compression	Web Tension	Web Comp.	Web Length	PP Dist.
W2	15,510.43	37,430.81	0.00	0.00	44,975.61	18,190.32	107.75	0-2
V1S	14,980.38	36,359.80	0.00	0.00	1,657.44	8,389.80	59.41	6-2 7/8
W3	14,980.38	36,359.80	56,018.12	22,872.12	11,189.81	28,532.62	79.40	7-9 7/8
W4	29,379.90	72,880.01	56,018.12	22,872.12	24,567.53	9,227.47	79.40	12-5 7/8
W5	29,379.90	72,880.01	87,351.04	34,704.44	7,549.75	21,000.94	79.40	17-1 7/8
W6	38,845.75	99,225.11	87,351.04	34,704.44	17,610.94	5,872.03	79.40	21-9 7/8
V3	38,845.75	99,225.11	87,351.04	34,704.44	1,189.42	4,315.71	56.29	26-5 7/8
W7	38,845.75	99,225.11	107,190.11	41,803.84	4,194.31	12,232.55	79.40	26-5 7/8
W8	43,578.68	111,537.45	107,190.11	41,803.84	8,842.54	3,624.14	79.40	31-1 7/8
V4	43,578.68	111,537.45	107,190.11	41,803.84	1,189.42	3,591.02	56.29	35-9 7/8
W9	43,578.68	111,537.45	112,872.95	44,170.30	3,624.14	8,837.37	79.40	35-9 7/8

* Symmetrical Joist

Standard Verticals

Member	Position	Max Tension	Max Comp.	Length
V2	Interior	2,067.50	5,291.02	56.29

STRESS ANALYSIS - PAGE 2



Job Number: 8010-0704	Job Name: 10-123 BARRHAVEN FIRE STATION - SHOPORDERS	Date Run: 11/19/2010 3:57:19 PM
Location: OTTAWA, ON		Joist Description: Deep Long Span 58DLH515/235
		Mark: TJ41

Chord Properties

Chord	Area	Rx	Rz	Ryy	Y	Ix	Q	Material
TC	1.6070	0.9260	0.5907	1.6920	0.8536	1.3780	1.0000	34 = 3 x 3 x .281
BC	1.6070	0.9260	0.5907	1.6920	0.8536	1.3780	1.0000	34 = 3 x 3 x .281

Axial and Bending Analysis

K: 0.75	Fy: 50,000.00	Fb: 45,000.00	Mom of Inertia: 5,095.25	LL 360: 362.93	LL 240: 544.39	Max Bridg TC: 23-11 5/8	Max Bridg BC: 17-1 1/4
-------------------	-------------------------	-------------------------	------------------------------------	--------------------------	--------------------------	-----------------------------------	----------------------------------

Top Chord Check	End Panel LE	First Panel LE	Interior Panel	First Panel RE	End Panel RE	
Length	72.88	75.00	56.00	75.00	72.88	Gap Between Chords: 1.1250
Bending Load	499.74	499.74	499.74	499.74	499.74	Min Weld Len 2X: 0.8012
Axial Load	37,430.81	36,359.80	111,537.45	36,305.32	37,376.33	Max Load Fillers TC: 118,132.91
fa	11,645.89	11,312.67	34,702.79	11,295.72	11,628.94	Max Load no Fillers TC: 96,436.74
Maximum K L/r	78.70	80.99	47.40	80.99	78.70	TC OAL/Ryy: 571.9450
Fcr	31,791.03	30,950.52	42,424.75	30,950.52	31,791.03	BC Stress: 37,662.29
Fa	28,611.92	27,855.47	38,182.27	27,855.47	28,611.92	BC L/Rz: 189.6082
F'e	46,214.04	43,632.34	139,133.72	43,632.34	46,214.04	TC Shear Stress: 15,159.85
Cm	0.9160	0.9136	0.8891	0.9137	0.9161	BC Shear Stress: 15,159.85
Panel Point Moment	27548.11	26424.15	12516.55	26424.15	27548.11	
Mid Panel Moment	19137.01	11224.11	6819.73	11224.11	19137.01	
Panel Point fb	21453.73	20578.42	9747.56	20578.42	21453.73	
Mid Panel fb	5927.39	3476.50	2112.31	3476.50	5927.39	
Fillers	1	1	8	1	1	
Panel Point Stress	33,099.62	31,891.09	44,450.34	31,874.14	33,082.67	
Mid Panel Stress	0.5560	0.4942	0.9602	0.4936	0.5553	

Web Design

Member	Web Tension	Allow Tension	Web Comp	Allow Comp	Weld	Qty	Material
W2	44,975.61	74,296.57	18,190.32	19,791.16	10.77 x 0.188	2	20 = 2 x 2 x .216
W3	11,189.81	65,039.63	28,532.62	29,498.59	6.85 x 0.187	2	A36 = 2.0938 x .187
W4	24,567.53	33,914.79	9,227.47	9,458.19	8.48 x 0.130	2	09A = 1 1/2 x 1 1/2 x .130
W5	7,549.75	56,851.68	21,000.94	26,809.57	5.78 x 0.163	2	17 = 2 x 2 x .163
W6	17,610.94	28,425.84	5,872.03	6,282.29	4.85 x 0.163	1	17 = 2 x 2 x .163
W7	4,194.31	43,636.64	12,232.55	16,591.25	3.84 x 0.143	2	14 = 1 3/4 x 1 3/4 x .143
W8	8,842.54	36,889.49	3,624.14	4,413.76	2.12 x 0.188	1	C38 = 1.125 x 1.844 x .200
W9	3,624.14	42,291.04	8,837.37	9,161.77	2.12 x 0.188	1	22 = 2 x 2 x .248
V1	1,657.44	28,425.84	8,389.80	11,166.98	2.31 x 0.163	1	17 = 2 x 2 x .163
V2	2,067.50	16,459.83	5,291.02	3,838.63	2.00 x 0.134	1	C22 = 1.125 x 1.086 x .134

* Symmetrical Joist

STRESS ANALYSIS - PAGE 3



NEW MILLENNIUM
BUILDING SYSTEMS

Job Number: 8010-0704	Job Name: 10-123 BARRHAVEN FIRE STATION - SHOPORDERS	Date Run: 11/19/2010 3:57:19 PM
Location: OTTAWA, ON	Joist Description: Deep Long Span 58DLH515/235	Mark: TJ41

TCX Design

TCX Left		TCX Right	
TCX Length	0-5 1/2	TCX Length	0-0 1/2
TCX Type	R	TCX Type	R
TCX Depth	7	TCX Depth	7
BPL Length	0-6	BPL Length	0-6
Clear Bearing	1-4	Clear Bearing	0-8 1/4
BPL Material: 69L = 2 x 3 x .250		BPL Material: 69L = 2 x 3 x .250	
Total Load	515.00	Total Load	515.00
Reqd TL Def L/80	0.07	Reqd TL Def L/80	0.01
Live Load	352.50	Live Load	352.50
Reqd LL Def L/120	0.05	Reqd LL Def L/120	0.00
Section Modulus	1.2841	Section Modulus	1.2841
Reqd SM	0.0153	Reqd SM	0.0001
Mom of Inertia	2.7561	Mom of Inertia	2.7561
Reqd MI	0.0017	Reqd MI	0.0000
Seat Type: T-Plate		Seat Type: T-Plate	

LSD Design

- | | |
|--|--|
| Case 1a: DL | Case 6a: 1.25(DL)+0.5(CL+SL)+1.4(WL+AX)+0.8(TL) |
| Case 1b: 1.4(DL) | Case 6b: 1.25(DL)+0.5(CL+SL)+1.4(WL-AX)+0.8(TL) |
| Case 2a: LL | Case 6c: 1.25(DL)+0.5(CL+SL)+1.4(WL+AX+IP)+0.8(TL) |
| Case 2b: SL | Case 6d: 1.25(DL)+0.5(CL+SL)+1.4(WL-AX+IP)+0.8(TL) |
| Case 3a: 1.25(DL+CL)+1.5(TL+LL) | Case 7a: 1.25(DL+CL)+0.4(WL+AX)+1.5(TL+LL) |
| Case 3b: 1.25(DL+CL)+1.5(TL+SL) | Case 7b: 1.25(DL+CL)+0.4(WL-AX)+1.5(TL+LL) |
| Case 3c: 1.25(DL+CL)+1.5(TL+LL+FEM) | Case 7c: 1.25(DL+CL)+0.4(WL+AX+IP)+1.5(TL+LL) |
| Case 3d: 1.25(DL+CL)+1.5(TL+SL+FEM) | Case 7d: 1.25(DL+CL)+0.4(WL-AX+IP)+1.5(TL+LL) |
| Case 3e: DL+CL+TL+LL | Case 8a: 1.25(DL+CL)+0.4(WL+AX)+1.5(TL+SL) |
| Case 3f: DL+CL+TL+SL | Case 8b: 1.25(DL+CL)+0.4(WL-AX)+1.5(TL+SL) |
| Case 4a: 1.25(DL)+0.5(CL+LL)+1.4(WL+AX)+0.8(TL) | Case 8c: 1.25(DL+CL)+0.4(WL+AX+IP)+1.5(TL+SL) |
| Case 4b: 1.25(DL)+0.5(CL+LL)+1.4(WL-AX)+0.8(TL) | Case 8d: 1.25(DL+CL)+0.4(WL-AX+IP)+1.5(TL+SL) |
| Case 4c: 1.25(DL)+0.5(CL+LL)+1.4(WL+AX+IP)+0.8(TL) | Case 9a: DL+CL+0.5(LL)+0.7(TL)+SM+AX+FEM |
| Case 4d: 1.25(DL)+0.5(CL+LL)+1.4(WL-AX+IP)+0.8(TL) | Case 9b: DL+CL+0.5(LL)+0.7(TL)+SM-AX+FEM |
| Case 4e: 1.25(DL+CL)+1.4(WL+AX)+1.1(TL)+LL | Case 9c: DL+CL+0.25(SL)+0.7(TL)+SM+AX+FEM |
| Case 4f: 1.25(DL+CL)+1.4(WL-AX)+1.1(TL)+LL | Case 9d: DL+CL+0.25(SL)+0.7(TL)+SM-AX+FEM |
| Case 5a: 0.9(DL)+1.4(WL+AX) | Case 9e: DL+CL+LL+1.1(TL)+SM+AX+FEM |
| Case 5b: 0.9(DL)+1.4(WL-AX) | Case 9f: DL+CL+LL+1.1(TL)+SM-AX+FEM |
| Case 5c: 0.9(DL)+1.4(WL+AX+IP) | Case 10a: DL+SM+AX |
| Case 5d: 0.9(DL)+1.4(WL-AX+IP) | Case 10b: DL+SM-AX |
| Case 5e: DL+SM+AX | Case 10c: DL+CL+SM+AX |
| Case 5f: DL+SM-AX | Case 10d: DL+CL+SM-AX |

STRESS ANALYSIS - PAGE 1



NEW MILLENNIUM
BUILDING SYSTEMS

Job Number: 8010-0704	Job Name: 10-123 BARRHAVEN FIRE STATION - SHOPORDERS	Date Run: 11/19/2010 3:57:20 PM
Location: OTTAWA, ON	Joist Description: Deep Long Span 58DLH609/277	Mark: TJ43

Geometry

Base Length: 80-11 3/4	Working Length: 80-7 3/4	Joist Depth: 58.00	Effective Depth: 56.28	BC Panel Length: 7 @ 9-4	Shape: Parallel Chords
----------------------------------	------------------------------------	------------------------------	----------------------------------	------------------------------------	----------------------------------

Variable	Left End	Right End	Deflection Case 2a: LL (Max Deflection: -2.26 in-Y, -0.36 in-X)
BC Panel	7-9 7/8	7-9 7/8	
TC Panel	6-2 7/8	6-2 7/8	
First Half	4-8	4-8	
First Diag.	12-5 7/8	12-5 7/8	
Depth	58.00	58.00	

Loads, *** All loads are factored ***

Load Type	Category	Load1	Load2	Position	Direction	Loc/Begin	Sp/End
Uniform (plf)	DL	193.50	193.50	TC	+	0-0	80-11 3/4
Uniform (plf)	LL	415.50	415.50	TC	+	0-0	80-11 3/4
Conc anywhere (lbs)	TL	315.00	0.00	BC	+	40-5 7/8	0-0
Conc anywhere (lbs)	TL	315.00	0.00	TC	+	40-5 7/8	0-0
Net Uplift (plf)	WL	250.00	250.00	TC	-	0-0	80-11 3/4
Uniform (plf)	LL	188.00	188.00	TC	+	52-6 1/2	81-5 1/4
Conc Load (lbs)	LL	1,700.00	0.00	TC	+	72-11 1/2	78-11 1/2

Stress Analysis Summary

Int. Panel TC: 56.00	Max Panel BC: 112.00	Reaction LE: 26,470.51	Reaction RE: 31,544.42	Minimum Shear: 7,886.10	Max TC Comp.: 118,869.16	Max BC Tension 119,161.26
--------------------------------	--------------------------------	----------------------------------	----------------------------------	-----------------------------------	------------------------------------	-------------------------------------

Member	TC Tension	TC Compression	BC Tension	BC Compression	Web Tension	Web Comp.	Web Length	PP Dist.
W2	15,570.22	46,838.83	0.00	0.00	55,754.92	18,259.43	107.74	0-2
V1S	15,038.14	44,770.69	0.00	0.00	1,663.52	8,046.17	59.40	6-2 7/8
W3	15,038.14	44,770.69	67,224.48	22,960.30	11,231.79	31,834.27	79.39	7-9 7/8
W4	29,493.17	84,867.63	67,224.48	22,960.30	25,553.82	9,262.09	79.39	12-5 7/8
W5	29,493.17	84,867.63	98,810.02	34,838.24	7,578.07	20,503.74	79.39	17-1 7/8
W6	38,995.51	109,051.67	98,810.02	34,838.24	16,494.57	5,894.06	79.39	21-9 7/8
V3	38,995.51	109,051.67	98,810.02	34,838.24	1,193.76	4,066.34	56.28	26-5 7/8
W7	38,995.51	109,051.67	115,592.55	41,965.00	4,210.04	12,383.28	79.39	26-5 7/8
W8	43,746.70	118,869.16	115,592.55	41,965.00	11,124.82	3,637.74	79.39	31-1 7/8
V4	43,746.70	118,869.16	115,592.55	41,965.00	1,193.76	4,066.35	56.28	35-9 7/8
W9	43,746.70	118,869.16	119,161.26	44,340.59	5,523.00	11,124.82	79.39	35-9 7/8

* Symmetrical Joist

Standard Verticals

Member	Position	Max Tension	Max Comp.	Length
V2	Interior	1,193.76	4,943.68	56.28

STRESS ANALYSIS - PAGE 2



NEW MILLENNIUM
BUILDING SYSTEMS

Job Number: 8010-0704	Job Name: 10-123 BARRHAVEN FIRE STATION - SHOPORDERS	Date Run: 11/19/2010 3:57:20 PM
Location: OTTAWA, ON		Joist Description: Deep Long Span 58DLH609/277
		Mark: TJ43

Chord Properties

Chord	Area	Rx	Rz	Ryy	Y	Ix	Q	Material
TC	1.7800	0.9216	0.5891	1.6993	0.8652	1.5119	1.0000	35 = 3 x 3 x .313
BC	1.6070	0.9260	0.5907	1.6920	0.8536	1.3780	1.0000	34 = 3 x 3 x .281

Axial and Bending Analysis

K: 0.75	Fy: 50,000.00	Fb: 45,000.00	Mom of Inertia: 5,353.28	LL 360: 381.31	LL 240: 571.96	Max Bridg TC: 24-0 7/8	Max Bridg BC: 17-0 3/4
-------------------	-------------------------	-------------------------	------------------------------------	--------------------------	--------------------------	----------------------------------	----------------------------------

Top Chord Check	End Panel LE	First Panel LE	Interior Panel	First Panel RE	End Panel RE	
Length	72.88	75.00	56.00	75.00	72.88	Gap Between Chords: 1.1250
Bending Load	591.09	591.09	591.09	767.34	767.34	Min Weld Len 2X: 0.8539
Axial Load	39,680.13	38,413.38	118,869.16	44,770.69	46,838.83	Max Load Fillers TC: 130,269.35
fa	11,145.91	10,790.09	33,389.63	12,575.82	13,156.75	Max Load no Fillers TC: 106,248.91
Maximum K L/r	79.07	81.38	47.53	81.38	79.07	TC OAL/Ryy: 569.4848
Fcr	31,653.68	30,808.92	42,388.11	30,808.92	31,653.68	BC Stress: 39,618.78
Fa	28,488.31	27,728.02	38,149.30	27,728.02	28,488.31	BC L/Rz: 189.6082
F'e	45,776.38	43,219.13	137,816.09	43,219.13	45,776.38	TC Shear Stress: 16,884.62
Cm	0.9188	0.9168	0.8923	0.9030	0.9042	BC Shear Stress: 18,791.01
Panel Point Moment	32079.27	30956.00	14506.04	39699.31	40821.25	
Mid Panel Moment	22179.10	13023.99	7814.48	16496.51	28048.22	
Panel Point fb	22647.42	21854.42	10241.02	28027.05	28819.12	
Mid Panel fb	6346.19	3726.60	2235.99	4720.21	8025.54	
Fillers	1	1	6	1	1	
Panel Point Stress	33,793.33	32,644.51	43,630.66	40,602.87	41,975.87	
Mid Panel Stress	0.5491	0.4825	0.9292	0.5780	0.6724	

Web Design

Member	Web Tension	Allow Tension	Web Comp	Allow Comp	Weld	Qty	Material
W2	55,754.92	74,296.57	18,259.43	19,793.38	13.35 x 0.188	2	20 = 2 x 2 x .216
W3	11,231.79	74,296.57	31,834.27	35,159.32	7.62 x 0.188	2	20 = 2 x 2 x .216
W4	25,553.82	33,914.79	9,262.09	9,460.14	8.83 x 0.130	2	09A = 1 1/2 x 1 1/2 x .130
W5	7,578.07	56,851.68	20,503.74	26,813.47	5.65 x 0.163	2	17 = 2 x 2 x .163
W6	16,494.57	28,425.84	5,894.06	6,283.59	4.54 x 0.163	1	17 = 2 x 2 x .163
W7	4,210.04	43,636.64	12,383.28	16,594.40	3.89 x 0.143	2	14 = 1 3/4 x 1 3/4 x .143
W8	11,124.82	36,889.49	3,637.74	4,414.57	2.66 x 0.188	1	C38 = 1.125 x 1.844 x .200
W9	5,523.00	43,636.64	11,124.82	16,594.40	3.49 x 0.143	2	14 = 1 3/4 x 1 3/4 x .143
V1	1,663.52	28,425.84	8,046.17	11,170.63	2.22 x 0.163	1	17 = 2 x 2 x .163
V2	1,193.76	21,718.85	4,943.68	4,937.85	2.00 x 0.150	1	C28 = 1.125 x 1.347 x .150

* Symmetrical Joist

STRESS ANALYSIS - PAGE 3



NEW MILLENNIUM
BUILDING SYSTEMS

Job Number: 8010-0704	Job Name: 10-123 BARRHAVEN FIRE STATION - SHOPORDERS	Date Run: 11/19/2010 3:57:20 PM
Location: OTTAWA, ON	Joist Description: Deep Long Span 58DLH609/277	Mark: TJ43

TCX Design

TCX Left		TCX Right	
TCX Length	0-0 1/2	TCX Length	0-5 1/2
TCX Type	R	TCX Type	R
TCX Depth	7	TCX Depth	7
BPL Length	0-6	BPL Length	0-6
Clear Bearing	0-11	Clear Bearing	1-1 1/4
BPL Material: 69L = 2 x 3 x .250		BPL Material: 69L = 2 x 3 x .250	

Total Load	609.00	Total Load	609.00
Reqd TL Def L/80	0.01	Reqd TL Def L/80	0.07
Live Load	415.50	Live Load	415.50
Reqd LL Def L/120	0.00	Reqd LL Def L/120	0.05
Section Modulus	1.4165	Section Modulus	1.4165
Reqd SM	0.0001	Reqd SM	0.0181
Mom of Inertia	3.0238	Mom of Inertia	3.0238
Reqd MI	0.0000	Reqd MI	0.0021

Seat Type: T-Plate

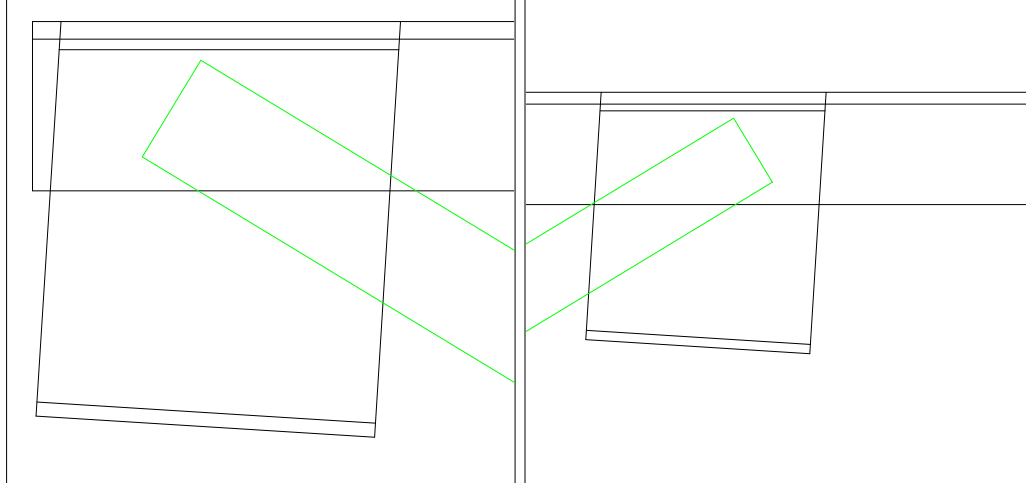

LSD Design

- | | |
|--|--|
| Case 1a: DL | Case 6a: 1.25(DL)+0.5(CL+SL)+1.4(WL+AX)+0.8(TL) |
| Case 1b: 1.4(DL) | Case 6b: 1.25(DL)+0.5(CL+SL)+1.4(WL-AX)+0.8(TL) |
| Case 2a: LL | Case 6c: 1.25(DL)+0.5(CL+SL)+1.4(WL+AX+IP)+0.8(TL) |
| Case 2b: SL | Case 6d: 1.25(DL)+0.5(CL+SL)+1.4(WL-AX+IP)+0.8(TL) |
| Case 3a: 1.25(DL+CL)+1.5(TL+LL) | Case 7a: 1.25(DL+CL)+0.4(WL+AX)+1.5(TL+LL) |
| Case 3b: 1.25(DL+CL)+1.5(TL+SL) | Case 7b: 1.25(DL+CL)+0.4(WL-AX)+1.5(TL+LL) |
| Case 3c: 1.25(DL+CL)+1.5(TL+LL+FEM) | Case 7c: 1.25(DL+CL)+0.4(WL+AX+IP)+1.5(TL+LL) |
| Case 3d: 1.25(DL+CL)+1.5(TL+SL+FEM) | Case 7d: 1.25(DL+CL)+0.4(WL-AX+IP)+1.5(TL+LL) |
| Case 3e: DL+CL+TL+LL | Case 8a: 1.25(DL+CL)+0.4(WL+AX)+1.5(TL+SL) |
| Case 3f: DL+CL+TL+SL | Case 8b: 1.25(DL+CL)+0.4(WL-AX)+1.5(TL+SL) |
| Case 4a: 1.25(DL)+0.5(CL+LL)+1.4(WL+AX)+0.8(TL) | Case 8c: 1.25(DL+CL)+0.4(WL+AX+IP)+1.5(TL+SL) |
| Case 4b: 1.25(DL)+0.5(CL+LL)+1.4(WL-AX)+0.8(TL) | Case 8d: 1.25(DL+CL)+0.4(WL-AX+IP)+1.5(TL+SL) |
| Case 4c: 1.25(DL)+0.5(CL+LL)+1.4(WL+AX+IP)+0.8(TL) | Case 9a: DL+CL+0.5(LL)+0.7(TL)+SM+AX+FEM |
| Case 4d: 1.25(DL)+0.5(CL+LL)+1.4(WL-AX+IP)+0.8(TL) | Case 9b: DL+CL+0.5(LL)+0.7(TL)+SM-AX+FEM |
| Case 4e: 1.25(DL+CL)+1.4(WL+AX)+1.1(TL)+LL | Case 9c: DL+CL+0.25(SL)+0.7(TL)+SM+AX+FEM |
| Case 4f: 1.25(DL+CL)+1.4(WL-AX)+1.1(TL)+LL | Case 9d: DL+CL+0.25(SL)+0.7(TL)+SM-AX+FEM |
| Case 5a: 0.9(DL)+1.4(WL+AX) | Case 9e: DL+CL+LL+1.1(TL)+SM+AX+FEM |
| Case 5b: 0.9(DL)+1.4(WL-AX) | Case 9f: DL+CL+LL+1.1(TL)+SM-AX+FEM |
| Case 5c: 0.9(DL)+1.4(WL+AX+IP) | Case 10a: DL+SM+AX |
| Case 5d: 0.9(DL)+1.4(WL-AX+IP) | Case 10b: DL+SM-AX |
| Case 5e: DL+SM+AX | Case 10c: DL+CL+SM+AX |
| Case 5f: DL+SM-AX | Case 10d: DL+CL+SM-AX |

STRESS ANALYSIS - PAGE 1



NEW MILLENNIUM
BUILDING SYSTEMS

Job Number: 8010-0704	Job Name: 10-123 BARRHAVEN FIRE STATION - SHOPORDERS	Date Run: 11/19/2010 4:20:54 PM
Location: OTTAWA, ON	Joist Description: Deep Long Span 58DLH515/235	Mark: TJ45

Geometry

Base Length: 80-11 3/4	Working Length: 80-7 3/4	Joist Depth: 58.00	Effective Depth: 54.88	BC Panel Length: 7 @ 9-4	Shape: Parallel Chords
----------------------------------	------------------------------------	------------------------------	----------------------------------	------------------------------------	----------------------------------

Variable	Left End	Right End	Deflection Case 2a: LL (Max Deflection: -1.53 in-Y, -0.18 in-X)
BC Panel	7-9 7/8	7-9 7/8	
TC Panel	6-2 7/8	6-2 7/8	
First Half	4-8	4-8	
First Diag.	12-5 7/8	12-5 7/8	
Depth	58.00	58.00	

Loads, *** All loads are factored ***

Load Type	Category	Load1	Load2	Position	Direction	Loc/Begin	Sp/End
Uniform (plf)	DL	162.50	162.50	TC	+	0-0	80-11 3/4
Uniform (plf)	LL	352.50	352.50	TC	+	0-0	80-11 3/4
Net Uplift (plf)	WL	250.00	250.00	TC	-	0-0	80-11 3/4
Conc Load (lbs)	LL	3,375.00	0.00	TC	+	6-11	6-11
Conc Load (lbs)	LL	3,375.00	0.00	TC	+	22-5	22-5
Conc Load (lbs)	LL	3,375.00	0.00	TC	+	25-3 1/2	25-3 1/2
Conc anywhere (lbs)	TL	315.00	0.00	BC	+	40-5 7/8	0-0
Conc anywhere (lbs)	TL	315.00	0.00	TC	+	40-5 7/8	0-0
Conc Load (lbs)	LL	3,375.00	0.00	TC	+	40-9 1/4	40-9 1/4
Conc Load (lbs)	LL	3,375.00	0.00	TC	+	43-8	43-8
Uniform (plf)	LL	338.00	338.00	TC	+	52-1 1/2	81-0 1/4
Conc Load (lbs)	LL	3,375.00	0.00	TC	+	59-1 7/8	59-1 7/8

Stress Analysis Summary

Int. Panel TC: 56.00	Max Panel BC: 112.00	Reaction LE: 35,401.35	Reaction RE: 38,109.87	Minimum Shear: 9,527.47	Max TC Comp.: 166,589.80	Max BC Tension: 168,349.03
--------------------------------	--------------------------------	----------------------------------	----------------------------------	-----------------------------------	------------------------------------	--------------------------------------

Member	TC Tension	TC Compression	BC Tension	BC Compression	Web Tension	Web Comp.	Web Length	PP Dist.
W2	15,909.40	58,938.75	0.00	0.00	69,263.84	18,531.68	107.02	0-2
V1S	15,365.72	57,119.20	0.00	0.00	1,661.85	7,988.36	58.08	6-2 7/8
W3	15,365.72	57,119.20	87,680.86	23,460.45	11,333.89	43,101.38	78.41	7-9 7/8
W4	30,135.63	113,491.66	87,680.86	23,460.45	36,449.39	9,346.28	78.41	12-5 7/8
W5	30,135.63	113,491.66	135,240.61	35,597.14	7,646.96	31,298.32	78.41	17-1 7/8
W6	39,844.98	149,483.92	135,240.61	35,597.14	22,418.53	5,947.64	78.41	21-9 7/8
V3	39,844.98	149,483.92	135,240.61	35,597.14	1,189.42	6,804.34	54.88	26-5 7/8
W7	39,844.98	149,483.92	159,665.41	42,879.15	4,248.31	14,683.84	78.41	26-5 7/8
W8	44,699.65	166,589.80	159,665.41	42,879.15	13,611.93	3,670.81	78.41	31-1 7/8
V4	44,699.65	166,589.80	159,665.41	42,879.15	1,189.42	3,866.28	54.88	35-9 7/8
W9	44,699.65	166,589.80	168,349.03	45,306.49	3,670.81	13,611.93	78.41	35-9 7/8

* Symmetrical Joist

Standard Verticals

Member	Position	Max Tension	Max Comp.	Length
V2	Interior	1,189.42	6,804.34	54.88

STRESS ANALYSIS - PAGE 2



Job Number: 8010-0704	Job Name: 10-123 BARRHAVEN FIRE STATION - SHOPORDERS	Date Run: 11/19/2010 4:20:54 PM
Location: OTTAWA, ON		Joist Description: Deep Long Span 58DLH515/235
		Mark: TJ45

Chord Properties

Chord	Area	Rx	Rz	Ryy	Y	Ix	Q	Material
TC	5.7500	1.8607	1.1847	2.9176	1.6848	19.9078	0.9613	50 = 6 x 6 x .500
BC	4.7500	1.5390	0.9829	2.5210	1.4342	11.2503	1.0000	47 = 5 x 5 x .500

Axial and Bending Analysis

K: 0.75	Fy: 50,000.00	Fb: 45,000.00	Mom of Inertia: 15,700.34	LL 300: 1,341.98	TL 489: 823.30	Max Bridg TC: 41-4	Max Bridg BC: 45-8 5/8
-------------------	-------------------------	-------------------------	-------------------------------------	----------------------------	--------------------------	------------------------------	----------------------------------

Top Chord Check	End Panel LE	First Panel LE	Interior Panel	First Panel RE	End Panel RE	
Length	72.88	75.00	56.00	75.00	72.88	Gap Between Chords: 1.1250
Bending Load	499.74	499.74	499.74	816.61	816.61	Min Weld Len 2X: 1.1967
Axial Load	56,125.90	53,985.49	166,589.80	57,119.20	58,938.75	Max Load Fillers TC: 484,563.25
fa	4,880.51	4,694.39	14,486.07	4,966.89	5,125.11	Max Load no Fillers TC: 461,365.13
Maximum K L/r	61.51	63.30	35.45	63.30	61.51	TC OAL/Ryy: 331.6915
Fcr	36,841.47	36,266.29	44,001.90	36,266.29	36,841.47	BC Stress: 18,238.64
Fa	33,157.32	32,639.66	39,601.71	32,639.66	33,157.32	BC L/Rz: 113.9466
F'e	186,593.61	176,169.77	561,765.81	176,169.77	186,593.61	TC Shear Stress: 6,459.87
Cm	0.9913	0.9911	0.9885	0.9906	0.9908	BC Shear Stress: 7,762.78
Panel Point Moment	27548.11	26424.15	12516.55	42143.51	43265.08	
Mid Panel Moment	19137.01	11224.11	6819.73	17467.26	29688.93	
Panel Point fb	2985.66	2863.85	1356.54	4567.51	4689.06	
Mid Panel fb	809.77	474.94	288.57	739.12	1256.27	
Fillers	0	0	0	0	0	
Panel Point Stress	7,866.17	7,558.24	15,842.61	9,534.40	9,814.17	
Mid Panel Stress	0.0927	0.0831	0.3718	0.0936	0.1070	

Web Design

Member	Web Tension	Allow Tension	Web Comp	Allow Comp	Weld	Qty	Material
W2	69,263.84	74,296.57	18,531.68	20,062.37	16.58 x 0.188	2	20 = 2 x 2 x .216
W3	11,333.89	92,268.59	43,101.38	57,129.21	10.32 x 0.188	2	25 = 2 1/2 x 2 1/2 x .212
W4	36,449.39	42,291.04	9,346.28	9,395.65	8.73 x 0.188	1	22 = 2 x 2 x .248
W5	7,646.96	74,296.57	31,298.32	35,814.86	7.49 x 0.188	2	20 = 2 x 2 x .216
W6	22,418.53	28,425.84	5,947.64	6,442.66	6.17 x 0.163	1	17 = 2 x 2 x .163
W7	4,248.31	43,636.64	14,683.84	16,975.48	4.61 x 0.143	2	14 = 1 3/4 x 1 3/4 x .143
W8	13,611.93	36,889.49	3,670.81	4,513.32	3.26 x 0.188	1	C38 = 1.125 x 1.844 x .200
W9	3,670.81	43,636.64	13,611.93	16,975.48	4.27 x 0.143	2	14 = 1 3/4 x 1 3/4 x .143
V1	1,661.85	41,419.47	7,988.36	8,240.46	2.00 x 0.188	1	C40 = 1.125 x 2.006 x .209
V2	1,189.42	16,459.83	6,804.34	4,008.67	2.00 x 0.134	1	C22 = 1.125 x 1.086 x .134

* Symmetrical Joist

STRESS ANALYSIS - PAGE 3



<i>Job Number:</i> 8010-0704	<i>Job Name:</i> 10-123 BARRHAVEN FIRE STATION - SHOPORDERS	<i>Date Run:</i> 11/19/2010 4:20:54 PM
<i>Location:</i> OTTAWA, ON	<i>Joist Description:</i> Deep Long Span 58DLH515/235	<i>Mark:</i> TJ45

TCX Design

TCX Left		TCX Right	
TCX Length	0-5 1/2	TCX Length	0-0 1/2
TCX Type	R	TCX Type	R
TCX Depth	7	TCX Depth	7
BPL Length	0-11 1/2	BPL Length	0-6 1/2
Clear Bearing	1-3 3/8	Clear Bearing	0-7 3/4
BPL Material: 50 = 6 x 6 x .500		BPL Material: 50 = 6 x 6 x .500	
Total Load	515.00	Total Load	515.00
Reqd TL Def L/80	0.07	Reqd TL Def L/80	0.01
Live Load	352.50	Live Load	352.50
Reqd LL Def L/120	0.05	Reqd LL Def L/120	0.00
Section Modulus	9.2268	Section Modulus	9.2268
Reqd SM	0.0153	Reqd SM	0.0001
Mom of Inertia	39.8157	Mom of Inertia	39.8157
Reqd MI	0.0017	Reqd MI	0.0000
Seat Type: Lapped		Seat Type: Lapped	

LSD Design

- | | |
|--|--|
| Case 1a: DL | Case 6a: 1.25(DL)+0.5(CL+SL)+1.4(WL+AX)+0.8(TL) |
| Case 1b: 1.4(DL) | Case 6b: 1.25(DL)+0.5(CL+SL)+1.4(WL-AX)+0.8(TL) |
| Case 2a: LL | Case 6c: 1.25(DL)+0.5(CL+SL)+1.4(WL+AX+IP)+0.8(TL) |
| Case 2b: SL | Case 6d: 1.25(DL)+0.5(CL+SL)+1.4(WL-AX+IP)+0.8(TL) |
| Case 3a: 1.25(DL+CL)+1.5(TL+LL) | Case 7a: 1.25(DL+CL)+0.4(WL+AX)+1.5(TL+LL) |
| Case 3b: 1.25(DL+CL)+1.5(TL+SL) | Case 7b: 1.25(DL+CL)+0.4(WL-AX)+1.5(TL+LL) |
| Case 3c: 1.25(DL+CL)+1.5(TL+LL+FEM) | Case 7c: 1.25(DL+CL)+0.4(WL+AX+IP)+1.5(TL+LL) |
| Case 3d: 1.25(DL+CL)+1.5(TL+SL+FEM) | Case 7d: 1.25(DL+CL)+0.4(WL-AX+IP)+1.5(TL+LL) |
| Case 3e: DL+CL+TL+LL | Case 8a: 1.25(DL+CL)+0.4(WL+AX)+1.5(TL+SL) |
| Case 3f: DL+CL+TL+SL | Case 8b: 1.25(DL+CL)+0.4(WL-AX)+1.5(TL+SL) |
| Case 4a: 1.25(DL)+0.5(CL+LL)+1.4(WL+AX)+0.8(TL) | Case 8c: 1.25(DL+CL)+0.4(WL+AX+IP)+1.5(TL+SL) |
| Case 4b: 1.25(DL)+0.5(CL+LL)+1.4(WL-AX)+0.8(TL) | Case 8d: 1.25(DL+CL)+0.4(WL-AX+IP)+1.5(TL+SL) |
| Case 4c: 1.25(DL)+0.5(CL+LL)+1.4(WL+AX+IP)+0.8(TL) | Case 9a: DL+CL+0.5(LL)+0.7(TL)+SM+AX+FEM |
| Case 4d: 1.25(DL)+0.5(CL+LL)+1.4(WL-AX+IP)+0.8(TL) | Case 9b: DL+CL+0.5(LL)+0.7(TL)+SM-AX+FEM |
| Case 4e: 1.25(DL+CL)+1.4(WL+AX)+1.1(TL)+LL | Case 9c: DL+CL+0.25(SL)+0.7(TL)+SM+AX+FEM |
| Case 4f: 1.25(DL+CL)+1.4(WL-AX)+1.1(TL)+LL | Case 9d: DL+CL+0.25(SL)+0.7(TL)+SM-AX+FEM |
| Case 5a: 0.9(DL)+1.4(WL+AX) | Case 9e: DL+CL+LL+1.1(TL)+SM+AX+FEM |
| Case 5b: 0.9(DL)+1.4(WL-AX) | Case 9f: DL+CL+LL+1.1(TL)+SM-AX+FEM |
| Case 5c: 0.9(DL)+1.4(WL+AX+IP) | Case 10a: DL+SM+AX |
| Case 5d: 0.9(DL)+1.4(WL-AX+IP) | Case 10b: DL+SM-AX |
| Case 5e: DL+SM+AX | Case 10c: DL+CL+SM+AX |
| Case 5f: DL+SM-AX | Case 10d: DL+CL+SM-AX |

STRESS ANALYSIS - PAGE 1



NEW MILLENNIUM
BUILDING SYSTEMS

Job Number: 8010-0704	Job Name: 10-123 BARRHAVEN FIRE STATION - SHOPORDERS	Date Run: 11/19/2010 4:21:52 PM
Location: OTTAWA, ON	Joist Description: Deep Long Span 58DLH515/235	Mark: TJ47

Geometry

Base Length: 67-7 3/8	Working Length: 67-3 3/8	Joist Depth: 58.00	Effective Depth: 56.04	BC Panel Length: 6 @ 9-4	Shape: Parallel Chords
---------------------------------	------------------------------------	------------------------------	----------------------------------	------------------------------------	----------------------------------

Variable	Left End	Right End
BC Panel	5-9 5/8	5-9 5/8
TC Panel	5-2 3/4	5-2 3/4
First Half	4-8	4-8 1/8
First Diag.	10-5 5/8	10-5 3/4
Depth	58.00	58.00

Deflection Case 2a: LL (Max Deflection: -1.57 in-Y, -0.28 in-X)

Loads, *** All loads are factored ***

Load Type	Category	Load1	Load2	Position	Direction	Loc/Begin	Sp/End
Uniform (plf)	DL	162.50	162.50	TC	+	0-0	67-7 3/8
Uniform (plf)	LL	352.50	352.50	TC	+	0-0	67-7 3/8
Net Uplift (plf)	WL	250.00	250.00	TC	-	0-0	67-7 3/8
Conc Load (lbs)	LL	3,375.00	0.00	TC	+	7-4	7-4
Conc Load (lbs)	LL	3,375.00	0.00	TC	+	22-10	22-10
Conc Load (lbs)	LL	3,375.00	0.00	TC	+	25-8 1/2	25-8 1/2
Conc anywhere (lbs)	TL	315.00	0.00	BC	+	33-9 3/4	0-0
Conc anywhere (lbs)	TL	315.00	0.00	TC	+	33-9 3/4	0-0
Conc Load (lbs)	LL	3,375.00	0.00	TC	+	41-2 1/4	41-2 1/4
Conc Load (lbs)	LL	3,375.00	0.00	TC	+	44-1	44-1
Uniform (plf)	LL	0.00	500.00	TC	+	52-6 1/2	68-3
Conc Load (lbs)	LL	3,375.00	0.00	TC	+	59-6 7/8	59-6 7/8

Stress Analysis Summary

Int. Panel TC: 56.00	Max Panel BC: 112.13	Reaction LE: 28,451.96	Reaction RE: 31,445.64	Minimum Shear: 7,861.41	Max TC Comp.: 107,406.28	Max BC Tension: 106,270.30
--------------------------------	--------------------------------	----------------------------------	----------------------------------	-----------------------------------	------------------------------------	--------------------------------------

Member	TC Tension	TC Compression	BC Tension	BC Compression	Web Tension	Web Comp.	Web Length	PP Dist.
W2	9,568.52	34,599.07	0.00	0.00	45,424.46	12,426.81	87.83	0-2
V1S	9,407.45	33,872.63	0.00	0.00	1,324.05	7,087.76	56.46	5-2 3/4
W3	9,407.45	33,872.63	56,657.56	16,032.38	9,362.02	32,504.35	79.22	5-9 5/8
W4	21,379.81	74,237.14	56,657.56	16,032.38	26,116.95	7,568.72	79.22	10-5 5/8
W5	21,379.81	74,237.14	89,324.21	25,538.64	5,887.20	22,596.76	79.22	15-1 5/8
W6	28,508.84	101,324.48	89,324.21	25,538.64	17,526.98	4,205.68	79.22	19-9 5/8
V3	28,508.84	101,324.48	89,324.21	25,538.64	1,189.42	8,241.12	56.04	24-5 5/8
W7	28,508.84	101,324.48	106,270.30	30,290.44	3,030.40	11,113.96	79.22	24-5 5/8
W8	30,883.42	107,406.28	106,270.30	30,290.44	11,113.96	3,030.40	79.22	29-1 5/8
V4	30,883.42	107,406.28	106,270.30	30,290.44	1,189.42	3,570.36	56.04	33-9 5/8

* Symmetrical Joist

Standard Verticals

Member	Position	Max Tension	Max Comp.	Length
V2	Interior	1,189.42	8,241.12	56.04

STRESS ANALYSIS - PAGE 2



NEW MILLENNIUM
BUILDING SYSTEMS

Job Number: 8010-0704	Job Name: 10-123 BARRHAVEN FIRE STATION - SHOPORDERS	Date Run: 11/19/2010 4:21:52 PM
Location: OTTAWA, ON	Joist Description: Deep Long Span 58DLH515/235	Mark: TJ47

Chord Properties

Chord	Area	Rx	Rz	Ryy	Y	Ix	Q	Material
TC	1.9266	1.0861	0.6914	1.8874	0.9811	2.2726	0.9552	37 = 3 1/2 x 3 1/2 x .287
BC	1.9266	1.0861	0.6914	1.8874	0.9811	2.2726	0.9552	37 = 3 1/2 x 3 1/2 x .287

Axial and Bending Analysis

K: 0.75	Fy: 50,000.00	Fb: 45,000.00	Mom of Inertia: 6,054.62	LL 300: 891.22	TL 406: 658.54	Max Bridg TC: 26-8 7/8	Max Bridg BC: 26-2 3/8
-------------------	-------------------------	-------------------------	------------------------------------	--------------------------	--------------------------	----------------------------------	----------------------------------

Top Chord Check	End Panel LE	First Panel LE	Interior Panel	First Panel RE	End Panel RE	
Length	60.75	62.88	56.00	63.00	60.75	Gap Between Chords: 1.1250
Bending Load	499.74	499.74	499.74	743.13	915.25	Min Weld Len 2X: 0.7715
Axial Load	32,387.48	31,814.24	107,406.28	33,872.63	34,599.07	Max Load Fillers TC: 144,815.50
fa	8,405.21	8,256.44	27,874.12	8,790.64	8,979.16	Max Load no Fillers TC: 125,598.63
Maximum K L/r	87.87	90.94	60.75	91.12	87.87	TC OAL/Ryy: 427.7740
Fcr	27,852.60	26,803.80	36,907.31	26,742.25	27,852.60	BC Stress: 29,389.69
Fa	25,067.34	24,123.42	33,216.58	24,068.02	25,067.34	BC L/Rz: 162.1774
F'e	91,479.41	85,400.40	191,389.14	85,061.84	91,479.41	TC Shear Stress: 15,123.81
Cm	0.9694	0.9678	0.9353	0.9656	0.9673	BC Shear Stress: 15,123.81
Panel Point Moment	19266.27	18598.72	12516.55	26905.74	33425.78	
Mid Panel Moment	13746.11	7778.89	6819.73	10966.47	23424.33	
Panel Point fb	10677.35	10307.39	6936.66	14911.13	18524.53	
Mid Panel fb	2967.17	1679.11	1472.08	2367.17	5056.27	
Fillers	0	0	0	0	0	
Panel Point Stress	19,082.56	18,563.84	34,810.78	23,701.77	27,503.70	
Mid Panel Stress	0.4016	0.3799	0.8731	0.4186	0.4717	

Web Design

Member	Web Tension	Allow Tension	Web Comp	Allow Comp	Weld	Qty	Material
W2	45,424.46	47,129.38	12,426.81	14,607.50	13.16 x 0.155	2	15 = 1 3/4 x 1 3/4 x .155
W3	9,362.02	74,296.57	32,504.35	35,273.55	7.78 x 0.188	2	20 = 2 x 2 x .216
W4	26,116.95	37,148.29	7,568.72	8,135.56	6.25 x 0.188	1	20 = 2 x 2 x .216
W5	5,887.20	56,851.68	22,596.76	26,895.34	6.22 x 0.163	2	17 = 2 x 2 x .163
W6	17,526.98	36,889.49	4,205.68	4,431.59	4.20 x 0.188	1	C38 = 1.125 x 1.844 x .200
W7	3,030.40	40,084.63	11,113.96	11,134.00	3.22 x 0.155	2	12 = 1 1/2 x 1 1/2 x .155
W8	11,113.96	25,317.00	3,030.40	3,166.32	3.06 x 0.163	1	C32 = 1.125 x 1.479 x .163
V1	1,324.05	36,889.49	7,087.76	7,867.16	2.00 x 0.188	1	C38 = 1.125 x 1.844 x .200
V2	1,189.42	16,459.83	8,241.12	3,868.57	2.00 x 0.134	1	C22 = 1.125 x 1.086 x .134

* Symmetrical Joist

STRESS ANALYSIS - PAGE 3



NEW MILLENNIUM
BUILDING SYSTEMS

Job Number: 8010-0704	Job Name: 10-123 BARRHAVEN FIRE STATION - SHOPORDERS	Date Run: 11/19/2010 4:21:52 PM
Location: OTTAWA, ON	Joist Description: Deep Long Span 58DLH515/235	Mark: TJ47

TCX Design

TCX Left		TCX Right	
TCX Length	0-0 1/2	TCX Length	0-0
TCX Type	R	TCX Type	R
TCX Depth	7	TCX Depth	7
BPL Length	0-6	BPL Length	0-6
Clear Bearing	0-9 1/4	Clear Bearing	0-6 5/8
BPL Material: 69L = 2 x 3 x .250		BPL Material: 69L = 2 x 3 x .250	

Total Load	515.00	Total Load	515.00
Reqd TL Def L/80	0.01	Reqd TL Def L/80	0.00
Live Load	352.50	Live Load	352.50
Reqd LL Def L/120	0.00	Reqd LL Def L/120	0.00
Section Modulus	1.8044	Section Modulus	0.0000
Reqd SM	0.0001	Reqd SM	0.0000
Mom of Inertia	4.5451	Mom of Inertia	0.0000
Reqd MI	0.0000	Reqd MI	0.0000

Seat Type: T-Plate

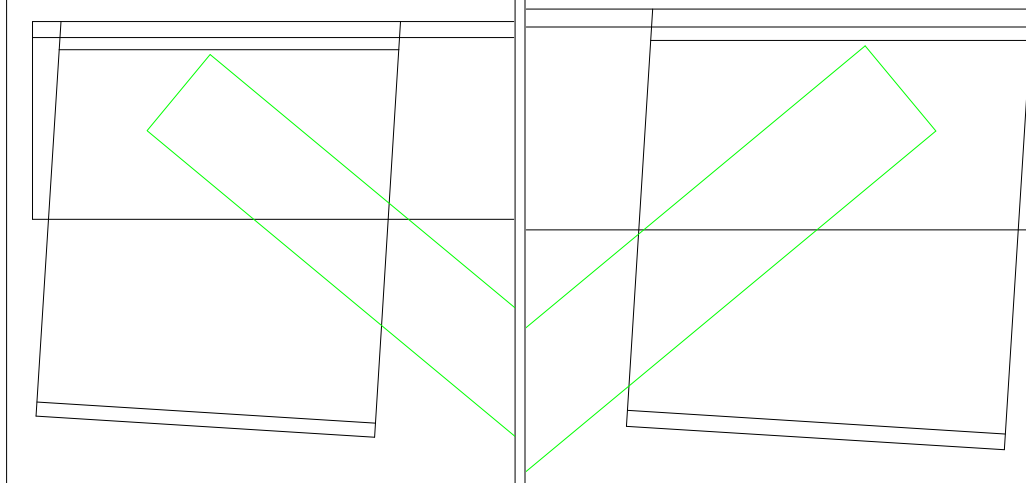

LSD Design

- | | |
|--|--|
| Case 1a: DL | Case 6a: 1.25(DL)+0.5(CL+SL)+1.4(WL+AX)+0.8(TL) |
| Case 1b: 1.4(DL) | Case 6b: 1.25(DL)+0.5(CL+SL)+1.4(WL-AX)+0.8(TL) |
| Case 2a: LL | Case 6c: 1.25(DL)+0.5(CL+SL)+1.4(WL+AX+IP)+0.8(TL) |
| Case 2b: SL | Case 6d: 1.25(DL)+0.5(CL+SL)+1.4(WL-AX+IP)+0.8(TL) |
| Case 3a: 1.25(DL+CL)+1.5(TL+LL) | Case 7a: 1.25(DL+CL)+0.4(WL+AX)+1.5(TL+LL) |
| Case 3b: 1.25(DL+CL)+1.5(TL+SL) | Case 7b: 1.25(DL+CL)+0.4(WL-AX)+1.5(TL+LL) |
| Case 3c: 1.25(DL+CL)+1.5(TL+LL+FEM) | Case 7c: 1.25(DL+CL)+0.4(WL+AX+IP)+1.5(TL+LL) |
| Case 3d: 1.25(DL+CL)+1.5(TL+SL+FEM) | Case 7d: 1.25(DL+CL)+0.4(WL-AX+IP)+1.5(TL+LL) |
| Case 3e: DL+CL+TL+LL | Case 8a: 1.25(DL+CL)+0.4(WL+AX)+1.5(TL+SL) |
| Case 3f: DL+CL+TL+SL | Case 8b: 1.25(DL+CL)+0.4(WL-AX)+1.5(TL+SL) |
| Case 4a: 1.25(DL)+0.5(CL+LL)+1.4(WL+AX)+0.8(TL) | Case 8c: 1.25(DL+CL)+0.4(WL+AX+IP)+1.5(TL+SL) |
| Case 4b: 1.25(DL)+0.5(CL+LL)+1.4(WL-AX)+0.8(TL) | Case 8d: 1.25(DL+CL)+0.4(WL-AX+IP)+1.5(TL+SL) |
| Case 4c: 1.25(DL)+0.5(CL+LL)+1.4(WL+AX+IP)+0.8(TL) | Case 9a: DL+CL+0.5(LL)+0.7(TL)+SM+AX+FEM |
| Case 4d: 1.25(DL)+0.5(CL+LL)+1.4(WL-AX+IP)+0.8(TL) | Case 9b: DL+CL+0.5(LL)+0.7(TL)+SM-AX+FEM |
| Case 4e: 1.25(DL+CL)+1.4(WL+AX)+1.1(TL)+LL | Case 9c: DL+CL+0.25(SL)+0.7(TL)+SM+AX+FEM |
| Case 4f: 1.25(DL+CL)+1.4(WL-AX)+1.1(TL)+LL | Case 9d: DL+CL+0.25(SL)+0.7(TL)+SM-AX+FEM |
| Case 5a: 0.9(DL)+1.4(WL+AX) | Case 9e: DL+CL+LL+1.1(TL)+SM+AX+FEM |
| Case 5b: 0.9(DL)+1.4(WL-AX) | Case 9f: DL+CL+LL+1.1(TL)+SM-AX+FEM |
| Case 5c: 0.9(DL)+1.4(WL+AX+IP) | Case 10a: DL+SM+AX |
| Case 5d: 0.9(DL)+1.4(WL-AX+IP) | Case 10b: DL+SM-AX |
| Case 5e: DL+SM+AX | Case 10c: DL+CL+SM+AX |
| Case 5f: DL+SM-AX | Case 10d: DL+CL+SM-AX |

STRESS ANALYSIS - PAGE 1



NEW MILLENNIUM
BUILDING SYSTEMS

Job Number: 8010-0704	Job Name: 10-123 BARRHAVEN FIRE STATION - SHOPORDERS	Date Run: 11/19/2010 3:57:21 PM
Location: OTTAWA, ON		Joist Description: Short Span Round 12K594/271
		Mark: TJ50

Geometry

Base Length: 14-10 7/8	Working Length: 14-6 7/8	Joist Depth: 12.00	Effective Depth: 11.17	BC Panel Length: 6 @ 1-8	Shape: Parallel Chords
----------------------------------	------------------------------------	------------------------------	----------------------------------	------------------------------------	----------------------------------

Variable	Left End	Right End	Deflection Case 2a: LL (Max Deflection: -0.33 in-Y, -0.06 in-X)
BC Panel	2-5 1/2	2-5 1/2	
TC Panel	1-7 1/2	1-7 1/2	
First Half	0-10	0-10	
First Diag.	3-3 1/2	3-3 1/2	
Depth	12.00	12.00	

Loads, *** All loads are factored ***

Load Type	Category	Load1	Load2	Position	Direction	Loc/Begin	Sp/End
Uniform (plf)	DL	187.50	187.50	TC	+	0-0	14-10 7/8
Uniform (plf)	LL	406.50	406.50	TC	+	0-0	14-10 7/8
Conc Load (lbs)	DL	250.00	0.00	TC	+	<1-1 3/8>	4-10 5/8
Conc anywhere (lbs)	TL	315.00	0.00	BC	+	7-5 1/2	0-0
Net Uplift (plf)	WL	186.00	186.00	TC	-	0-0	14-10 7/8
Conc anywhere (lbs)	TL	315.00	0.00	TC	+	7-5 1/2	0-0
Conc Load (lbs)	DL	250.00	0.00	TC	+	7-10 5/8	13-10 5/8

Stress Analysis Summary

Int. Panel TC: 20.00	Max Panel BC: 20.00	Reaction LE: 5,322.88	Reaction RE: 5,259.13	Minimum Shear: 1,330.72	Max TC Comp.: 20,551.35	Max BC Tension: 20,436.59
--------------------------------	-------------------------------	---------------------------------	---------------------------------	-----------------------------------	-----------------------------------	-------------------------------------

Member	TC Tension	TC Compression	BC Tension	BC Compression	Web Tension	Web Comp.	Web Length	PP Dist.
W2	3,094.92	11,075.49	0.00	0.00	12,998.45	3,839.51	29.68	0-2
V1S	2,826.75	10,244.21	0.00	0.00	678.69	2,611.18	14.99	1-7 1/2
W3	2,826.75	10,244.21	13,440.38	3,684.00	1,597.27	5,143.33	14.99	2-5 1/2
W4	4,255.20	15,740.06	13,440.38	3,684.00	3,814.30	1,169.87	14.99	3-3 1/2
W5	4,255.20	15,740.06	18,039.74	4,826.41	1,194.86	3,726.81	14.99	4-1 1/2
W6	5,111.56	19,238.61	18,039.74	4,826.41	2,397.77	766.12	14.99	4-11 1/2
W7	5,111.56	19,238.61	20,436.59	5,396.72	795.28	2,295.70	14.99	5-9 1/2
W8	5,395.82	20,551.35	20,436.59	5,396.72	1,786.43	1,786.43	14.99	6-7 1/2

* Symmetrical Joist

STRESS ANALYSIS - PAGE 2



NEW MILLENNIUM
BUILDING SYSTEMS

Job Number: 8010-0704	Job Name: 10-123 BARRHAVEN FIRE STATION - SHOPORDERS	Date Run: 11/19/2010 3:57:21 PM
Location: OTTAWA, ON		Joist Description: Short Span Round 12K594/271
		Mark: TJ50

Chord Properties

Chord	Area	Rx	Rz	Ryy	Y	Ix	Q	Material
TC	0.2991	0.4478	0.2552	0.8119	0.4273	0.0600	1.0000	A18 = 1.4375 x .115
BC	0.2613	0.4291	0.2436	0.7853	0.4077	0.0481	0.9946	A16 = 1.3750 x .105

Axial and Bending Analysis

K: 1.00	Fy: 50,000.00	Fb: 45,000.00	Mom of Inertia: 34.88	LL 360: 421.04	LL 240: 631.56	Max Bridg TC: 9-9 3/4	Max Bridg BC: 9-1 3/4
-------------------	-------------------------	-------------------------	---------------------------------	--------------------------	--------------------------	---------------------------------	---------------------------------

Top Chord Check	End Panel LE	First Panel LE	Interior Panel	First Panel RE	End Panel RE	
Length	17.50	20.00	20.00	19.88	17.50	Gap Between Chords: 0.5000
Bending Load	576.41	0.00	0.00	0.00	576.41	Min Weld Len 2X: 0.5000
Axial Load	11,075.49	10,244.21	20,551.35	10,027.35	10,845.50	Max Load Fillers TC: 22,626.30
fa	18,512.38	17,122.91	34,351.02	16,760.45	18,127.96	Max Load no Fillers TC: 16,756.02
Maximum K L/r	68.57	78.36	44.67	77.87	68.57	TC OAL/Ryy: 215.3908
Fcr	35,455.29	31,913.93	43,213.45	32,092.98	35,455.29	BC Stress: 44,973.66
Fa	31,909.76	28,722.54	38,892.11	28,883.68	31,909.76	BC L/Rz: 82.1086
F'e	187,383.92	143,465.81	143,465.81	145,276.09	187,383.92	TC Shear Stress: 23,332.03
Cm	0.9671	0.9602	0.8936	0.9615	0.9678	BC Shear Stress: 26,910.36
Panel Point Moment	2384.14	583.33	583.33	583.33	2371.46	
Mid Panel Moment	1678.24	492.19	492.19	492.19	1683.10	
Panel Point fb	20079.19	4912.82	4912.82	4912.82	19972.41	
Mid Panel fb	5977.67	1753.11	1753.11	1753.11	5994.99	
Fillers	0	0	3	0	0	
Panel Point Stress	38,591.56	22,035.74	39,263.85	21,673.27	38,100.38	
Mid Panel Stress	0.7084	0.6345	0.9254	0.6185	0.6965	

Web Design

Member	Web Tension	Allow Tension	Web Comp	Allow Comp	Weld	Qty	Material
W2	12,998.45	15,184.89	3,839.51	6,554.47	3.03 x 0.192	1	R4 = round 11/16
V1S	678.69	11,294.55	2,611.18	6,435.70	2.00 x 0.177	1	R2 = round 9/16
W3	1,597.27	11,294.55	5,143.33	6,435.70	2.00 x 0.177	1	R2 = round 9/16
W4	3,814.30	8,924.09	1,169.87	4,379.31	2.00 x 0.170	1	R1 = round 1/2
W5	1,194.86	8,924.09	3,726.81	4,379.31	2.00 x 0.170	1	R1 = round 1/2
W6	2,397.77	8,924.09	766.12	4,379.31	2.00 x 0.170	1	R1 = round 1/2
W7	795.28	8,924.09	2,295.70	4,379.31	2.00 x 0.170	1	R1 = round 1/2
W8	1,786.43	8,924.09	1,786.43	4,379.31	2.00 x 0.170	1	R1 = round 1/2

* Symmetrical Joist

STRESS ANALYSIS - PAGE 3



NEW MILLENNIUM
BUILDING SYSTEMS

<i>Job Number:</i> 8010-0704	<i>Job Name:</i> 10-123 BARRHAVEN FIRE STATION - SHOPORDERS	<i>Date Run:</i> 11/19/2010 3:57:21 PM
<i>Location:</i> OTTAWA, ON	<i>Joist Description:</i> Short Span Round 12K594/271	<i>Mark:</i> TJ50

TCX Design

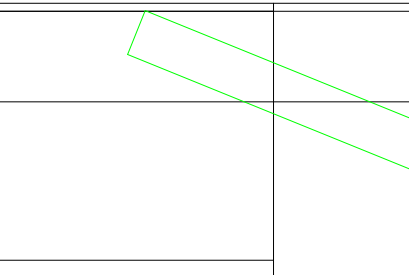
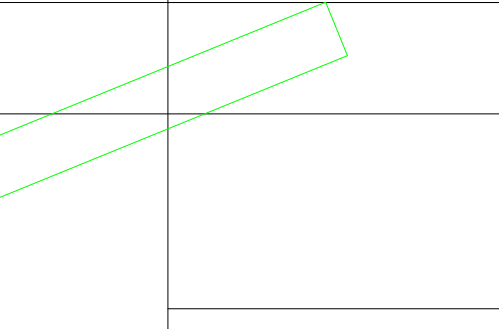
TCX Left		TCX Right	
TCX Length	0-1 3/8	TCX Length	0-0
TCX Type	R	TCX Type	R
TCX Depth	4	TCX Depth	4
BPL Length	0-4	BPL Length	0-4
Clear Bearing	0-9 7/8	Clear Bearing	0-9 7/8
BPL Material: 69L = 2 x 3 x .250		BPL Material: 69L = 2 x 3 x .250	
Total Load	594.00	Total Load	594.00
Reqd TL Def L/80	0.02	Reqd TL Def L/80	0.00
Live Load	406.50	Live Load	406.50
Reqd LL Def L/120	0.01	Reqd LL Def L/120	0.00
Section Modulus	0.1187	Section Modulus	0.0000
Reqd SM	0.0011	Reqd SM	0.0000
Mom of Inertia	0.1200	Mom of Inertia	0.0000
Reqd MI	0.0000	Reqd MI	0.0000
Seat Type: Bird Cage		Seat Type: Bird Cage	
			

LSD Design

- | | |
|--|---|
| <p>Case 1a: DL
 Case 1b: 1.4(DL)
 Case 2a: LL
 Case 2b: SL
 Case 3a: 1.25(DL+CL)+1.5(TL+LL)
 Case 3b: 1.25(DL+CL)+1.5(TL+SL)
 Case 3c: 1.25(DL+CL)+1.5(TL+LL+FEM)
 Case 3d: 1.25(DL+CL)+1.5(TL+SL+FEM)
 Case 3e: DL+CL+TL+LL
 Case 3f: DL+CL+TL+SL
 Case 4a: 1.25(DL)+0.5(CL+LL)+1.4(WL+AX)+0.8(TL)
 Case 4b: 1.25(DL)+0.5(CL+LL)+1.4(WL-AX)+0.8(TL)
 Case 4c: 1.25(DL)+0.5(CL+LL)+1.4(WL+AX+IP)+0.8(TL)
 Case 4d: 1.25(DL)+0.5(CL+LL)+1.4(WL-AX+IP)+0.8(TL)
 Case 4e: 1.25(DL+CL)+1.4(WL+AX)+1.1(TL)+LL
 Case 4f: 1.25(DL+CL)+1.4(WL-AX)+1.1(TL)+LL
 Case 5a: 0.9(DL)+1.4(WL+AX)
 Case 5b: 0.9(DL)+1.4(WL-AX)
 Case 5c: 0.9(DL)+1.4(WL+AX+IP)
 Case 5d: 0.9(DL)+1.4(WL-AX+IP)
 Case 5e: DL+SM+AX
 Case 5f: DL+SM-AX</p> | <p>Case 6a: 1.25(DL)+0.5(CL+SL)+1.4(WL+AX)+0.8(TL)
 Case 6b: 1.25(DL)+0.5(CL+SL)+1.4(WL-AX)+0.8(TL)
 Case 6c: 1.25(DL)+0.5(CL+SL)+1.4(WL+AX+IP)+0.8(TL)
 Case 6d: 1.25(DL)+0.5(CL+SL)+1.4(WL-AX+IP)+0.8(TL)
 Case 7a: 1.25(DL+CL)+0.4(WL+AX)+1.5(TL+LL)
 Case 7b: 1.25(DL+CL)+0.4(WL-AX)+1.5(TL+LL)
 Case 7c: 1.25(DL+CL)+0.4(WL+AX+IP)+1.5(TL+LL)
 Case 7d: 1.25(DL+CL)+0.4(WL-AX+IP)+1.5(TL+LL)
 Case 8a: 1.25(DL+CL)+0.4(WL+AX)+1.5(TL+SL)
 Case 8b: 1.25(DL+CL)+0.4(WL-AX)+1.5(TL+SL)
 Case 8c: 1.25(DL+CL)+0.4(WL+AX+IP)+1.5(TL+SL)
 Case 8d: 1.25(DL+CL)+0.4(WL-AX+IP)+1.5(TL+SL)
 Case 9a: DL+CL+0.5(LL)+0.7(TL)+SM+AX+FEM
 Case 9b: DL+CL+0.5(LL)+0.7(TL)+SM-AX+FEM
 Case 9c: DL+CL+0.25(SL)+0.7(TL)+SM+AX+FEM
 Case 9d: DL+CL+0.25(SL)+0.7(TL)+SM-AX+FEM
 Case 9e: DL+CL+LL+1.1(TL)+SM+AX+FEM
 Case 9f: DL+CL+LL+1.1(TL)+SM-AX+FEM
 Case 10a: DL+SM+AX
 Case 10b: DL+SM-AX
 Case 10c: DL+CL+SM+AX
 Case 10d: DL+CL+SM-AX</p> |
|--|---|